

0001	FIAT - TALBOT - TOYOTA	BENDIX	X	109	39	12,5	4		

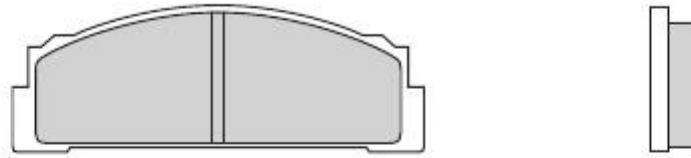

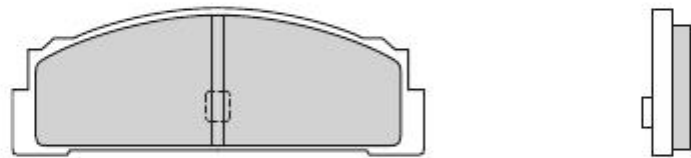

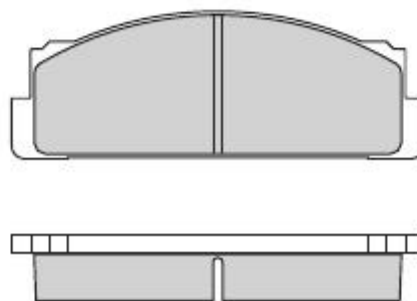





0003	AUTOBIANCHI - FIAT LANCIA - SEAT - TALBOT	BENDIX	X	108,8	39	10	4		
------	--	--------	---	-------	----	----	---	--	--



0004	AUTOBIANCHI - FIAT LANCIA - SEAT - YUGO	BENDIX	X	109	39	17,5	4		
------	--	--------	---	-----	----	------	---	--	--

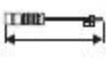

									
0005	ALFA ROMEO - FIAT - JAGUAR PEUGEOT - TALBOT	GIRLING	X	X	80,7	66	15,5	4	

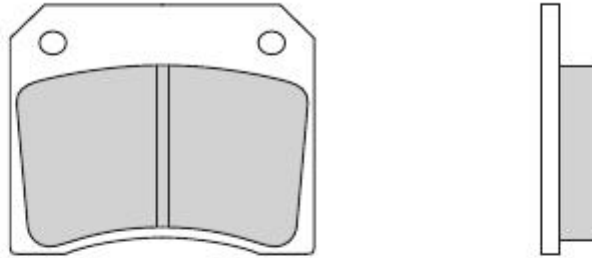



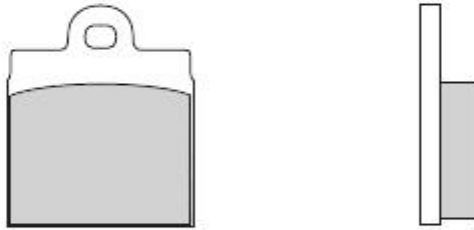



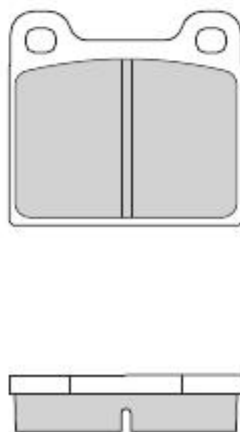

0008	VOLKSWAGEN	ATE	X		49,7	58	15	4	
------	------------	-----	---	--	------	----	----	---	--



0009	ALFA ROMEO - AUDI - BMW - FORD MERCEDES - OPEL - SAAB - TALBOT VAUXHALL - VOLKSWAGEN - VOLVO	ATE	X	X	61,7	56,5	15	4	
------	--	-----	---	---	------	------	----	---	--

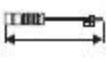

									
0010	ALFA ROMEO - BMW - DAF - SAAB TALBOT - VOLKSWAGEN - VOLVO	ATE	X X	55,8	53	15	4		

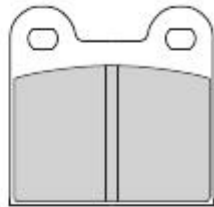



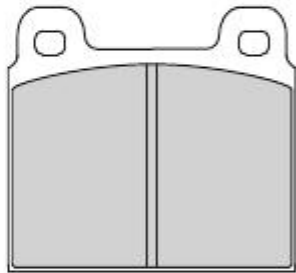



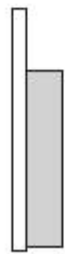

0011	ALFA ROMEO - FORD - MERCEDES OPEL - VAUXHALL	ATE	X	76,8	70,2	15	4		
------	---	-----	---	------	------	----	---	--	--



0012	AUSTIN - INNOCENTI - MORRIS MG - TRIUMPH - VAUXHALL	LOCKHEED	X	74,2	64,4	13,8	4		
------	--	----------	---	------	------	------	---	--	--

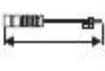

									
0013	HONDA - LANCIA - ROVER	DUNLOP	X	47,2	65,1	17	4		

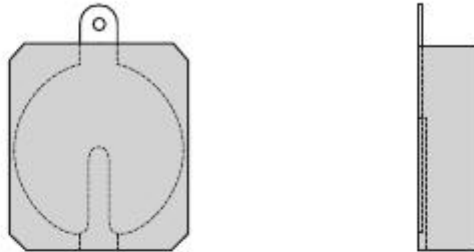



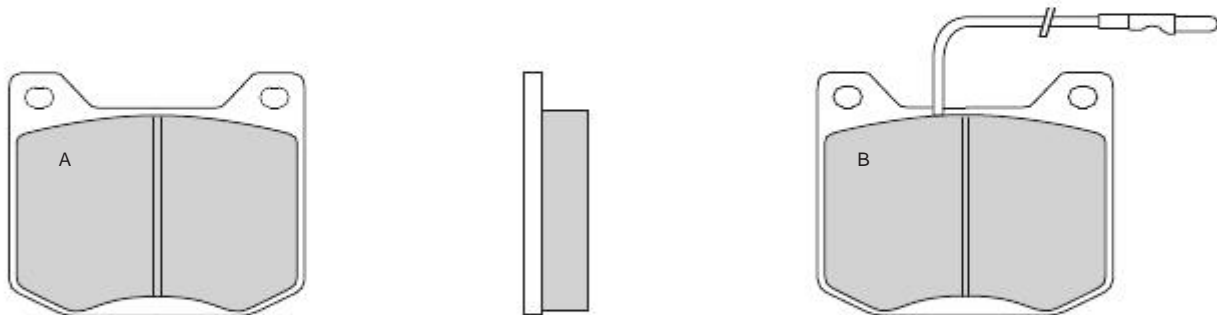



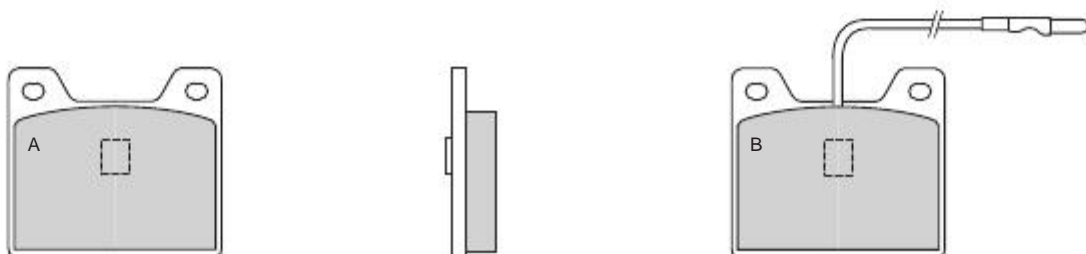

0014	PEUGEOT	GIRLING	X	78,4	64,5	17	2A-2B	2	110
------	---------	---------	---	------	------	----	-------	---	-----



0015	PEUGEOT	GIRLING	X	63,35	55,1	14	2A-2B	2	110
------	---------	---------	---	-------	------	----	-------	---	-----

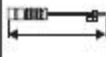

									
<b>0017</b>	<b>CITROEN</b>	<b>GIRLING</b>	<b>X</b>	<b>145,5</b>	<b>83,6</b>	<b>29,8</b>	<b>4</b>	<b>4</b>	<b>110</b>

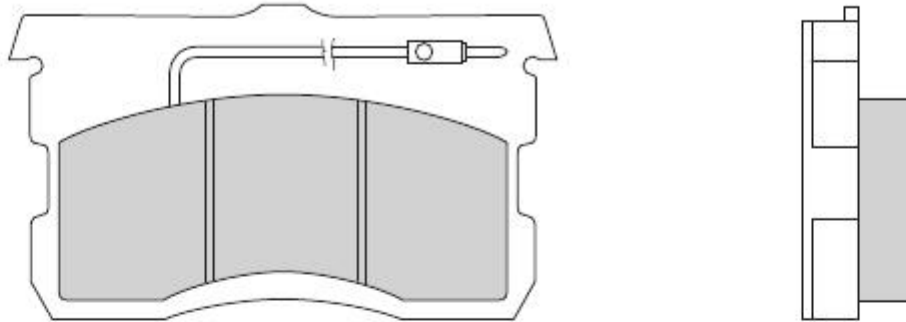



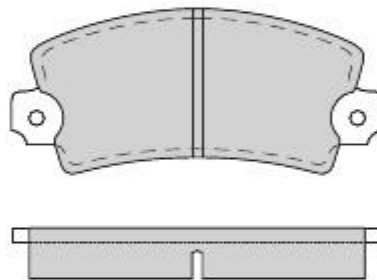



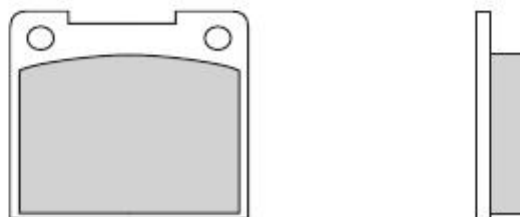

<b>0018</b>	<b>RENAULT</b>	<b>BENDIX</b>	<b>X</b>	<b>108,9</b>	<b>46,2</b>	<b>14</b>	<b>4</b>		
-------------	----------------	---------------	----------	--------------	-------------	-----------	----------	--	--



<b>0019</b>	<b>FORD - INNOCENTI - LANCIA TALBOT - VAUXHALL - VOLVO</b>	<b>GIRLING</b>	<b>X</b>	<b>X</b>	<b>63,4</b>	<b>55,4</b>	<b>14,2</b>	<b>4</b>	
-------------	--	----------------	----------	----------	-------------	-------------	-------------	----------	--

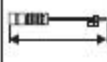

									
<b>0020</b>	FORD - INNOCENTI - ROVER TALBOT - VAUXHALL - VOLVO	GIRLING	X	63,4	63,3	14,4	4		

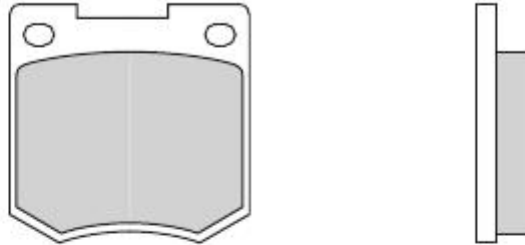



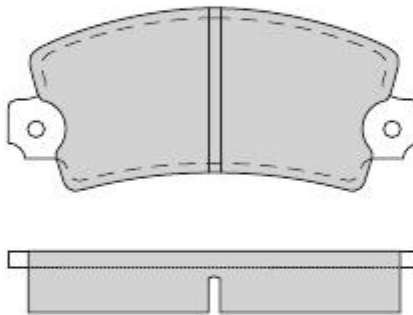



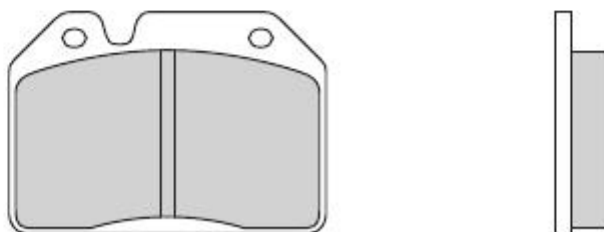

<b>0026</b>	RENAULT	BENDIX	X	108,9	46,2	16	4		
-------------	---------	--------	---	-------	------	----	---	--	--



<b>0027</b>	PEUGEOT	BENDIX	X	83,8	59	15,4	4		
-------------	---------	--------	---	------	----	------	---	--	--

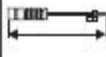

									
<b>0030</b>	SAAB	LOCKHEED	X	96	55,5	10,5-17,5	2A-2B		

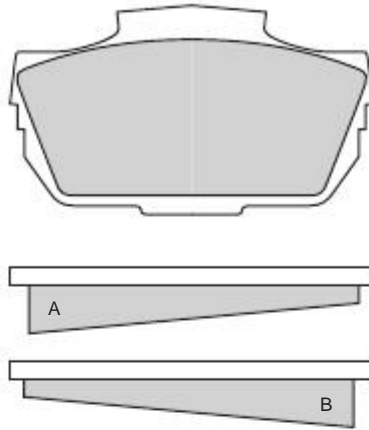



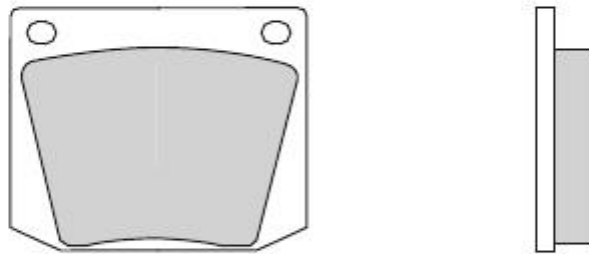



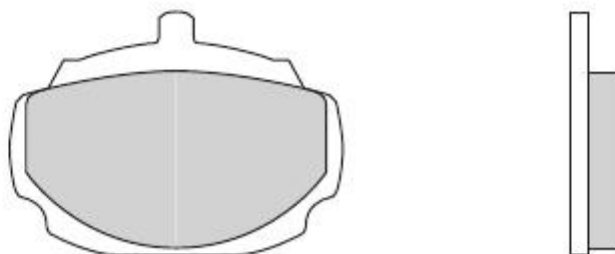



<b>0031</b>	FORD - ROVER TALBOT - VAUXHALL	GIRLING	X	78,4	64,2	15,5	4		
-------------	-----------------------------------	---------	---	------	------	------	---	--	--



<b>0033</b>	AVELING BARFORD - ROVER TALBOT	LOCKHEED	X	88,4	64,5	15	4		
-------------	-----------------------------------	----------	---	------	------	----	---	--	--



									
<b>0035</b>	<b>VOLVO</b>	<b>GIRLING</b>	<b>X</b>	<b>98,3</b>	<b>60,2</b>	<b>16</b>	<b>4</b>		

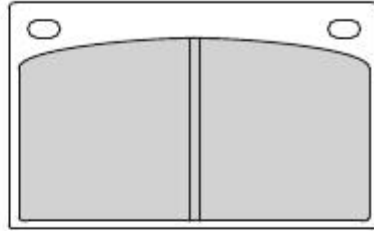



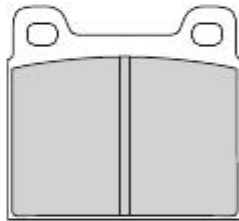





<b>0036</b>	<b>OPEL</b>	<b>ATE</b>	<b>X</b>	<b>61,8</b>	<b>56,5</b>	<b>14</b>	<b>4</b>		
-------------	-------------	------------	----------	-------------	-------------	-----------	----------	--	--



<b>0039</b>	<b>CITROEN</b>	<b>CITROEN</b>	<b>X</b>	<b>89,4</b>	<b>38</b>	<b>12</b>	<b>4</b>		
-------------	----------------	----------------	----------	-------------	-----------	-----------	----------	--	--



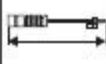

									
<b>0040</b>	INNOCENTI - ROVER	LOCKHEED	X		101	54	11,5-20,5	2A-2B	

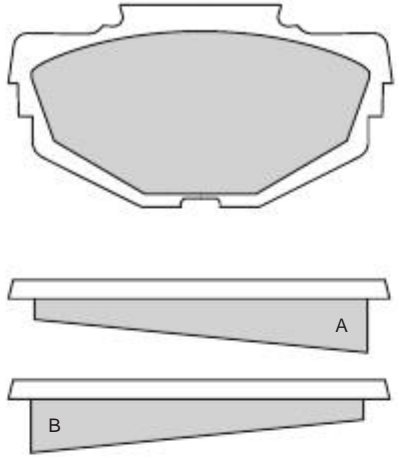



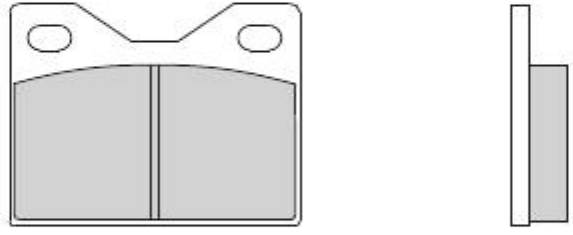



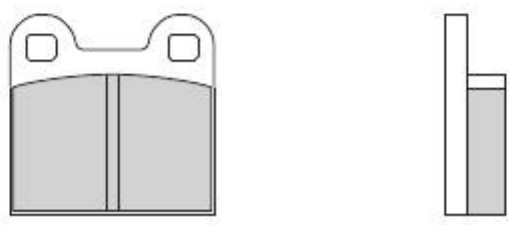



<b>0041</b>	AUDI - BMW - VOLKSWAGEN	ATE	X	X	76,7	58,8	15	4	
-------------	-------------------------	-----	---	---	------	------	----	---	--



<b>0042</b>	OPEL	ATE	X		55,8	53	16	4	
-------------	------	-----	---	--	------	----	----	---	--



									
<b>0043</b>	ALFA ROMEO - BMW	ATE	X	89,9	70,6	15	4		

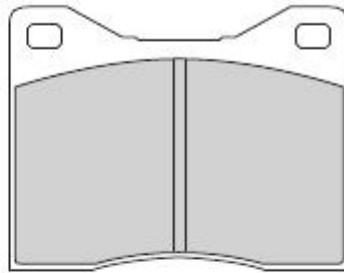



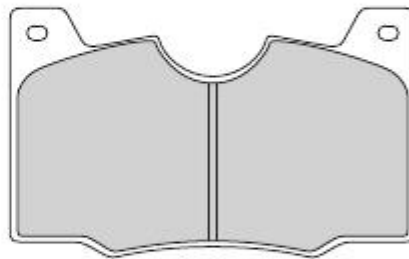



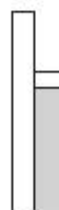
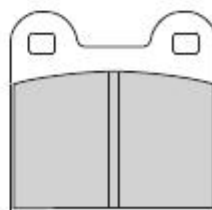



<b>0046</b>	LANCIA	GIRLING	X	107,8	66	15,3	4		
-------------	--------	---------	---	-------	----	------	---	--	--



<b>0047</b>	ALFA ROMEO - SAAB VOLKSWAGEN	ATE	X	55,8	53,1	14	4		
-------------	---------------------------------	-----	---	------	------	----	---	--	--



									
0048	NISSAN	LOCKHEED	X	88,9	54	11,5-18	2A-2B		

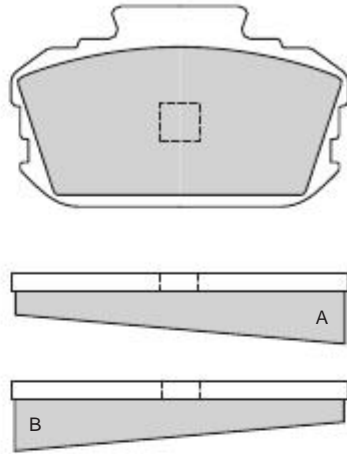



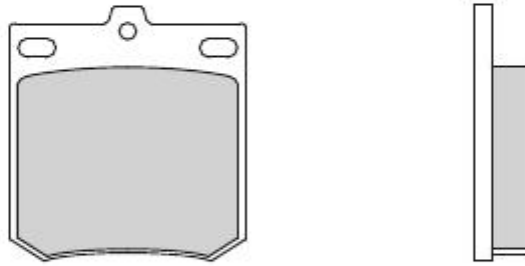



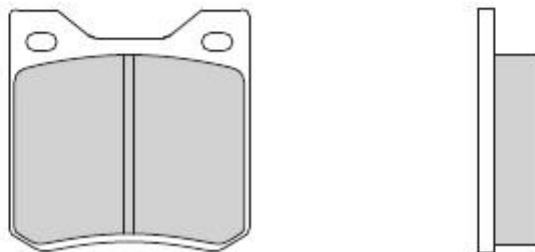









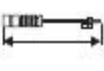
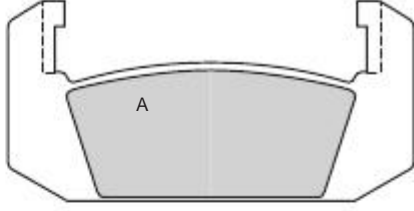
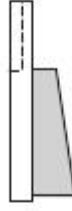
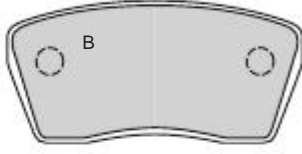
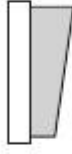
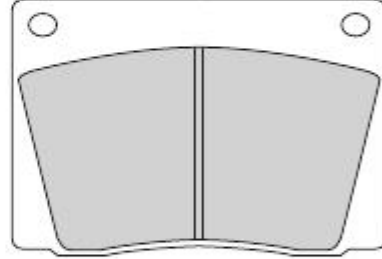
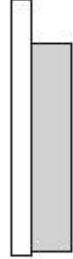
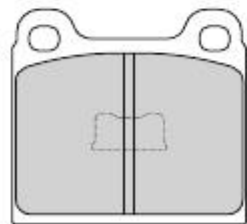



0049	ISUZU - MAZDA MITSUBISHI - TOYOTA	SUMITOMO	X	63,4	68	14,4	4		
------	--------------------------------------	----------	---	------	----	------	---	--	--



0050	PEUGEOT	GIRLING	X	63,4	64,3	15	4		
------	---------	---------	---	------	------	----	---	--	--



									
0051	ROVER	LOCKHEED	X	A 107,3 B 77,5	A 52,7 B 36,5	12,7-17,5	2A-2B		
<div style="display: flex; justify-content: space-around; align-items: center;"> <div style="text-align: center;">  <p>A</p> </div> <div style="text-align: center;">  </div> </div> <div style="display: flex; justify-content: space-around; align-items: center;"> <div style="text-align: center;">  <p>B</p> </div> <div style="text-align: center;">  </div> </div>									
0052	ALFA ROMEO - FIAT MERCEDES - ROVER - VOLVO	GIRLING	X	98,3	68,2	16	4		
<div style="display: flex; justify-content: space-around; align-items: center;"> <div style="text-align: center;">  </div> <div style="text-align: center;">  </div> </div>									
0054	AUDI - VOLKSWAGEN	ATE	X	61,7	56,8	15	4		
<div style="display: flex; justify-content: space-around; align-items: center;"> <div style="text-align: center;">  </div> </div> <div style="display: flex; justify-content: space-around; align-items: center;"> <div style="text-align: center;">  </div> </div>									

									
<b>0058</b>	TALBOT	LOCKHEED	X	88,5	64,7	15	2A-2B		

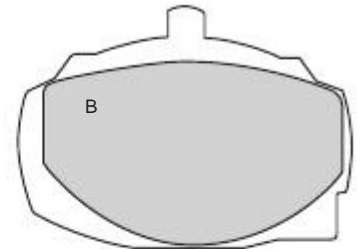
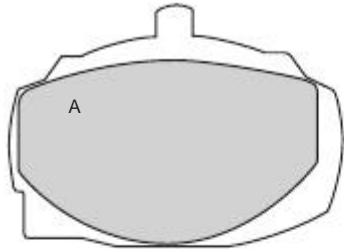



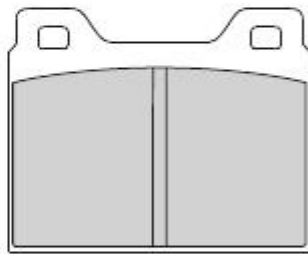



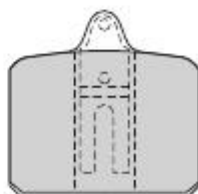

<b>0062</b>	VOLVO	ATE	X	79,7	64,5	15	4		
-------------	-------	-----	---	------	------	----	---	--	--



<b>0064</b>	SKODA	DUNLOP	X	50,7	48,8	15,5	4		
-------------	-------	--------	---	------	------	------	---	--	--

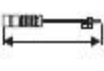

									
<b>0065</b>	LADA	BENDIX	X	84	60,6	16	4		

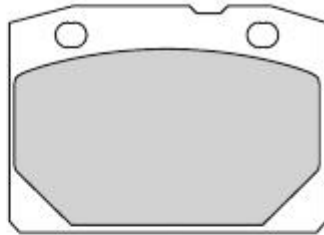



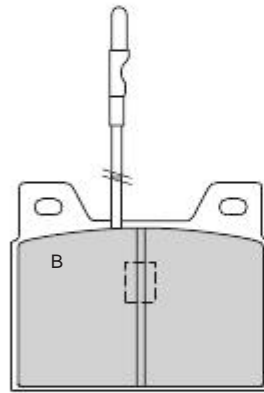
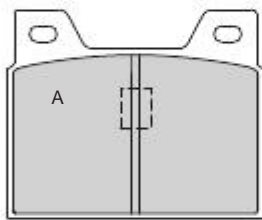







<b>0066</b>	PEUGEOT - TALBOT	GIRLING	X	68,35	55,2	16	2A-2B	2	110
-------------	------------------	---------	---	-------	------	----	-------	---	-----



<b>0067</b>	CITROEN	CITROEN	X	30,4	30,4	7	4		
-------------	---------	---------	---	------	------	---	---	--	--

FRENO A MANO



									
<b>0070</b>	NISSAN	SUMITOMO	X	58	55	14,2	4		

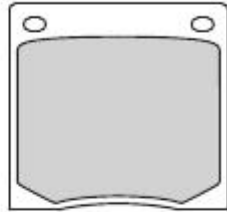



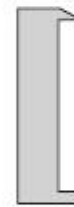
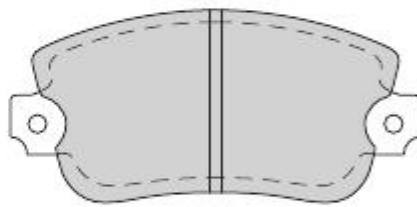





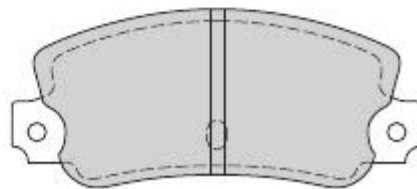

<b>0073</b>	LANCIA	BENDIX	X	108,9	52	17	4		
-------------	--------	--------	---	-------	----	----	---	--	--



F3000

<b>0074</b>	LANCIA	BENDIX	X	109	47	12	4		
-------------	--------	--------	---	-----	----	----	---	--	--



									
<b>0075</b>	ISUZU - MAZDA	SUMITOMO	X	108,8	52,4	14	4		

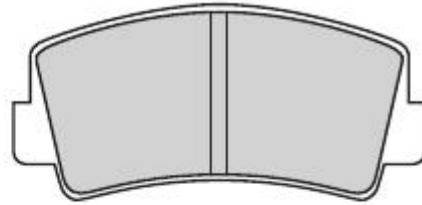



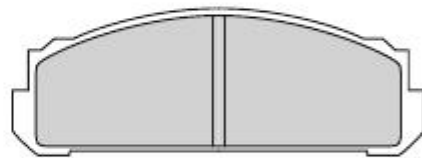



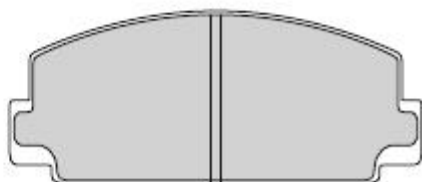



<b>0076</b>	DAIHATSU - NISSAN TOYOTA	BENDIX	X	108,9	39,1	14	4		
-------------	-----------------------------	--------	---	-------	------	----	---	--	--



<b>0077</b>	DAIHATSU - TOYOTA	AKEBONO	X	109	46,3	14	4		
-------------	-------------------	---------	---	-----	------	----	---	--	--





									
<b>0078</b>	NISSAN - TOYOTA	SUMITOMO	X	78,4	68,75	15,4	4		

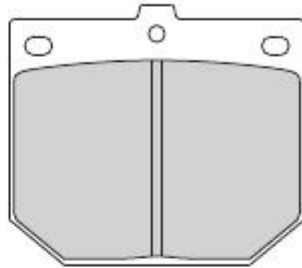



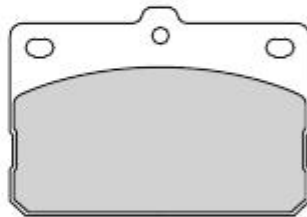







<b>0079</b>	NISSAN - TOYOTA	SUMITOMO	X	78,9	55,6	14,5	4		
-------------	-----------------	----------	---	------	------	------	---	--	--



<b>0081</b>	HONDA	SUMITOMO	X	58	52,5	14,5	4		
-------------	-------	----------	---	----	------	------	---	--	--



									
<b>0082</b>	VOLKSWAGEN	ATE	X	76,8	70,2	19	4		

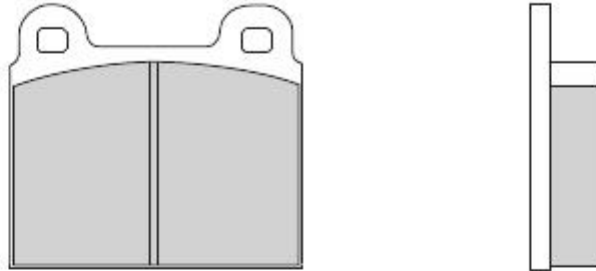



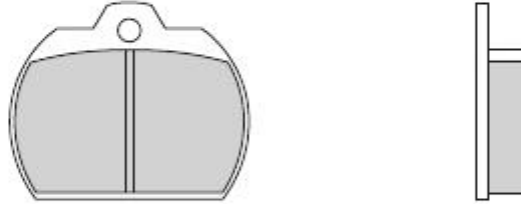



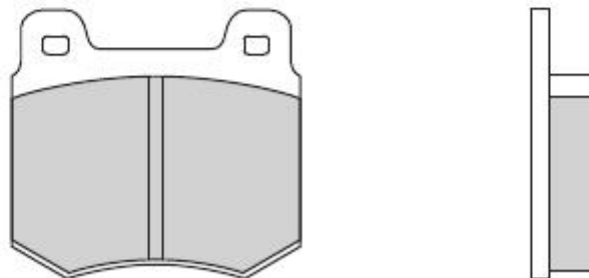



<b>0083</b>	VOLKSWAGEN	GIRLING	X	63,2	51,9	16,4	4		
-------------	------------	---------	---	------	------	------	---	--	--



<b>0084</b>	AUDI - FORD	ATE	X	76,8	72	17	4		
-------------	-------------	-----	---	------	----	----	---	--	--



									
<b>0085</b>	BMW - OPEL - VAUXHALL	ATE	X	76,7	65,5	16,5	4		

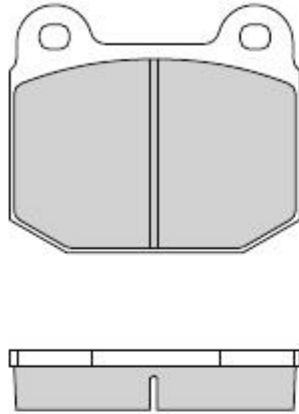



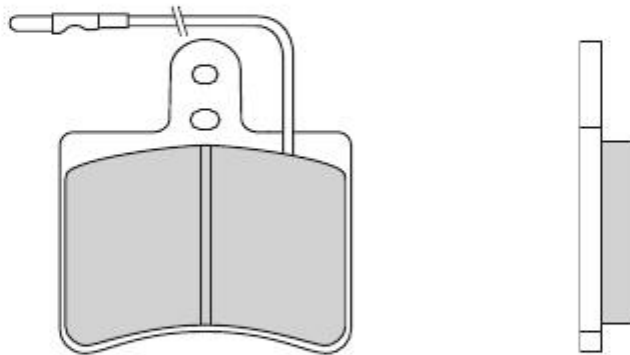





<b>0086</b>	CITROEN	CITROEN	X	77,1	83	16	4	4	110
-------------	---------	---------	---	------	----	----	---	---	-----



<b>0087</b>	CITROEN	CITROEN	X	54,9	60	12	4		
-------------	---------	---------	---	------	----	----	---	--	--

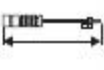

									
<b>0088</b>	ALFA ROMEO	ATE	X	61,6	57	15	2A-2B		

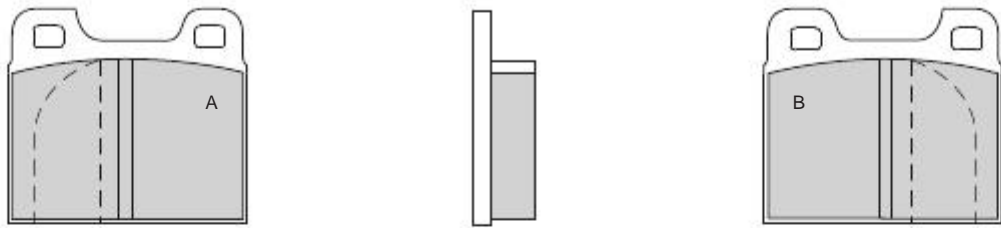



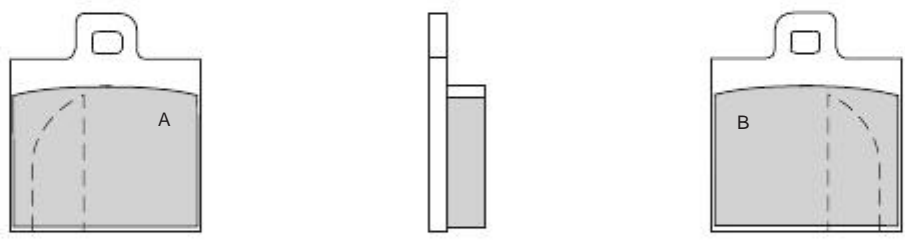



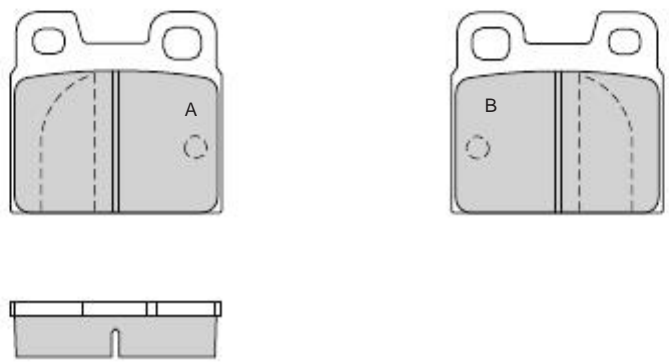

<b>0089</b>	ALFA ROMEO	ATE	X	49,65	58	15	2A-2B		
-------------	------------	-----	---	-------	----	----	-------	--	--



<b>0090</b>	ALFA ROMEO	ATE	X	55,7	53,2	14,8	2A-2B		
-------------	------------	-----	---	------	------	------	-------	--	--

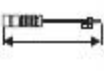

									
<b>0091</b>	AUDI - VOLKSWAGEN	ATE	X	61,7	56,8	18	4		

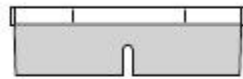
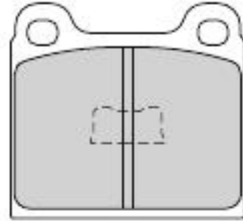



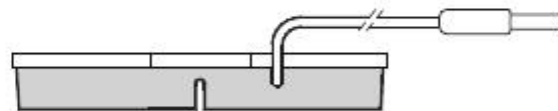
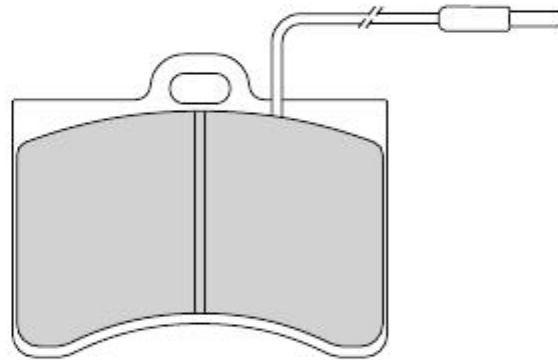



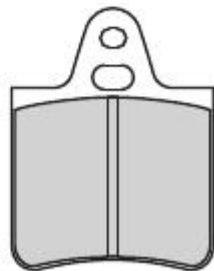

<b>0092</b>	CITROEN	CITROEN	X	99	80,1	15	4	4	180
-------------	---------	---------	---	----	------	----	---	---	-----



<b>0093</b>	CITROEN	CITROEN	X	54	70	16	4		
-------------	---------	---------	---	----	----	----	---	--	--

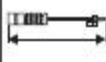

										
0094	CITROEN - FORD	CITROEN	X		114,5	96,7	19,5	4	4	175

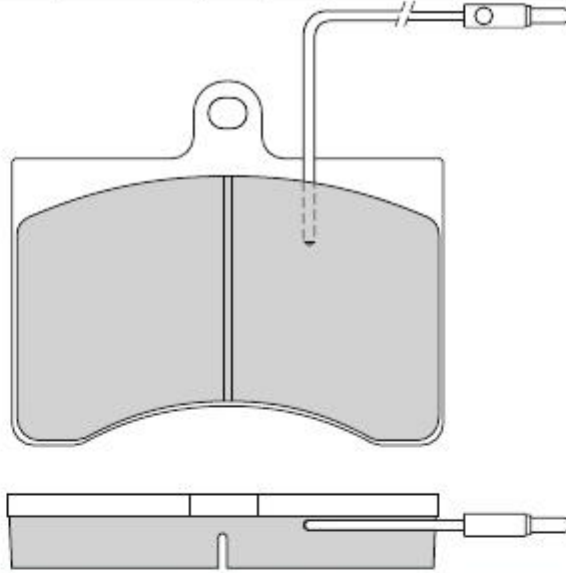



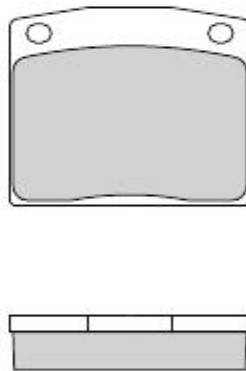



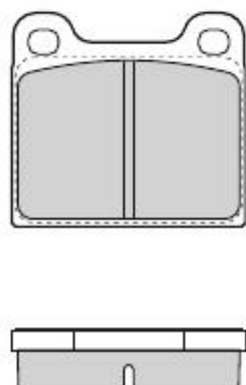

0095	HONDA - NISSAN	SUMITOMO	X		63,5	52,3	14,5	4		
------	----------------	----------	---	--	------	------	------	---	--	--



0096	BMW - MERCEDES OPEL - VOLVO	ATE	X	X	61,7	56,5	15	4		
------	--------------------------------	-----	---	---	------	------	----	---	--	--

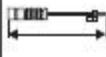

									
<b>0097</b>	MERCEDES	ATE	X	89,7	73,8	15	4		

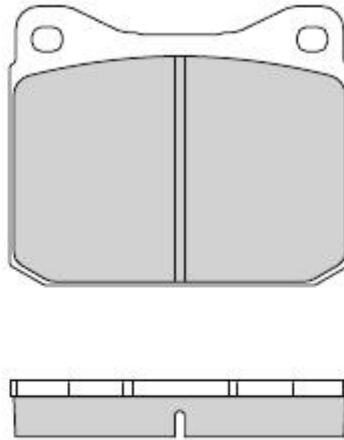



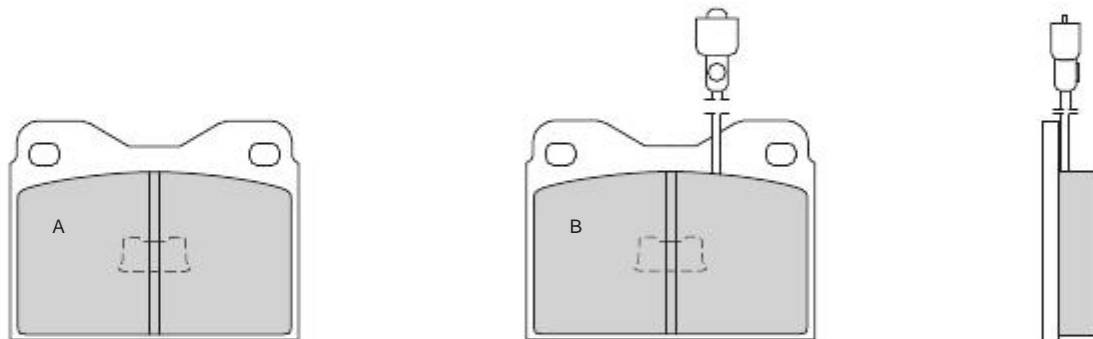



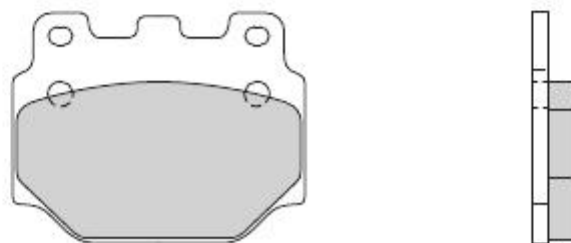

<b>0098</b>	TALBOT	ATE	X	76,8	58,8	15	2A-2B	2	175
-------------	--------	-----	---	------	------	----	-------	---	-----



<b>0099</b>	TOYOTA	SUMITOMO	X	77,7	61,5	13,5	4		
-------------	--------	----------	---	------	------	------	---	--	--

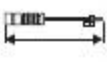

									
0101	FIAT	CITROEN	X	77,1	83	16	4		

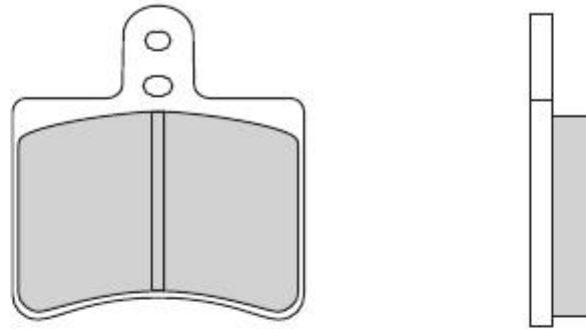



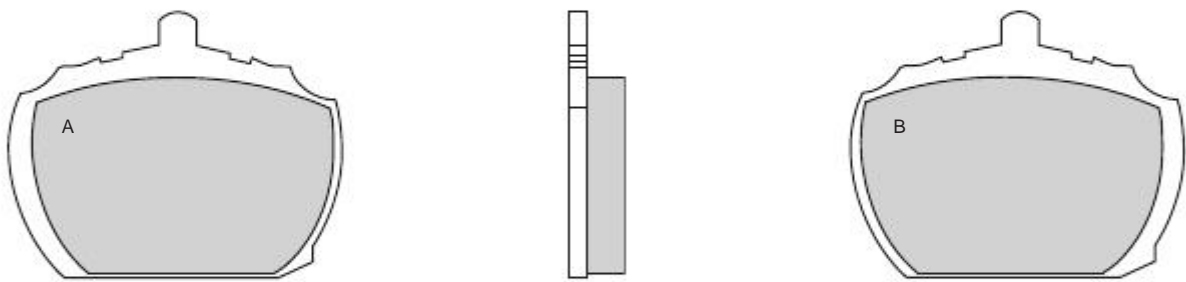



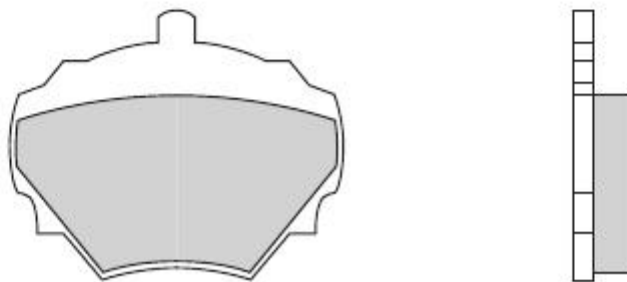



0102	DAF - FORD - LEYLAND DAF ROVER - VAUXHALL	LOCKHEED	X		88,6	70,8	15	2A-2B	
------	--	----------	---	--	------	------	----	-------	--



0103	LAND ROVER - VAUXHALL	LOCKHEED	X	X	88,6	71,6	15	4	
------	-----------------------	----------	---	---	------	------	----	---	--





									
<b>0104</b>	FORD	BENDIX	X	108,4	38	17,5	4		

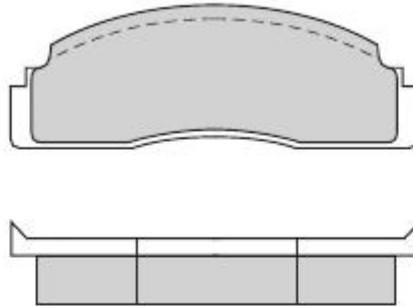



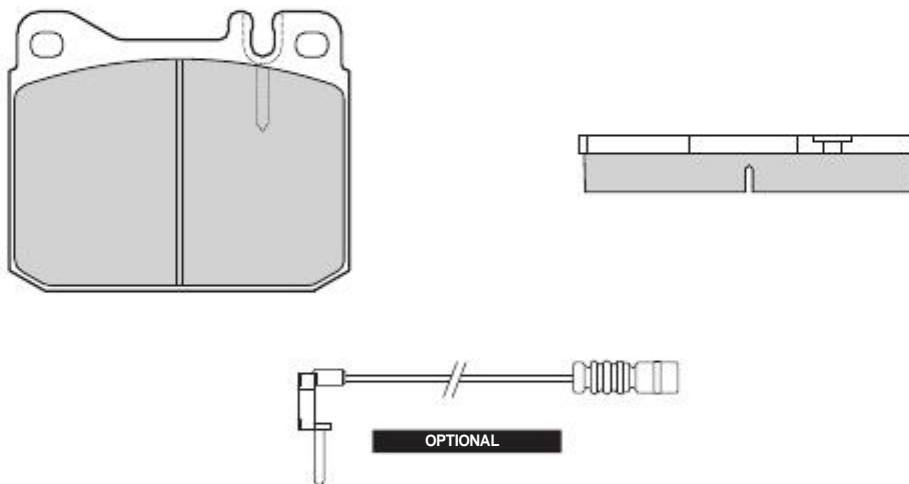



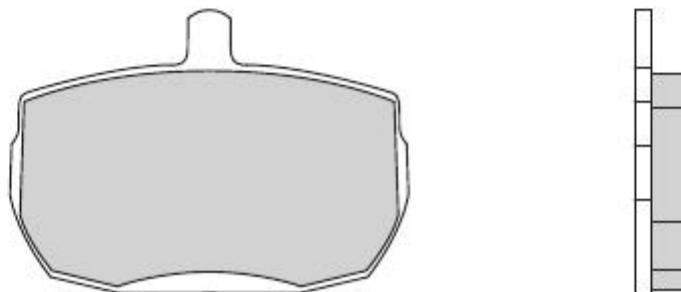



<b>0108</b>	MERCEDES	ATE	X	89,7	73,8	15	4	2	130
-------------	----------	-----	---	------	------	----	---	---	-----



<b>0109</b>	ALFA ROMEO - DAF - FIAT FORD - LAND ROVER	LOCKHEED	X	104,8	74,7	18	4		
-------------	--	----------	---	-------	------	----	---	--	--



									
<b>0111</b>	ROVER - VAUXHALL	LOCKHEED	X	98,5	71	15	4		

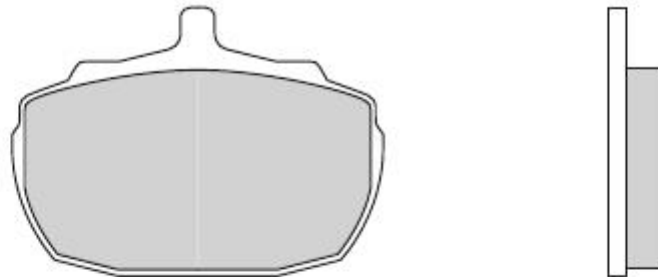



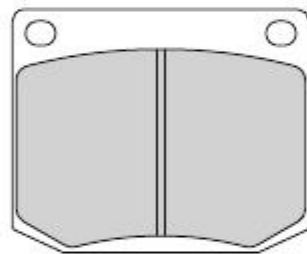



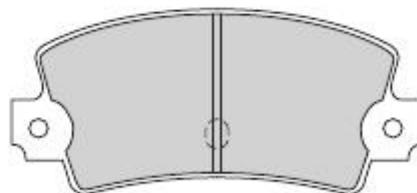

<b>0112</b>	SAAB	GIRLING	X	78,4	64,3	16	4		
-------------	------	---------	---	------	------	----	---	--	--



<b>0114</b>	RENAULT - TALBOT	BENDIX	X	109	49	14	4		
-------------	------------------	--------	---	-----	----	----	---	--	--

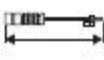

									
<b>0115</b>	HONDA	SUMITOMO	X	63,4	52,3	14,5	4		

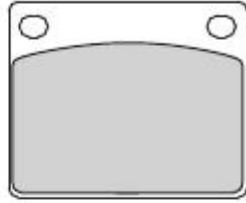



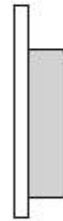
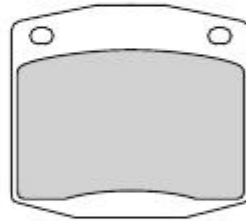



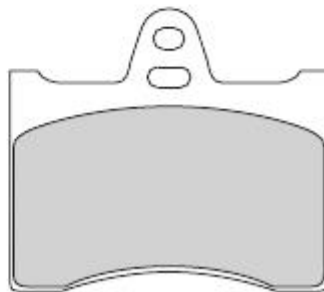



<b>0116</b>	NISSAN	SUMITOMO	X	63,4	56,3	14	4		
-------------	--------	----------	---	------	------	----	---	--	--



<b>0117</b>	CITROEN	CITROEN	X	83	75	16	4		
-------------	---------	---------	---	----	----	----	---	--	--



									
<b>0118</b>	PEUGEOT - TALBOT	ATE	X	89,8	70,5	19	2A-2B	2	175

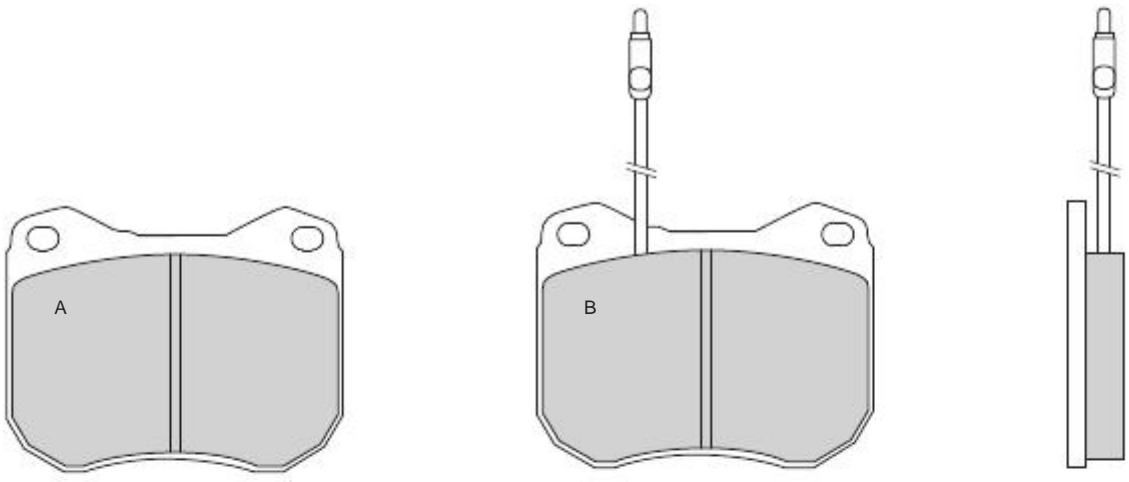

<b>0121</b>	CITROEN	CITROEN	X	42,2	39,4	7,6	4		
-------------	---------	---------	---	------	------	-----	---	--	--









FRENO A MANO



<b>0122</b>	CITROEN	CITROEN	X	41	37,4	9,1	4		
-------------	---------	---------	---	----	------	-----	---	--	--

FRENO A MANO

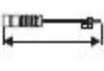

									
<b>0123</b>	MAZDA	AKEBONO	X	108	38,5	14	4		

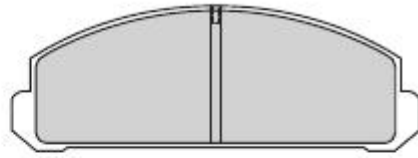



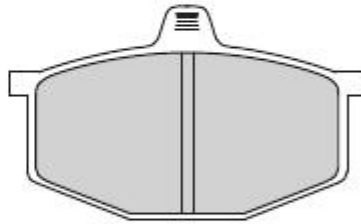



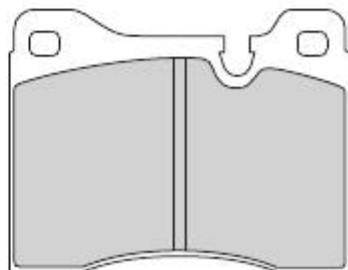

<b>0124</b>	RENAULT	GIRLING	X	93,6	56,5	15,5	4		
-------------	---------	---------	---	------	------	------	---	--	--



<b>0125</b>	BMW	ATE	X	89,8	70,5	18,5	4		
-------------	-----	-----	---	------	------	------	---	--	--

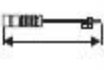

									
<b>0126</b>	SKODA	DUNLOP	X	50,6	48,5	14,7	4		

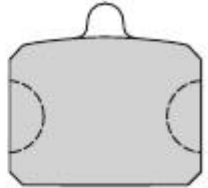



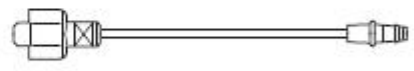
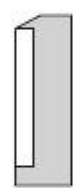
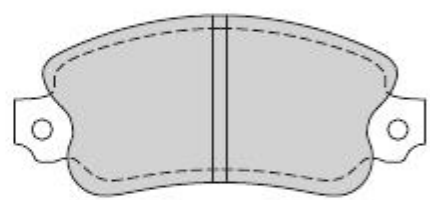



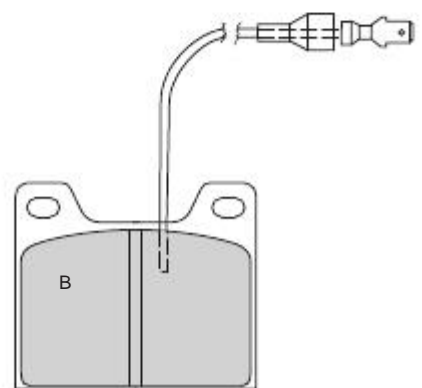
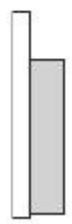
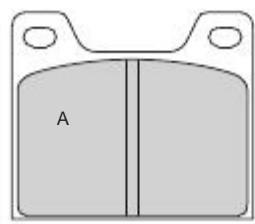

<b>0127</b>	TALBOT	BENDIX	X	108,9	48	15	4	2	110
-------------	--------	--------	---	-------	----	----	---	---	-----



<b>0129</b>	TALBOT	ATE	X	63,4	55,2	14	2A-2B	2	175
-------------	--------	-----	---	------	------	----	-------	---	-----

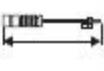

									
<b>0130</b>	CITROEN	CITROEN	X	54,1	65,5	17	4		

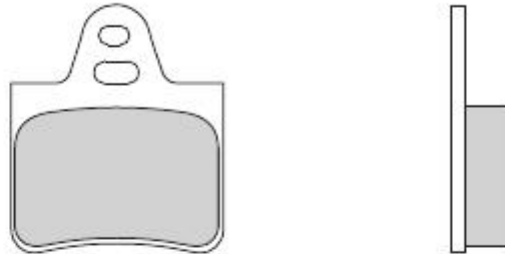



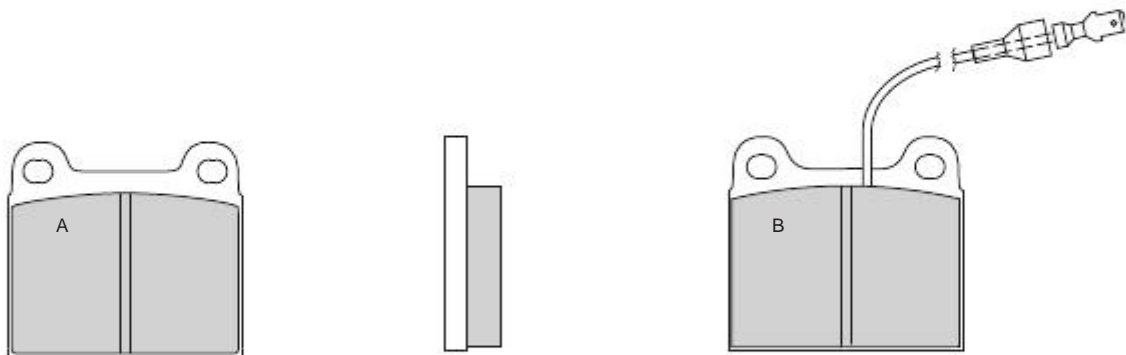



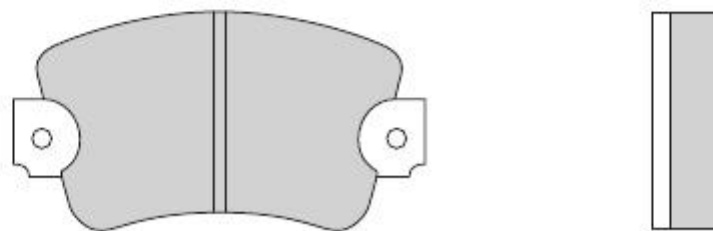



<b>0131</b>	TALBOT	ATE	X	61,7	56,5	15	2A-2B	2	175
-------------	--------	-----	---	------	------	----	-------	---	-----



<b>0132</b>	RENAULT	BENDIX	X	109	58	18,5	4		
-------------	---------	--------	---	-----	----	------	---	--	--



									
<b>0134</b>	PEUGEOT	BENDIX	X	144,1	61	14,6	4		

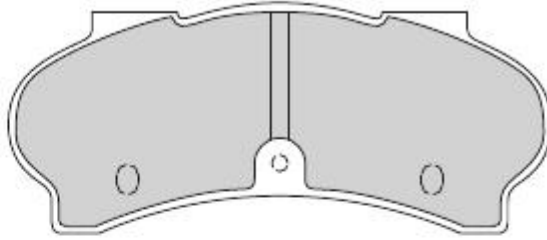

F3000



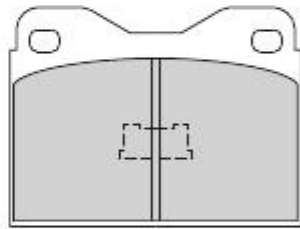



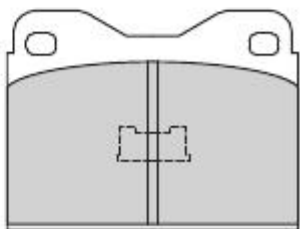

<b>0135</b>	PEUGEOT	ATE	X	76,8	58,8	16,5	4		
-------------	---------	-----	---	------	------	------	---	--	--



<b>0136</b>	AUDI	ATE	X	76,8	58,8	18,5	4		
-------------	------	-----	---	------	------	------	---	--	--



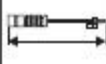

									
<b>0137</b>	SUBARU	AKEBONO	X	108,9	46,2	14,3	4		

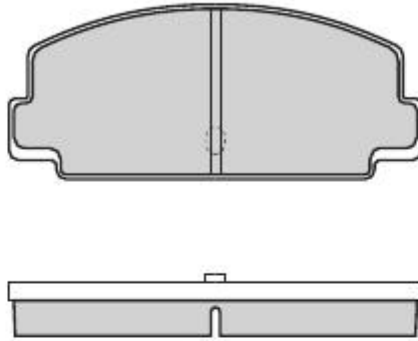



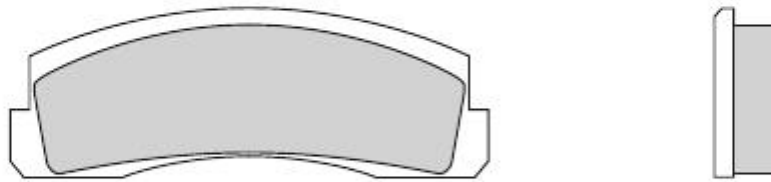



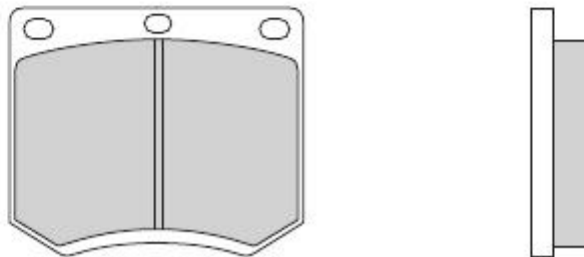

<b>0138</b>	LADA	BENDIX	X	125,7	44,9	16	4		
-------------	------	--------	---	-------	------	----	---	--	--



<b>0139</b>	FORD - HYUNDAI	GIRLING	X	78,4	66	15,3	4		
-------------	----------------	---------	---	------	----	------	---	--	--

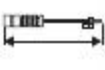

									
<b>0140</b>	SEAT	GIRLING	X	93,3	52	16,5	4		

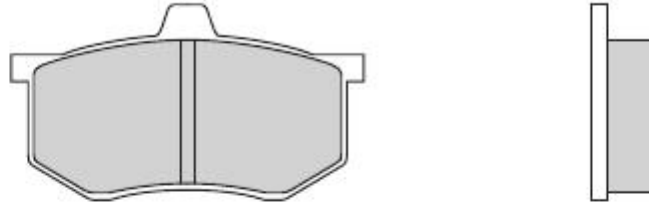



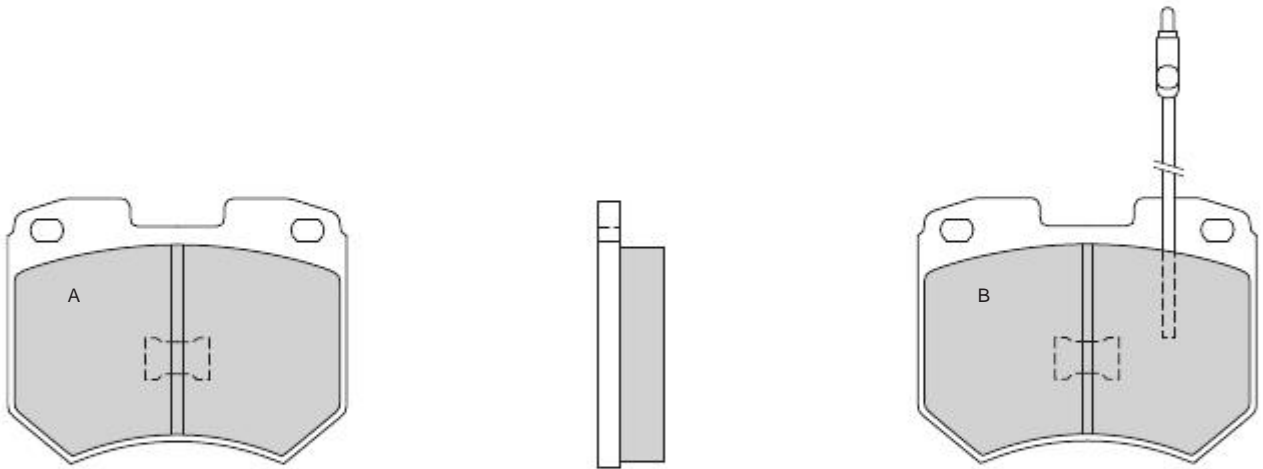



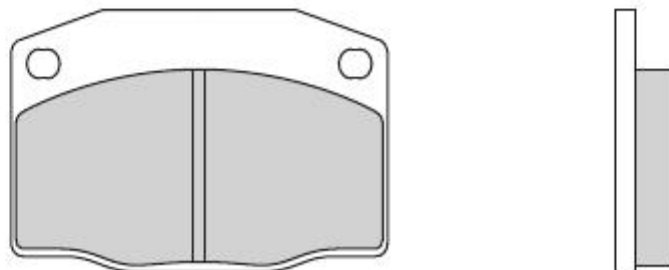

<b>0141</b>	AUDI	ATE	X	89,7	70	19	2A-2B	2	175
-------------	------	-----	---	------	----	----	-------	---	-----



<b>0142</b>	OPEL - VAUXHALL	DELCO	X	100	70	15,5	4		
-------------	-----------------	-------	---	-----	----	------	---	--	--

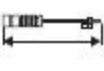

									
<b>0143</b>	AUDI - VOLVO	GIRLING	X	104,5	67	19,5	4		

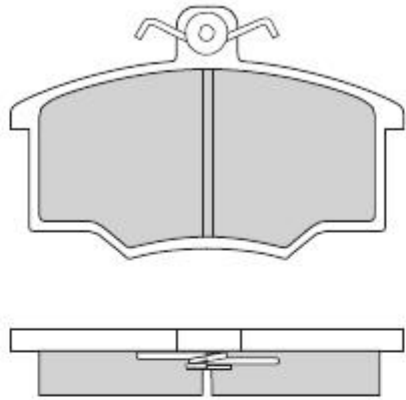



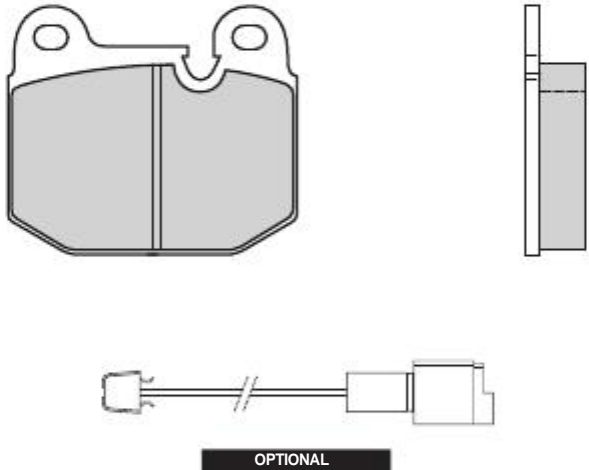



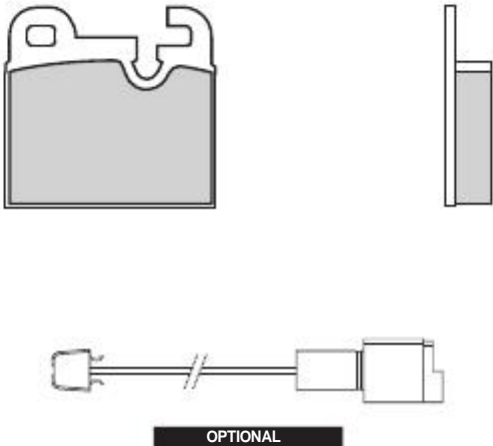

<b>0144</b>	ALFA ROMEO - BMW	ATE	X	76,8	65,8	16,5	4	2	160
-------------	------------------	-----	---	------	------	------	---	---	-----



<b>0145</b>	BMW	ATE	X	55,7	53	15	4	2	160
-------------	-----	-----	---	------	----	----	---	---	-----

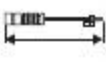

									
0146	ALFA ROMEO - BMW	ATE	X	61,65	57	16,5	4	2	160







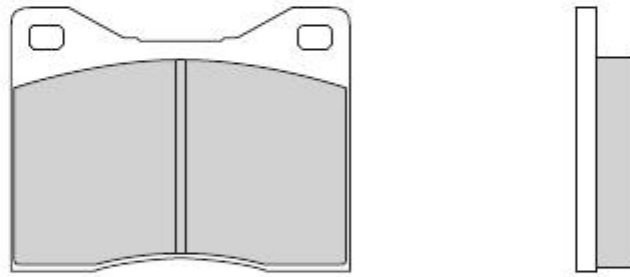



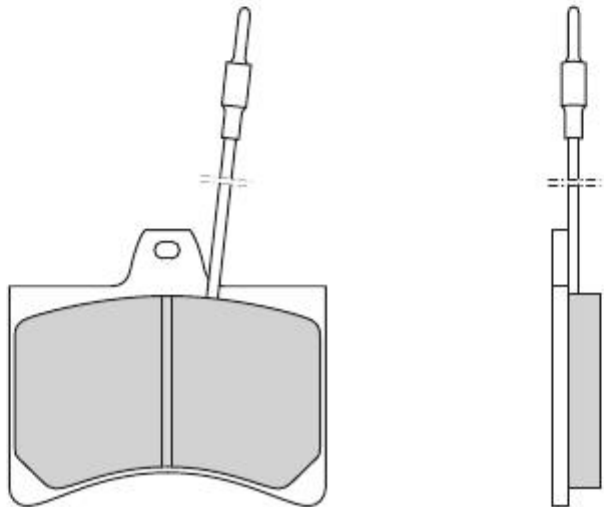

OPTIONAL

0147	BMW	ATE	X	89,9	70,5	19	4		
------	-----	-----	---	------	------	----	---	--	--



0148	CITROEN	CITROEN	X	84	73,5	13	4	4	175
------	---------	---------	---	----	------	----	---	---	-----

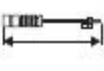

									
<b>0149</b>	MERCEDES	PERROT	X	149	69	18	4		

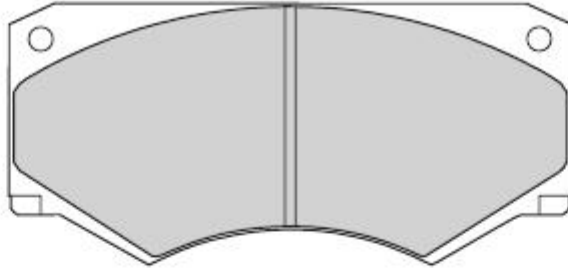



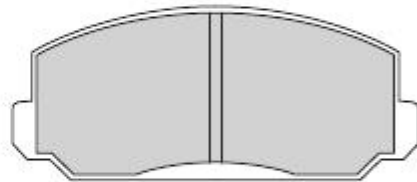



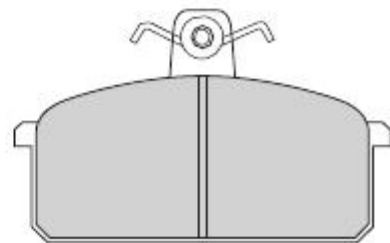



<b>0150</b>	DAIHATSU - HONDA	AKEBONO	X	108,3	46	14,3	4		
-------------	------------------	---------	---	-------	----	------	---	--	--



<b>0151</b>	AUTOBIANCHI - LANCIA SEAT - SUZUKI	GIRLING	X	99,5	61,9	16,5	4		
-------------	---------------------------------------	---------	---	------	------	------	---	--	--



									
<b>0152</b>	MAZDA	SUMITOMO	X	106,2	46,1	15,3	3A-1B		

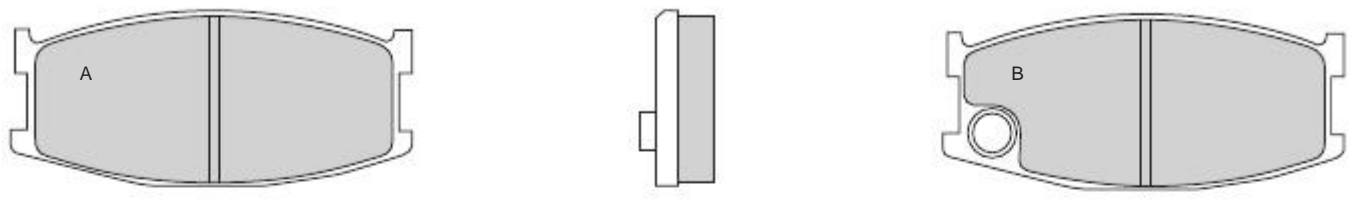



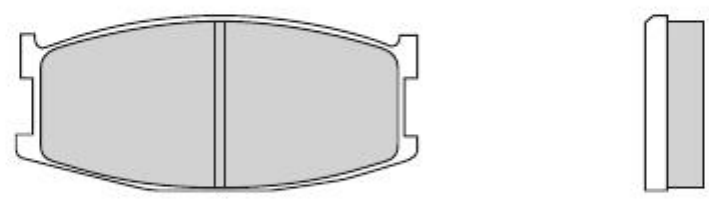



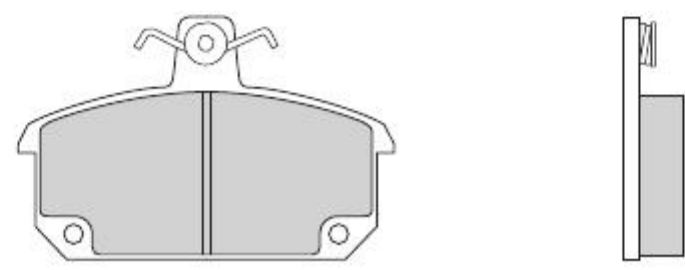



<b>0152-1</b>	MAZDA	SUMITOMO	X	106,2	46,1	15,3	4		
---------------	-------	----------	---	-------	------	------	---	--	--



<b>0153</b>	RENAULT	GIRLING	X	99,5	64,1	16	4		
-------------	---------	---------	---	------	------	----	---	--	--



										
<b>0154</b>	TALBOT	BENDIX	X		84	55	15,5	4	2	110

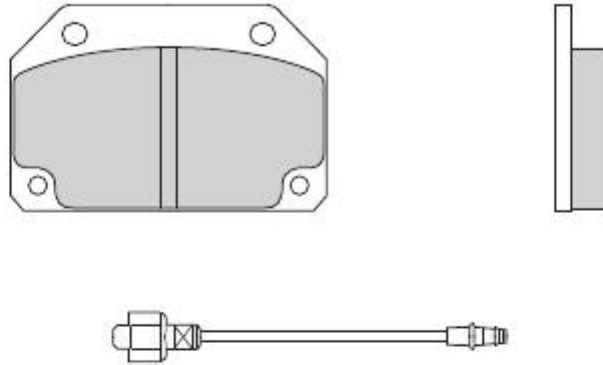



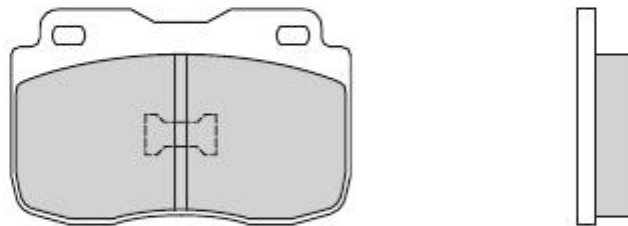





<b>0156</b>	FIAT	ATE	X		89,8	57,5	16	4		
-------------	------	-----	---	--	------	------	----	---	--	--



<b>0157</b>	WARTBURG	LUCAS	X		85,2	57,2	14,5	4		
-------------	----------	-------	---	--	------	------	------	---	--	--

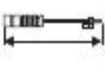

									
<b>0158</b>	FIAT - SEAT - YUGO	BENDIX	X	109	39	17,5	4		

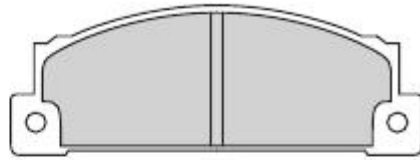

F3000



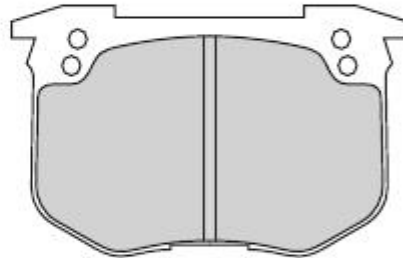



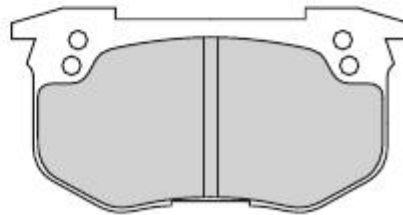

<b>0159</b>	REANULT - TALBOT	BENDIX	X	105	67	18	4	2	130
-------------	------------------	--------	---	-----	----	----	---	---	-----



<b>0160</b>	RENAULT	BENDIX	X	105	54,7	18	4	2	130
-------------	---------	--------	---	-----	------	----	---	---	-----



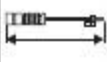

									
0161	CITROEN	CITROEN	X	76,1	82	16	4	4	110

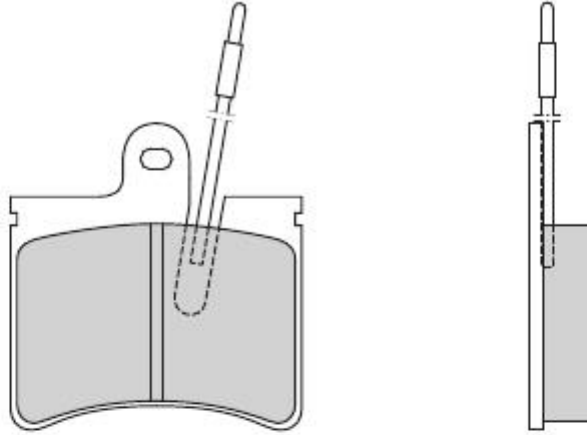



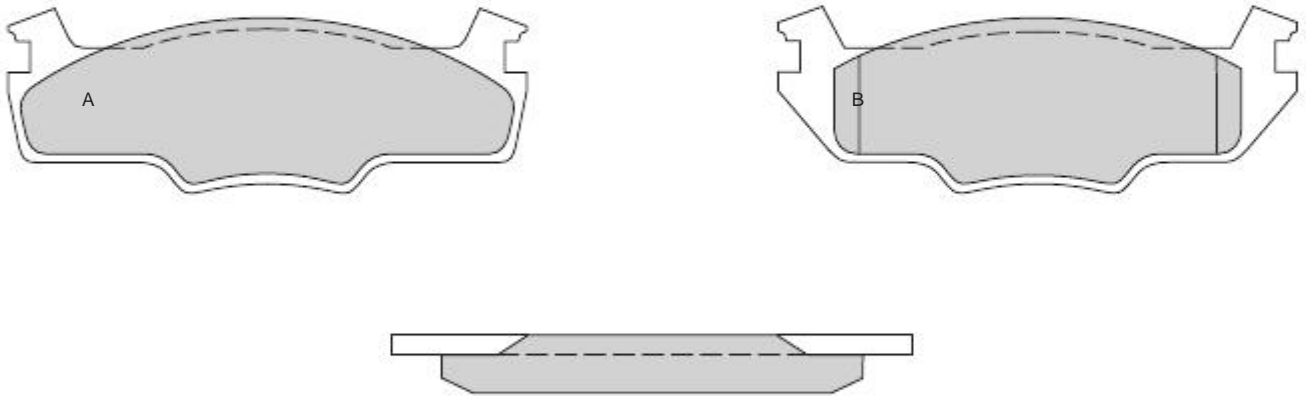



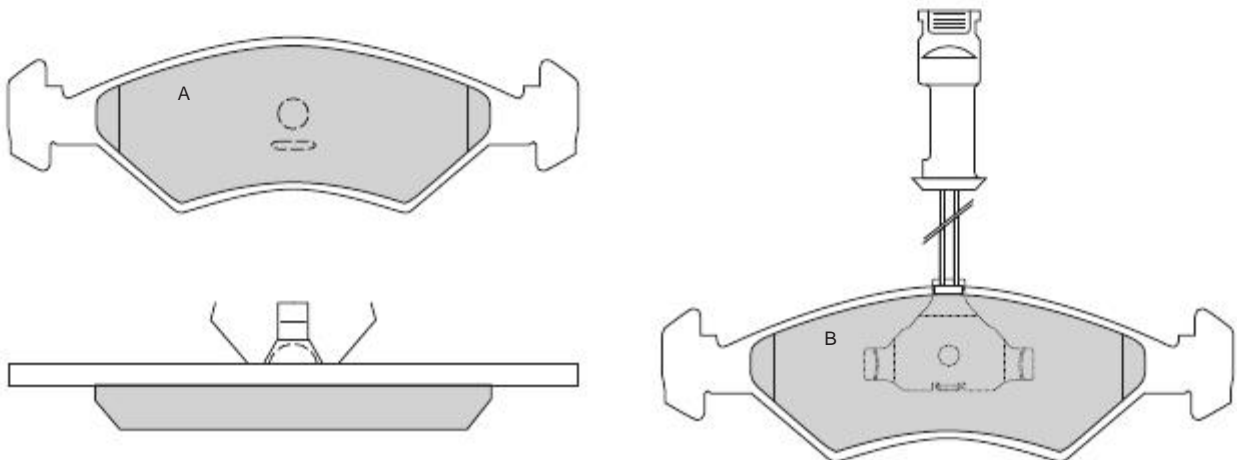

0162	VOLKSWAGEN	ATE	X	138	49	15,3	2A-2B		
------	------------	-----	---	-----	----	------	-------	--	--



0163	FORD	ATE	X	151,3	46,6	17,5	2A-2B	2	160
------	------	-----	---	-------	------	------	-------	---	-----

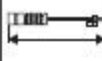

									
0163-1	FORD	ATE	X	X	151,3	46,6	17,5	2A-2B	

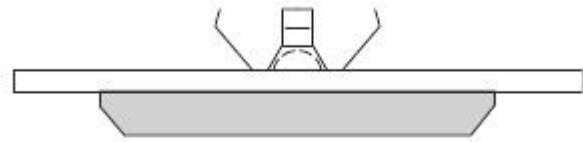
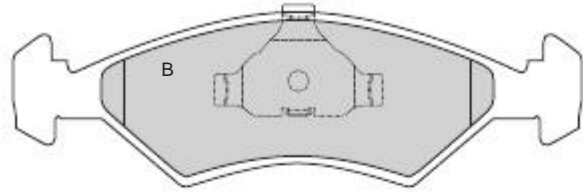



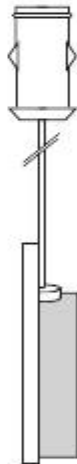
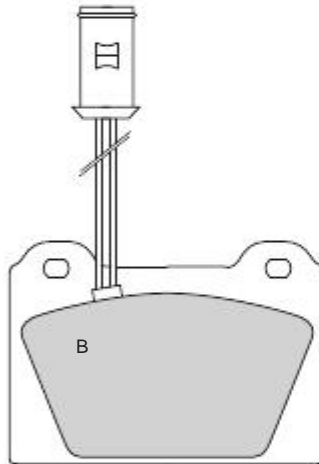
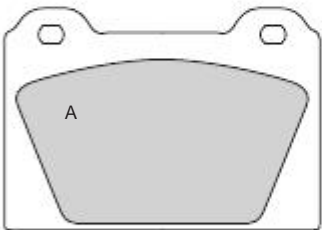



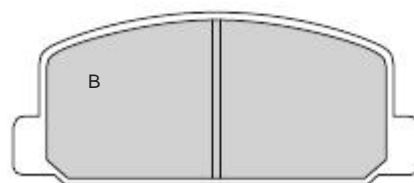
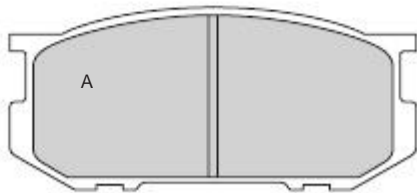



0164	ROVER	ATE	X		83,8	59	14,5	2A-2B	2	160
------	-------	-----	---	--	------	----	------	-------	---	-----



0165	DAIHATSU - TOYOTA	AKEBONO	X		A 107,2 B 109,3	A 48,8 B 45,7	14	2A-2B		
------	-------------------	---------	---	--	--------------------	------------------	----	-------	--	--



									
0166	VOLKSWAGEN	ATE	X	138	49	19,5	2A-2B		

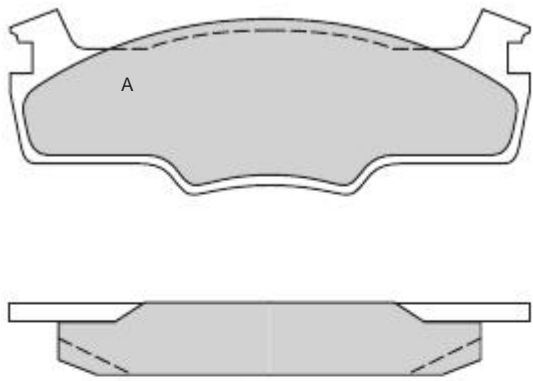



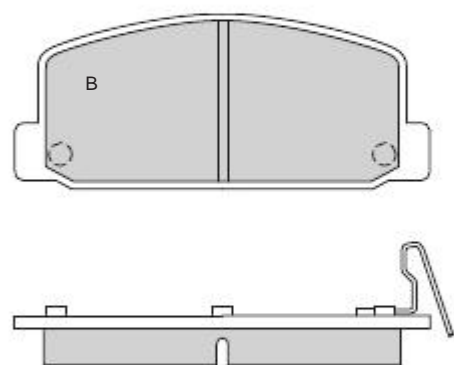
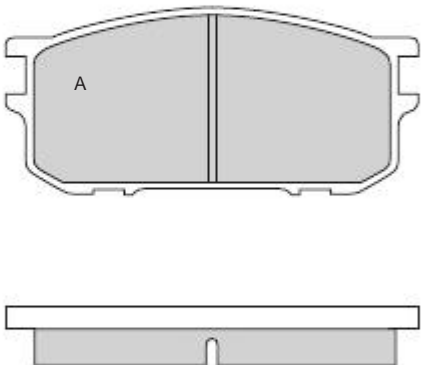



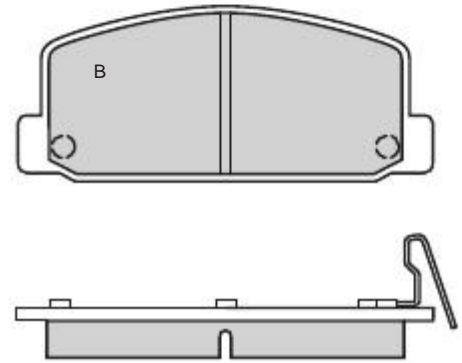
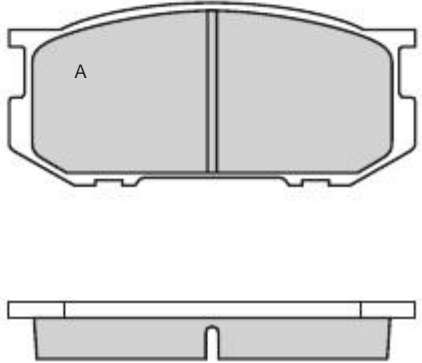



0167	SUBARU	AKEBONO	X	A 106,8 B 109,6	A 48,9 B 46	15	2A-2B		
------	--------	---------	---	--------------------	----------------	----	-------	--	--



0167-1	SUBARU	AKEBONO	X	A 107,2 B 109,6	A 48,8 B 46	14	2A-2B		
--------	--------	---------	---	--------------------	----------------	----	-------	--	--



									
<b>0168</b>	MITSUBISHI - TOYOTA	SUMITOMO	X	128,1	56,3	15	4		

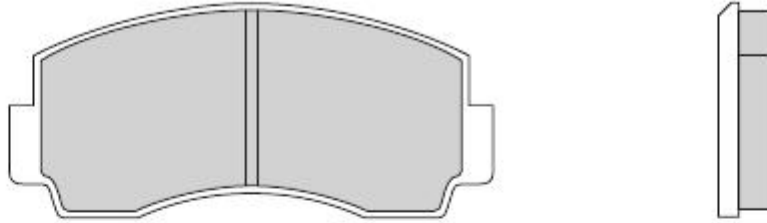



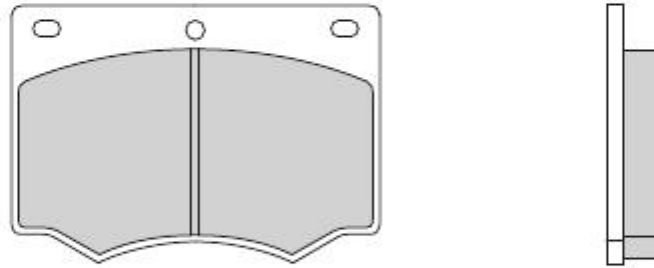



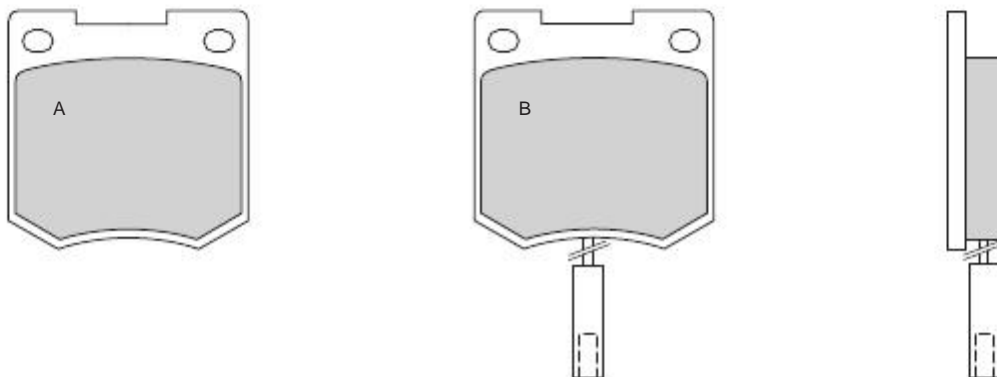



<b>0169</b>	FORD	GIRLING	X	98,2	68	15	4		
-------------	------	---------	---	------	----	----	---	--	--



<b>0171</b>	TALBOT	GIRLING	X	63,4	63,3	14,3	2A-2B	2	175
-------------	--------	---------	---	------	------	------	-------	---	-----



									
<b>0172</b>	MERCEDES - VOLKSWAGEN	ATE	X	89,7	73,8	17,5	4	2	130

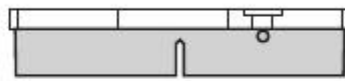
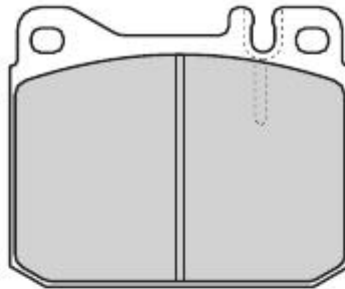



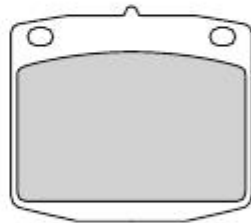



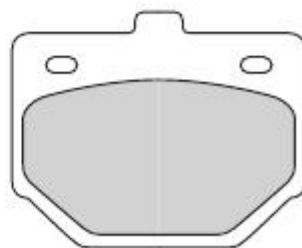

<b>0173</b>	NISSAN	SUMITOMO	X	63,4	57,2	14,5	4		
-------------	--------	----------	---	------	------	------	---	--	--



<b>0174</b>	DAIHATSU - SUZUKI TOYOTA	SUMITOMO	X	77,5	62,5	13,5	4		
-------------	-----------------------------	----------	---	------	------	------	---	--	--

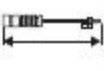

									
0175	TALBOT	BENDIX	X	114,8	48,5	18	2A 1B-1C	2	160

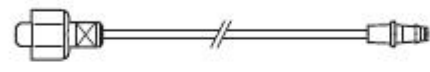
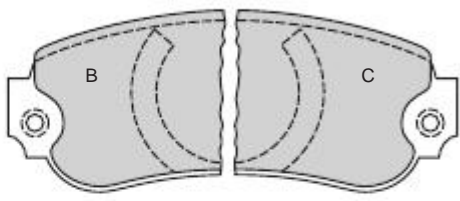
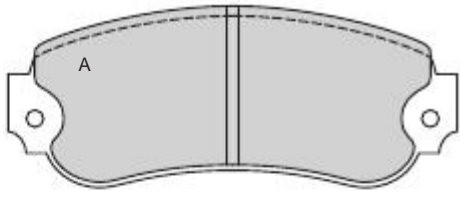



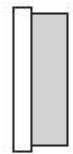
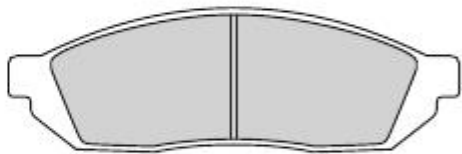



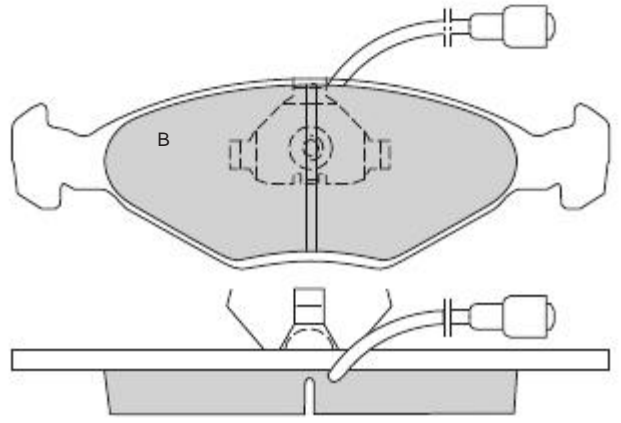
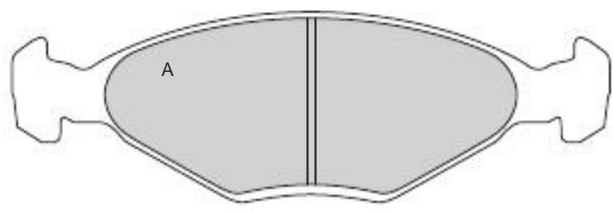

0176	HONDA - SUZUKI VAUXHALL	SUMITOMO	X	119	38	15,5	4		
------	----------------------------	----------	---	-----	----	------	---	--	--



0177	TALBOT	ATE	X	158,3	50,8	18	2A-2B	2	230
------	--------	-----	---	-------	------	----	-------	---	-----

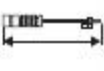

									
<b>0178</b>	FIAT	GIRLING	X	104,6	67,5	19,6	4		

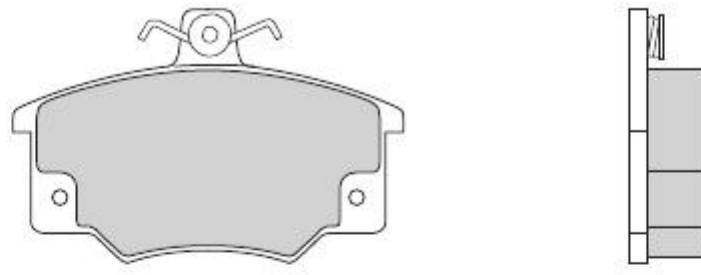



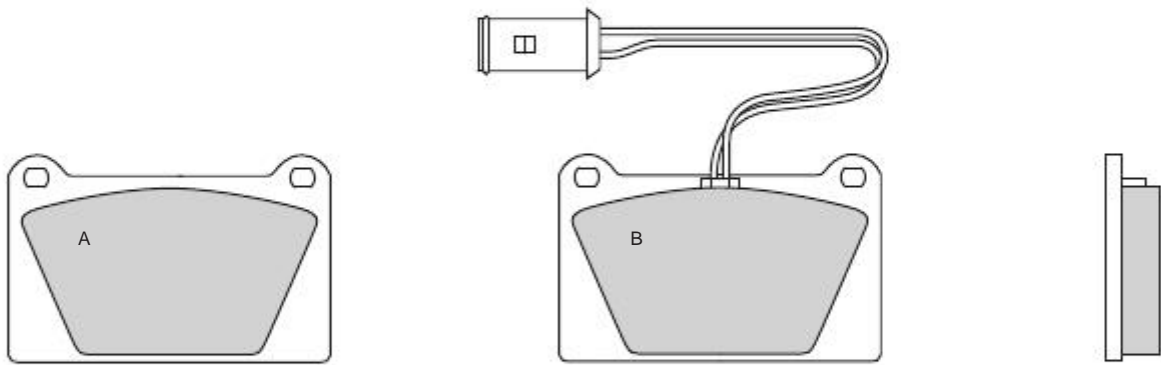



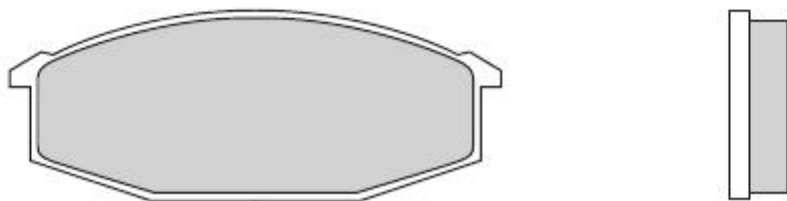

<b>0179</b>	ROVER	GIRLING	X	83,9	55	15	2A-2B	2	160
-------------	-------	---------	---	------	----	----	-------	---	-----



<b>0180</b>	NISSAN - TOYOTA	SUMITOMO	X	130	51	16,2	4		
-------------	-----------------	----------	---	-----	----	------	---	--	--

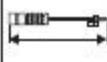

									
0181	RENAULT	BENDIX	X	156	58	18,1	4		

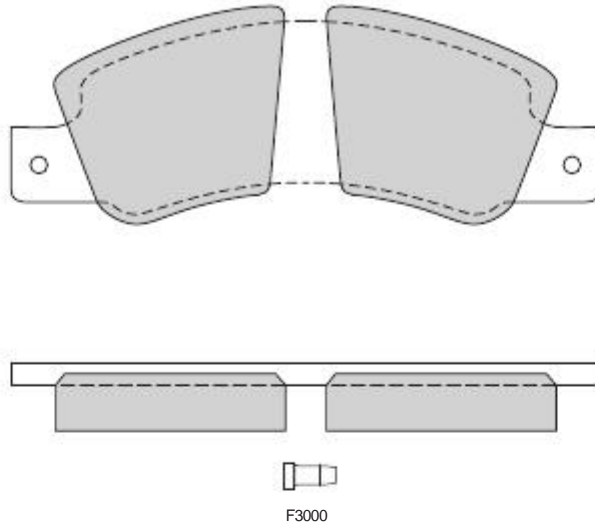

0183	MAZDA	AKEBONO	X	128,4	45,1	14	3A-1B		
------	-------	---------	---	-------	------	----	-------	--	--

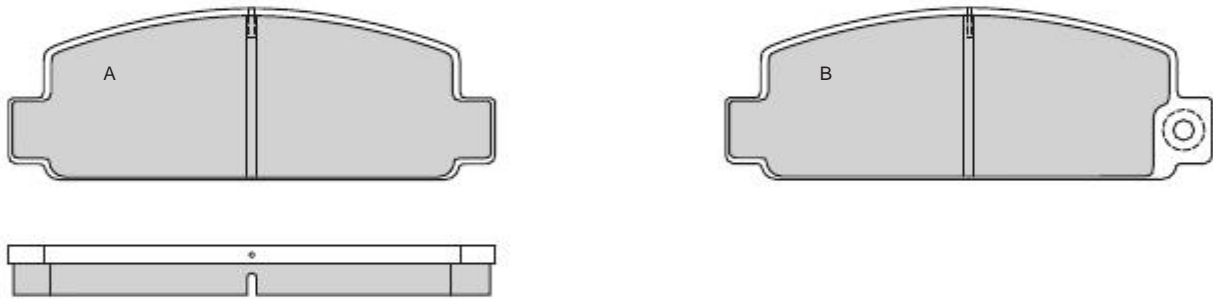



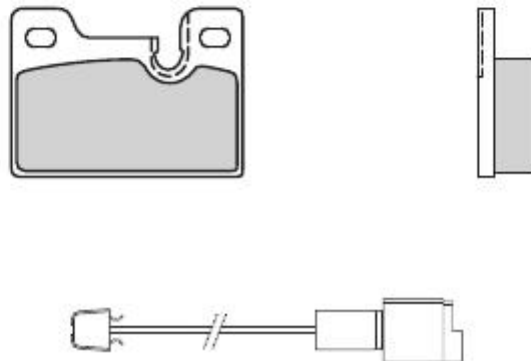







0185	BMW	ATE	X	61,8	44,7	15	4	2	130
------	-----	-----	---	------	------	----	---	---	-----



OPTIONAL



									
0187	ALFA ROMEO - AUDI . FIAT LANCIA - VOLKSWAGEN	GIRLING	X	87	66,8	16,5	4		

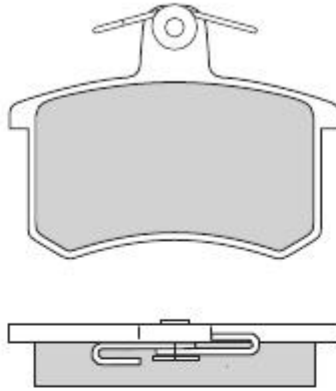



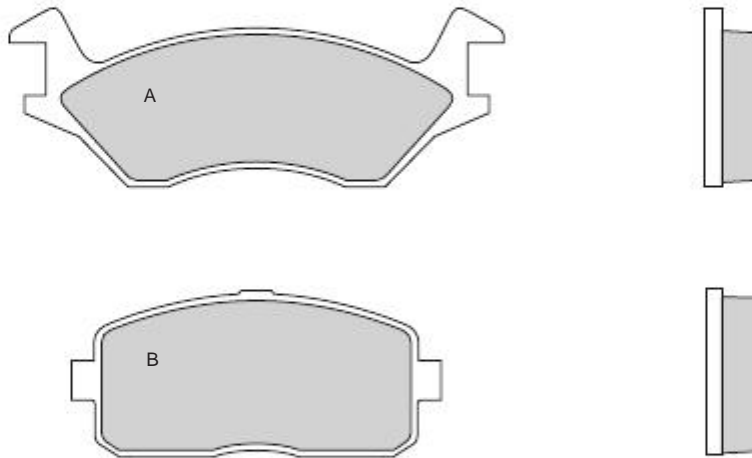



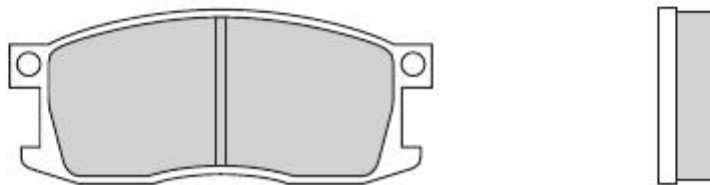

0189	TOYOTA	AKEBONO	X	A 132 B 97,6	A 48 B 44	13,7	2A-2B		
------	--------	---------	---	-----------------	--------------	------	-------	--	--



0190	HONDA	SUMITOMO	X	111,4	47	15,4	4		
------	-------	----------	---	-------	----	------	---	--	--

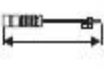

									
<b>0191</b>	MAZDA	SUMITOMO	X	94,9	45,3	14,5	4		

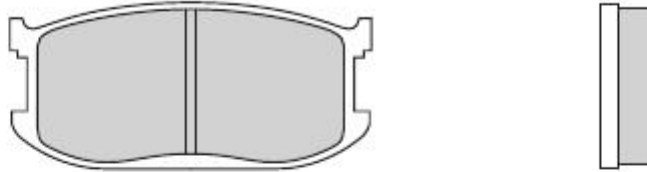



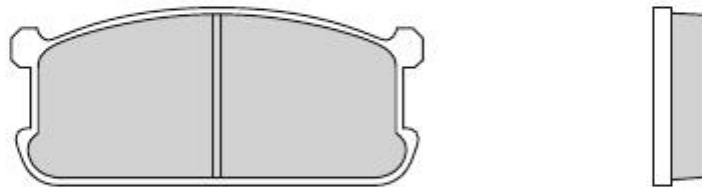



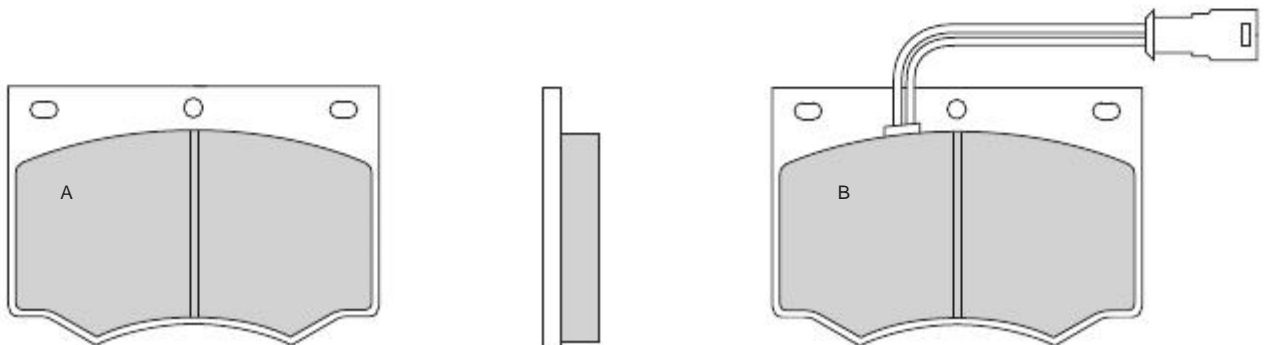

<b>0192</b>	MITSUBISHI	SUMITOMO	X	109	47,5	15,5	4		
-------------	------------	----------	---	-----	------	------	---	--	--



<b>0193</b>	FORD	GIRLING	X	98,2	68	15	2A-2B	2	225
-------------	------	---------	---	------	----	----	-------	---	-----

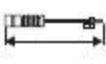

									
0195	CITROEN	CITROEN	X	38	89,4	12	4	4	110

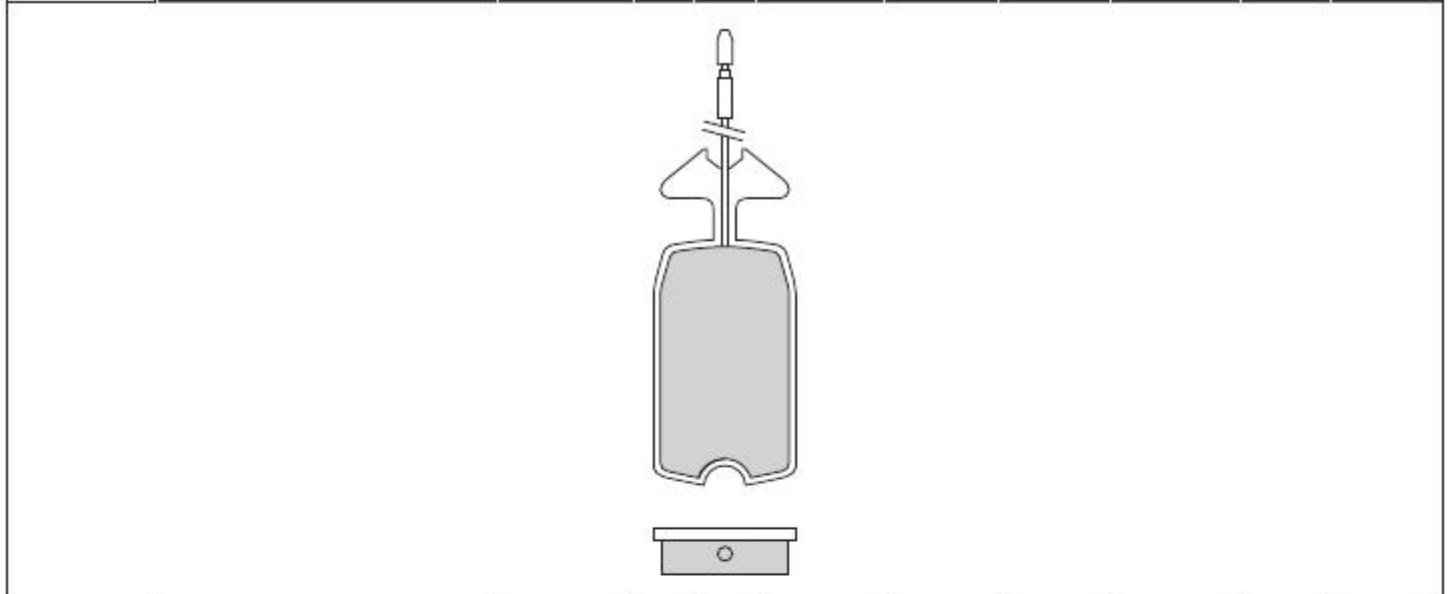



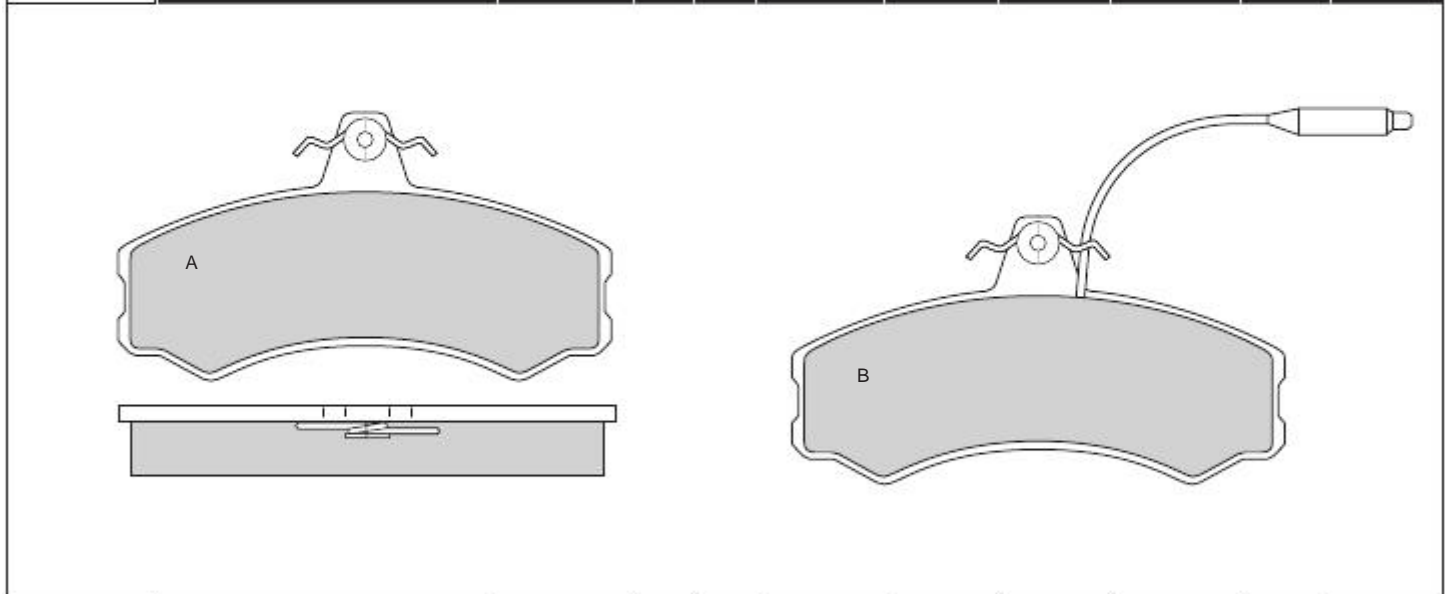



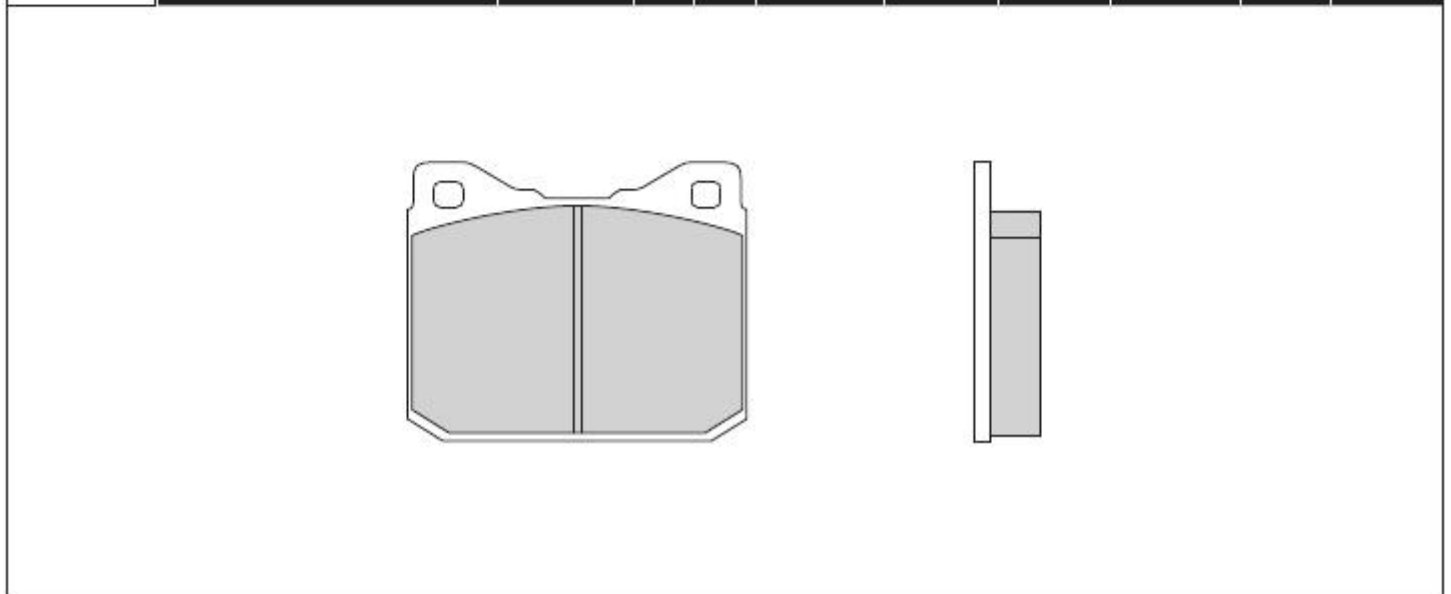

0196	ALFA ROMEO - CITROEN FIAT - MERCEDES - PEUGEOT	GIRLING	X	130	72	19	2A-2B	2	140
------	---	---------	---	-----	----	----	-------	---	-----



0197	VOLKSWAGEN	ATE	X	89,8	73,8	18,5	4		
------	------------	-----	---	------	------	------	---	--	--

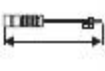

									
0198	HONDA - HYUNDAI - MAZDA MITSUBISHI - TOYOTA	SUMITOMO	X	78,4	59,5	14,3	4		

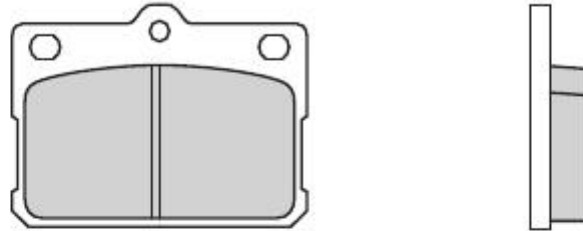

0199	NISSAN	AKEBONO	X	111,7	44	14	2A-2B		
------	--------	---------	---	-------	----	----	-------	--	--

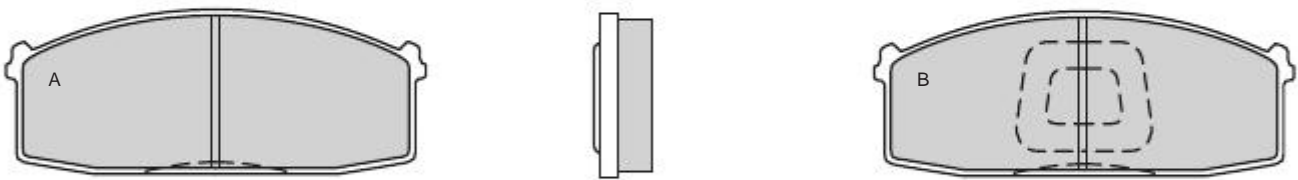

0201	PEUGEOT - RENAULT	GIRLING	X	100	64	18	2A 1B-1C	2	125
------	-------------------	---------	---	-----	----	----	-------------	---	-----

