

0605	ALFA ROMEO	ATE	X	76,95	62	14,8	3A-1B	1	900

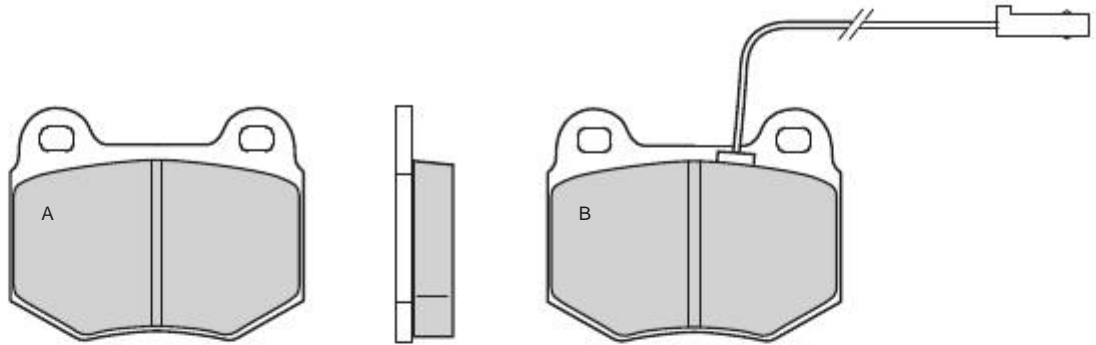

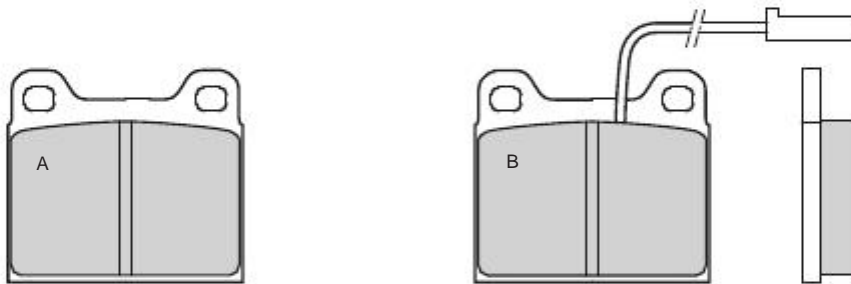

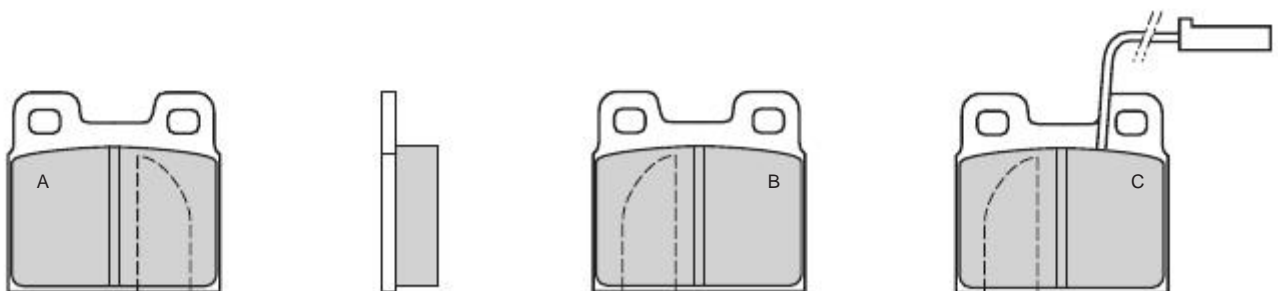





0606	ALFA ROMEO	ATE	X	61,8	56,6	15	3A-1B	1	900
-------------	------------	-----	---	------	------	----	-------	---	-----



0607	ALFA ROMEO	ATE	X	55,75	53,1	15	2A 1B-1C	1	900
-------------	------------	-----	---	-------	------	----	-------------	---	-----

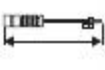

									
0608	ALFA ROMEO	ATE	X	100,05	54,9	15	3A-1B	1	900

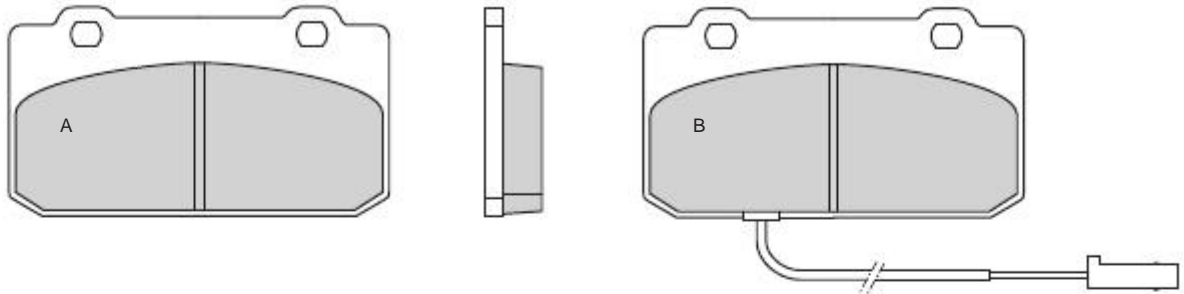



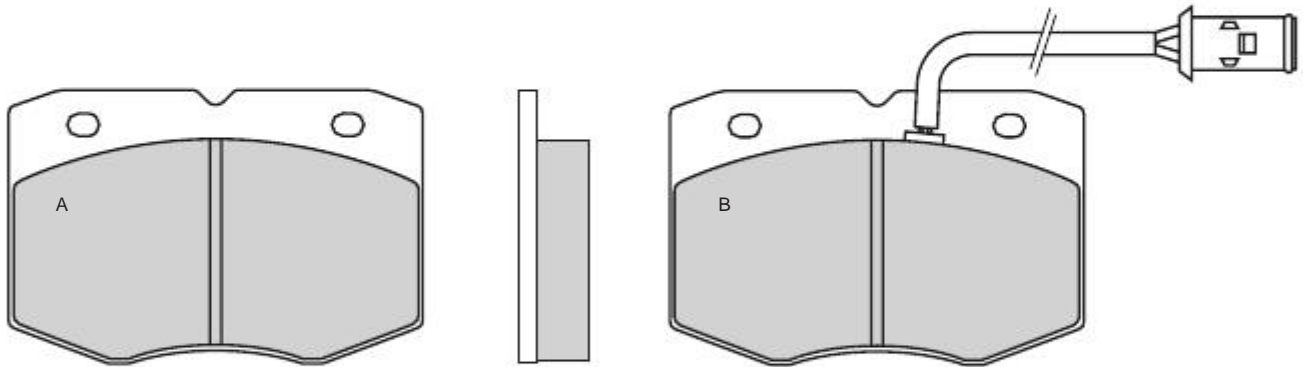



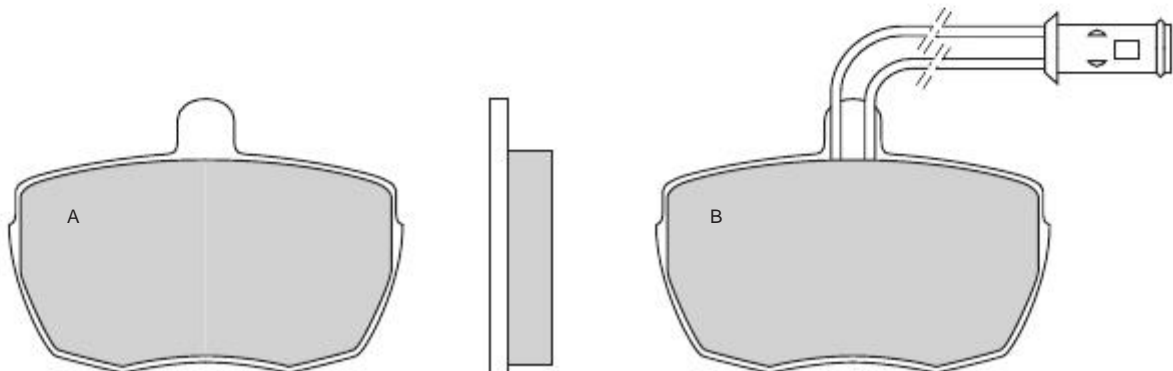

0609	FIAT - IVECO	BREMBO	X	109,7	73	18,3	2A-2B	2	225
-------------	--------------	--------	---	-------	----	------	-------	---	-----



0610	FIAT	LOCKHEED	X	104,8	72,5	18	2A-2B	2	170
-------------	------	----------	---	-------	------	----	-------	---	-----

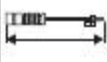

									
0611	FIAT	PERROT	X	149	69	18	2A-2B	2	225

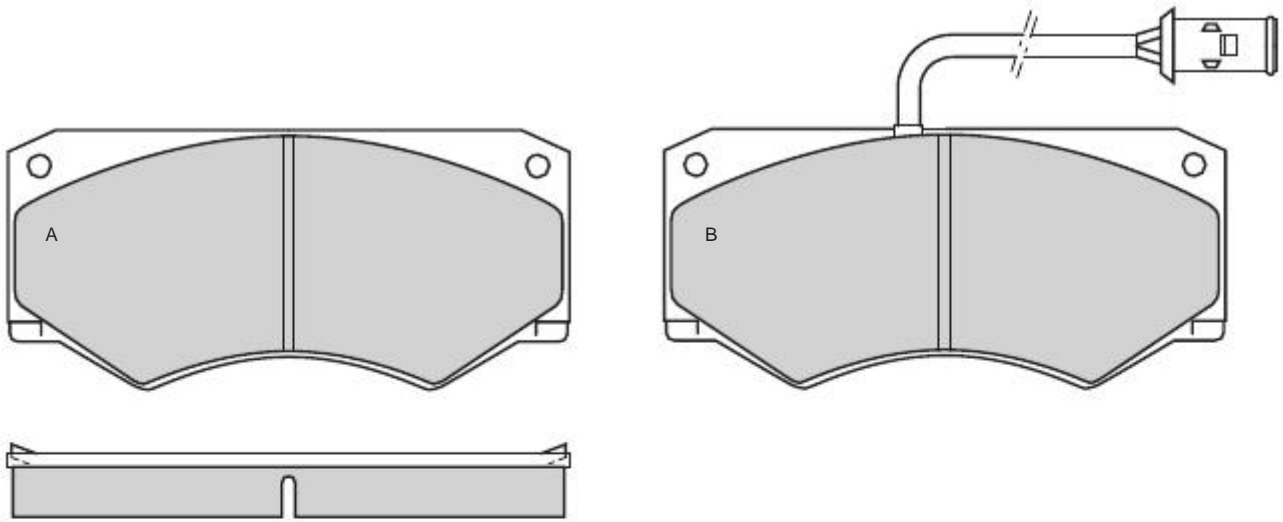



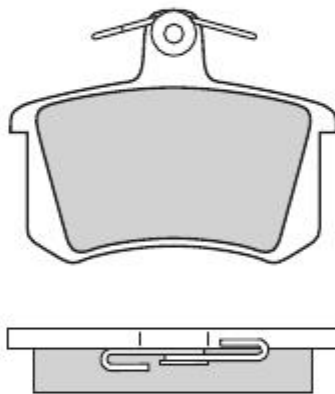



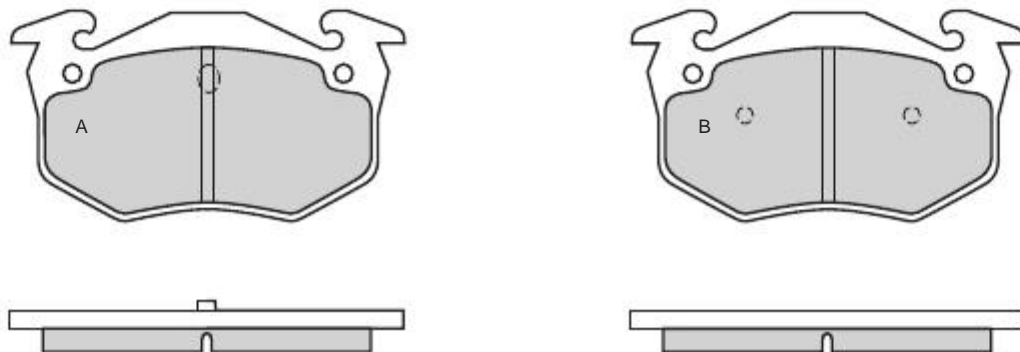

0612	ALFA ROMEO - AUDI	GIRLING	X	87	66,9	16,5	4		
------	-------------------	---------	---	----	------	------	---	--	--



0613	RENAULT	BENDIX	X	105	55,1	11	2A-2B		
------	---------	--------	---	-----	------	----	-------	--	--

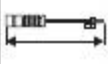

									
0614	CITROEN - FIAT - PEUGEOT	GIRLING	X	144,9	59	19,5	2A-2B	2	200

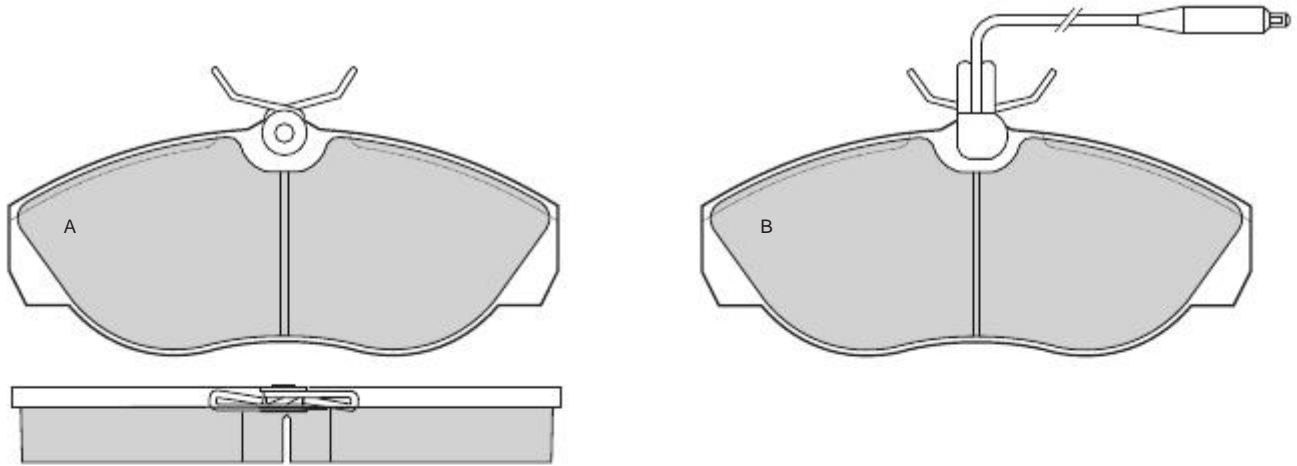



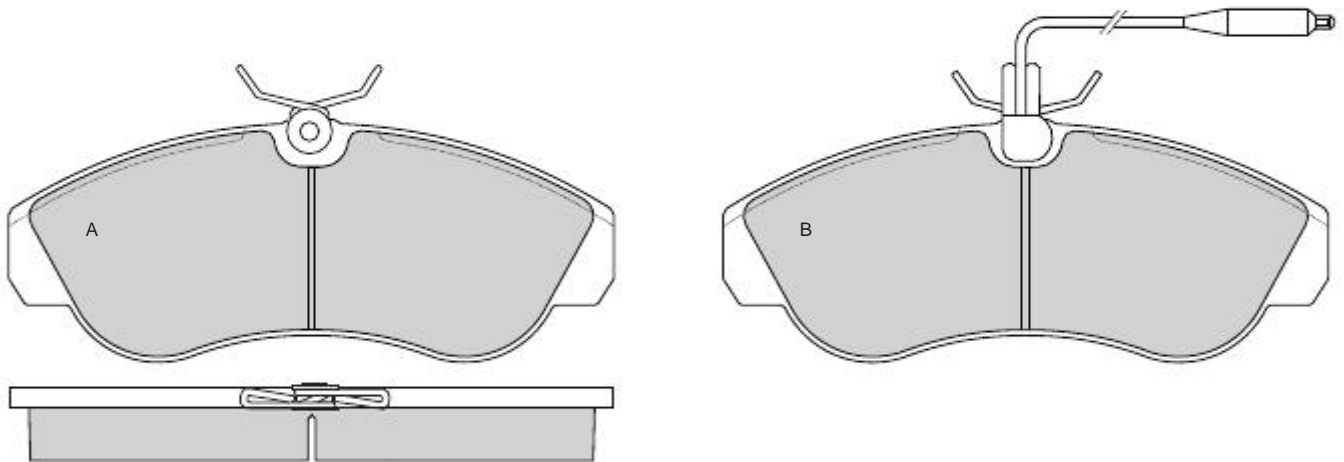



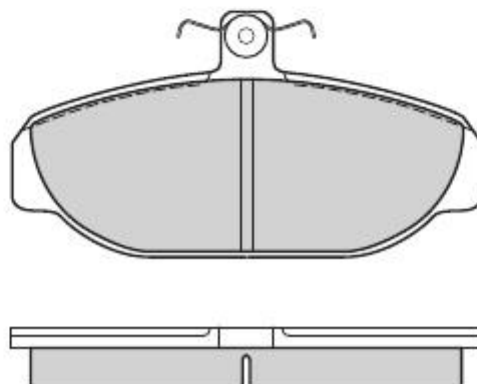

0615	CITROEN - FIAT - PEUGEOT	GIRLING	X	159,9	62,8	19,5	2A-2B	2	220
-------------	--------------------------	---------	---	-------	------	------	-------	---	-----



0616	VOLVO	GIRLING	X	125	65,1	16,6	4		
-------------	-------	---------	---	-----	------	------	---	--	--

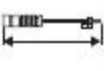

									
0617	TOYOTA	AKEBONO	X	140,3	57,8	15,7	4		

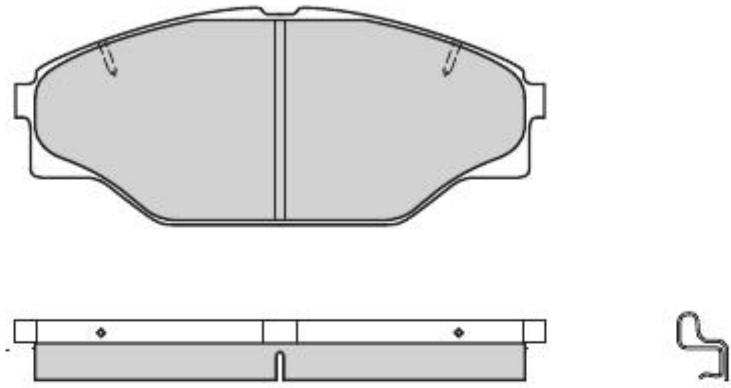



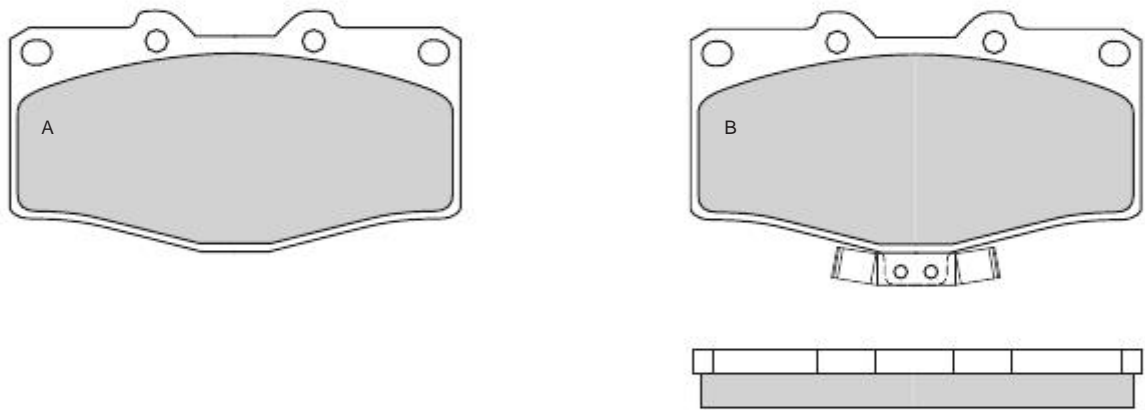



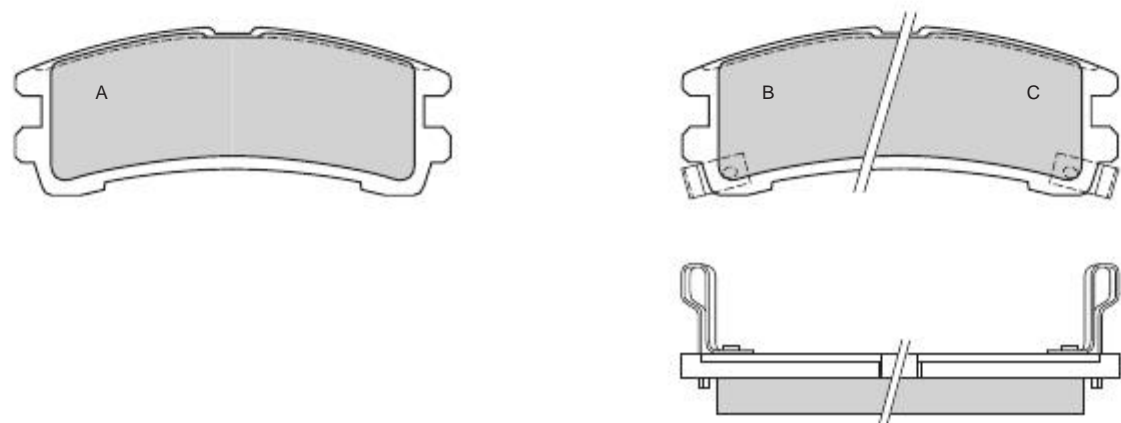

0618	TOYOTA	AKEBONO	X	119,2	A 64,2 B 73,2	15	2A-2B		
-------------	--------	---------	---	-------	------------------	----	-------	--	--

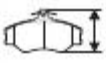

0619	NISSAN	SUMITOMO	X	115	45	15,8	2A 1B-1C		
-------------	--------	----------	---	-----	----	------	-------------	--	--



									
0620	SUZUKI	AKEBONO	X	116,7	45,5	A 15,4 B 15	2A 1B-1C		

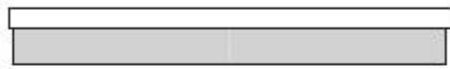
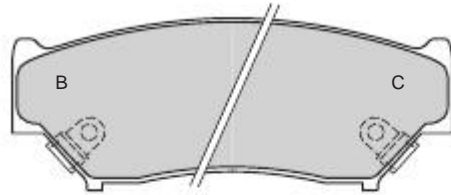
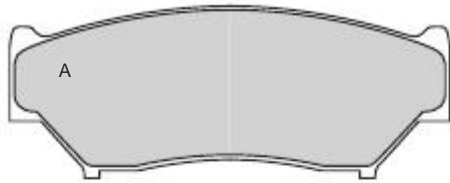



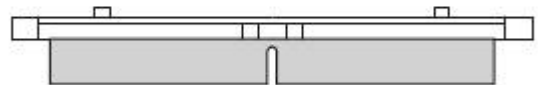
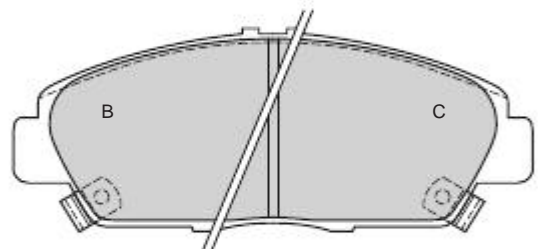
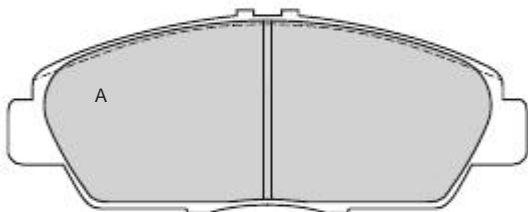



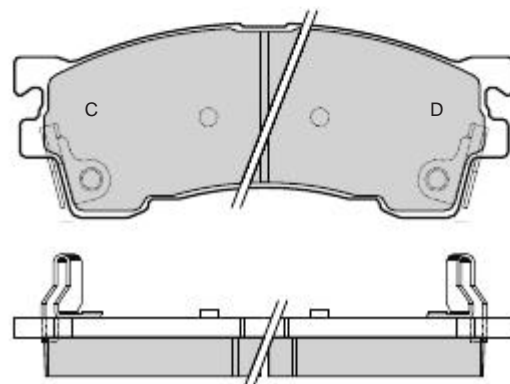
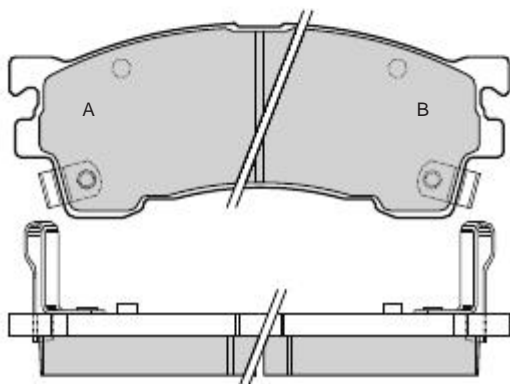

0621	HONDA - ROVER	AKEBONO	X	137,8	53,8	18,3	2A 1B-1C		
------	---------------	---------	---	-------	------	------	-------------	--	--



0622	FORD - MAZDA	SUMITOMO	X	132	51,5	A-B 16,5 C-D 15,5	1A-1B 1C-1D		
------	--------------	----------	---	-----	------	----------------------	----------------	--	--

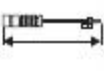

									
0623	TOYOTA	SUMITOMO	X	119,2	72	15	2A-2B		

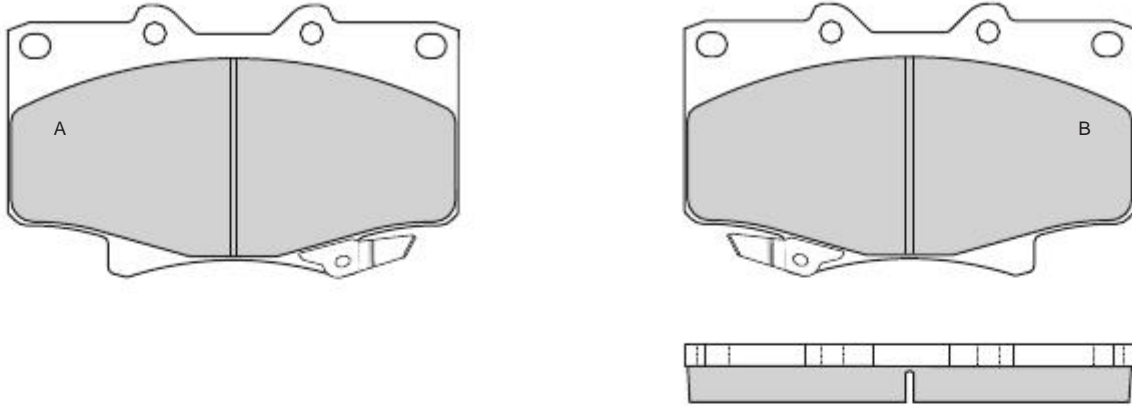



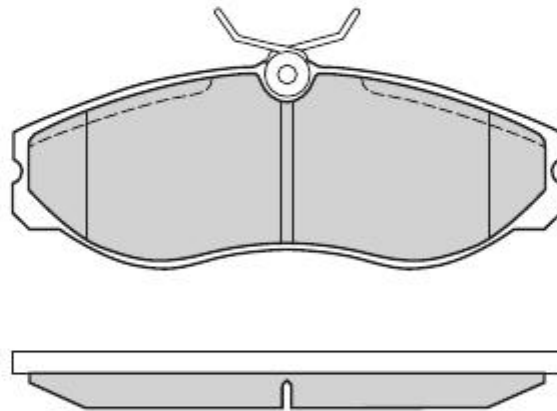



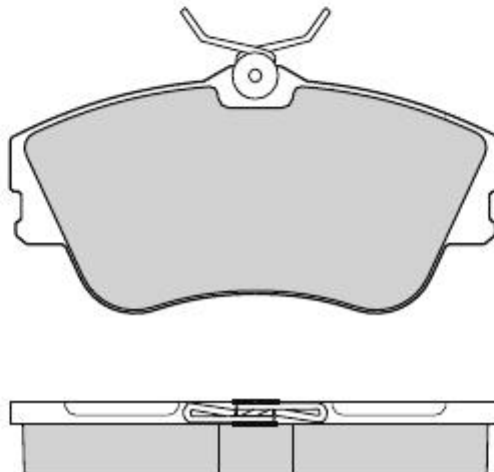

0624	FORD - NISSAN	GIRLING	X	144,9	55,15	15,5	4		
-------------	---------------	---------	---	-------	-------	------	---	--	--



0625	VOLKSWAGEN	GIRLING	X	129,5	65,2	19	4		
-------------	------------	---------	---	-------	------	----	---	--	--

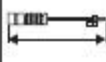

									
0626	FIAT - LANCIA	BENDIX	X	114,9	55,6	17	4	1	480

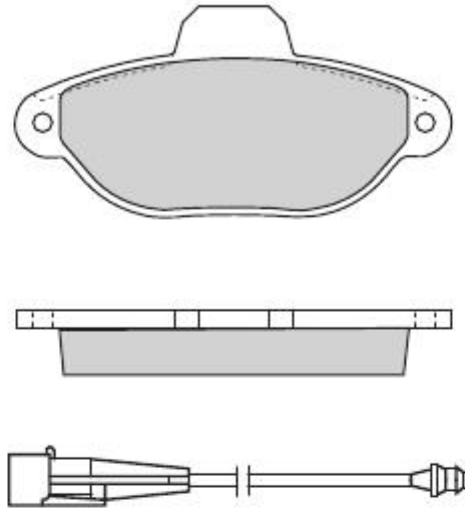



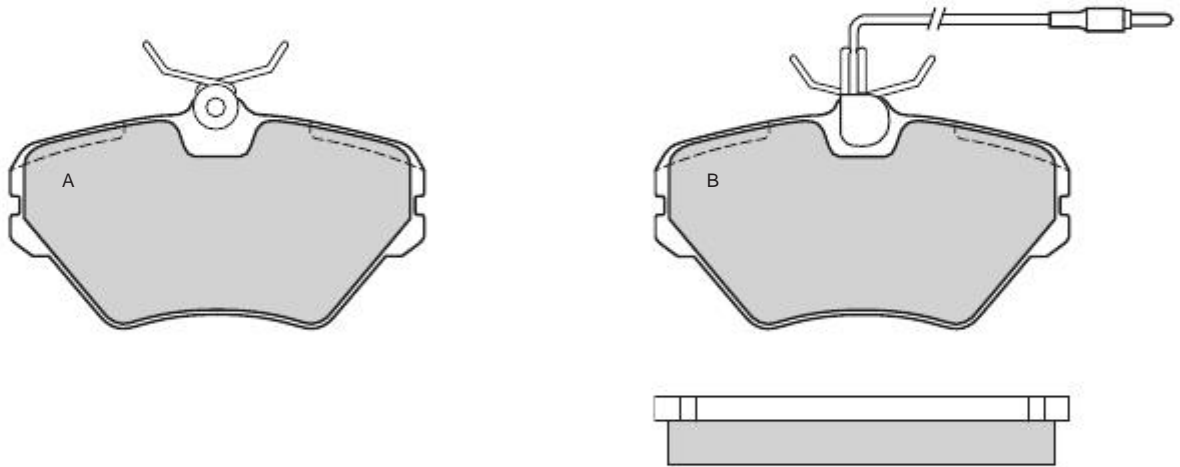



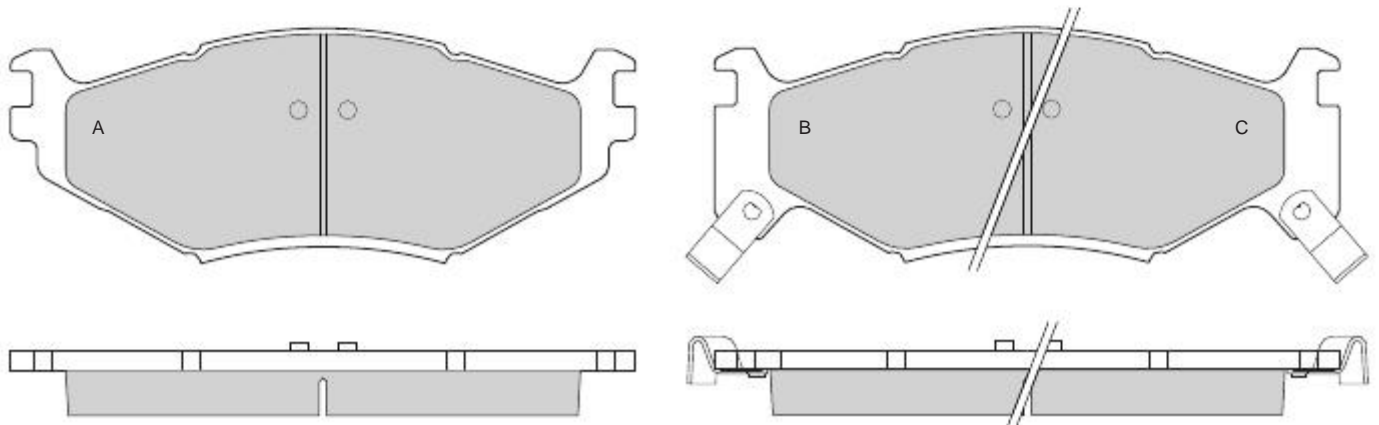

0628	RENAULT	GIRLING	X	110	61	18	2A-2B	2	305
------	---------	---------	---	-----	----	----	-------	---	-----



0629	TALBOT - CHRYSLER - DODGE DODGE TRUCK - PLYMOUTH	KELSEY-HAYES	X	165,1	62,2	17	2A 1B-1C		
------	---	--------------	---	-------	------	----	-------------	--	--

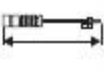

									
0630	FORD - KIA	ATE	X	61,6	51	14,5	4		

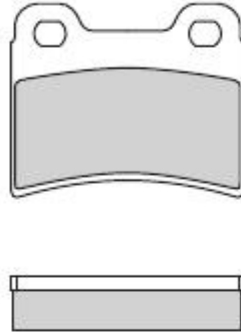



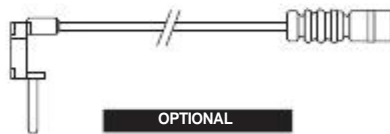
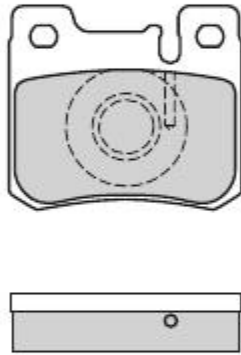



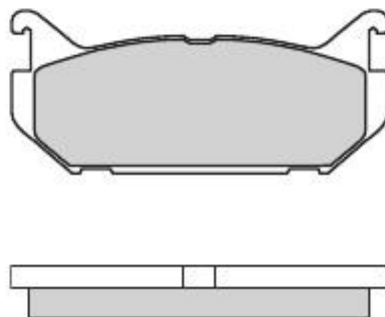

0631	MERCEDES	ATE	X	61,7	54,4	15,2	4	2	130
-------------	----------	-----	---	------	------	------	---	---	-----



0632	FORD - MAZDA	AKEBONO	X	100	43,5	14	4		
-------------	--------------	---------	---	-----	------	----	---	--	--

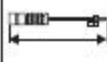

									
0633	TOYOTA	SUMITOMO	X	140	55	15,3	4		

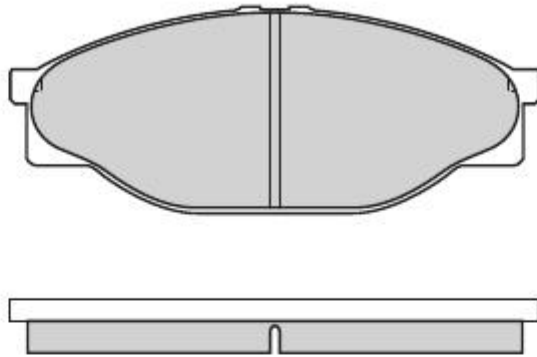



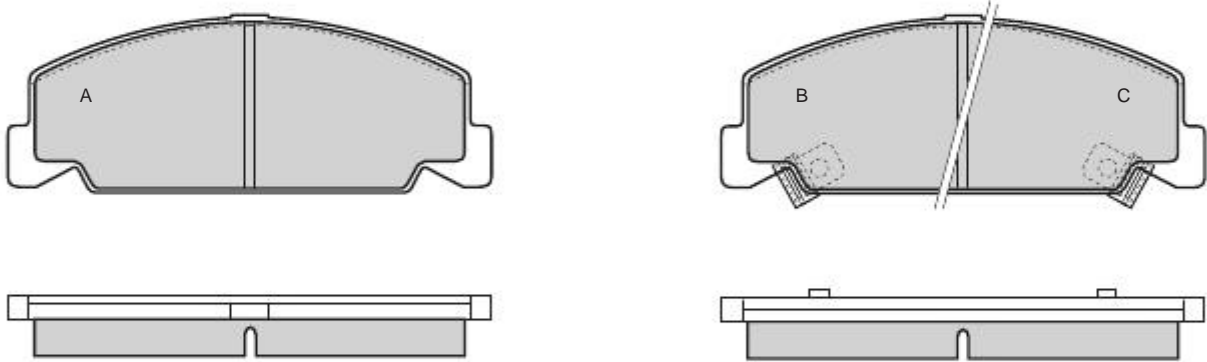



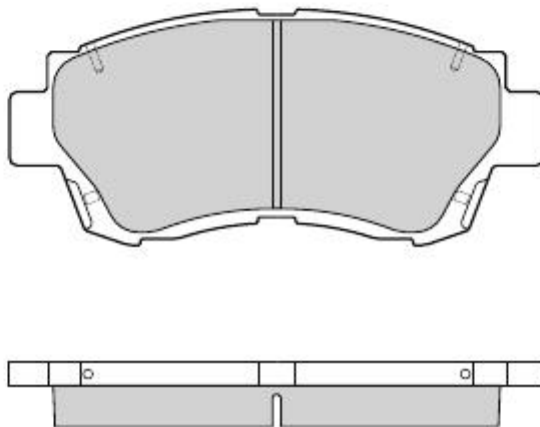

0634	HONDA	AKEBONO	X	127,8	48	15,8	2A 1B-1C		
-------------	-------	---------	---	-------	----	------	-------------	--	--



0635	LEXUS - TOYOTA	SUMITOMO	X	141	62,5	17	4		
-------------	----------------	----------	---	-----	------	----	---	--	--

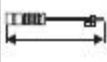

									
0636	PORSCHE	ATE	X	76,8	70	15	4		

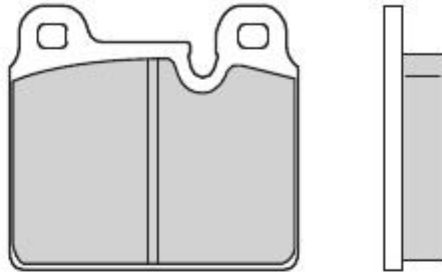



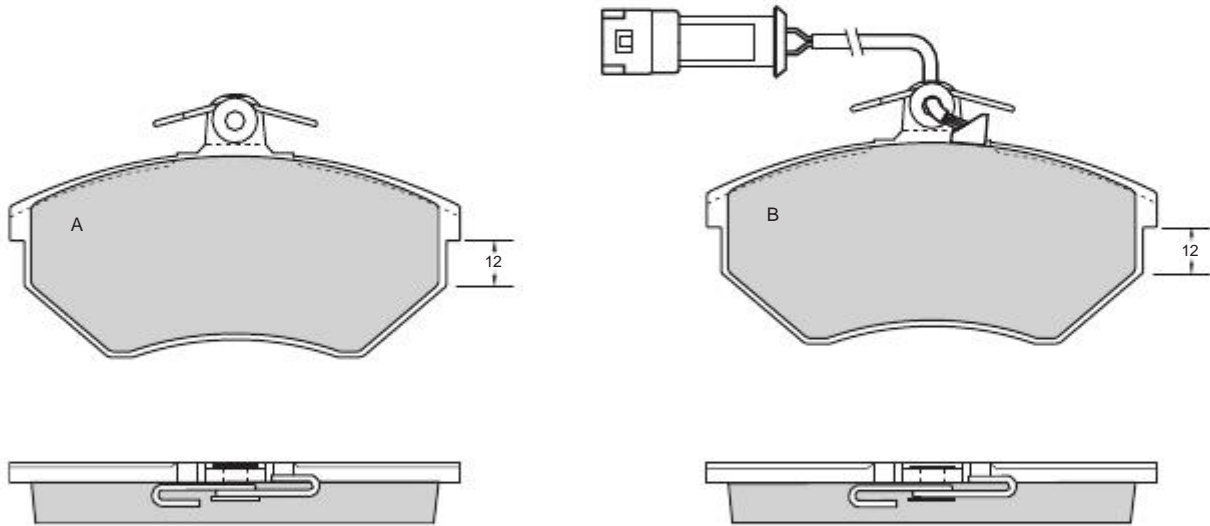



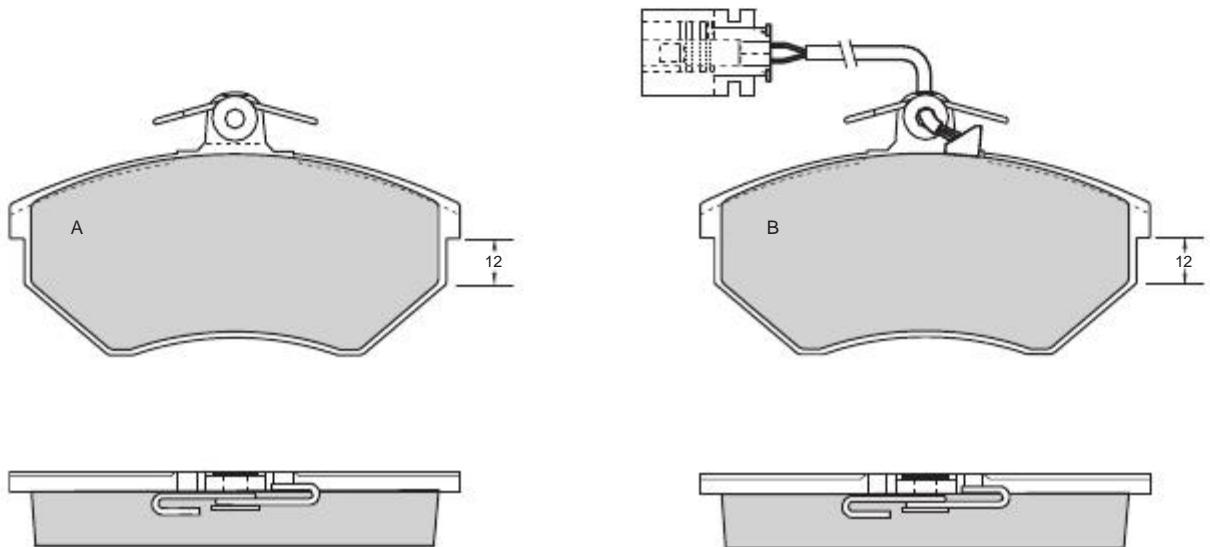

0637	VOLKSWAGEN	GIRLING	X	118,9	69,5	16	2A-2B	2	230
------	------------	---------	---	-------	------	----	-------	---	-----



0638	VOLKSWAGEN	GIRLING	X	118,9	69,5	19,6	2A-2B	2	230
------	------------	---------	---	-------	------	------	-------	---	-----

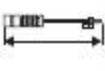

									
0639	DAIHATSU	AKEBONO	X	127,6	52,7	13,8	2A 1B-1C		

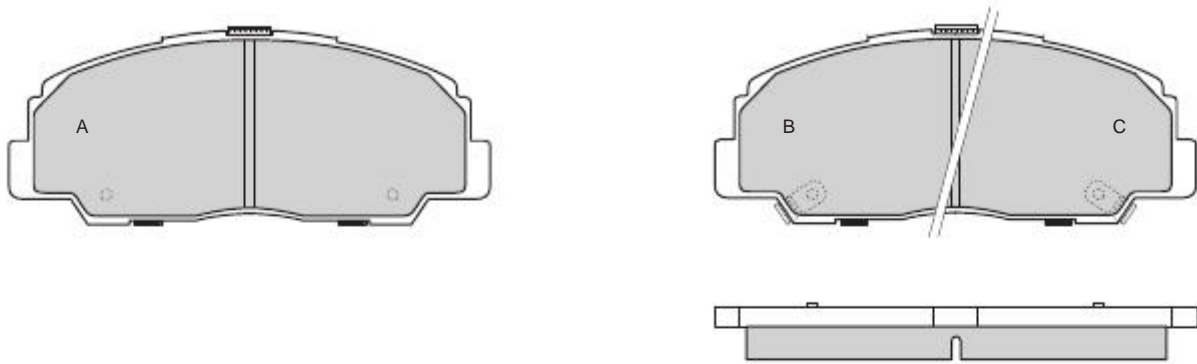



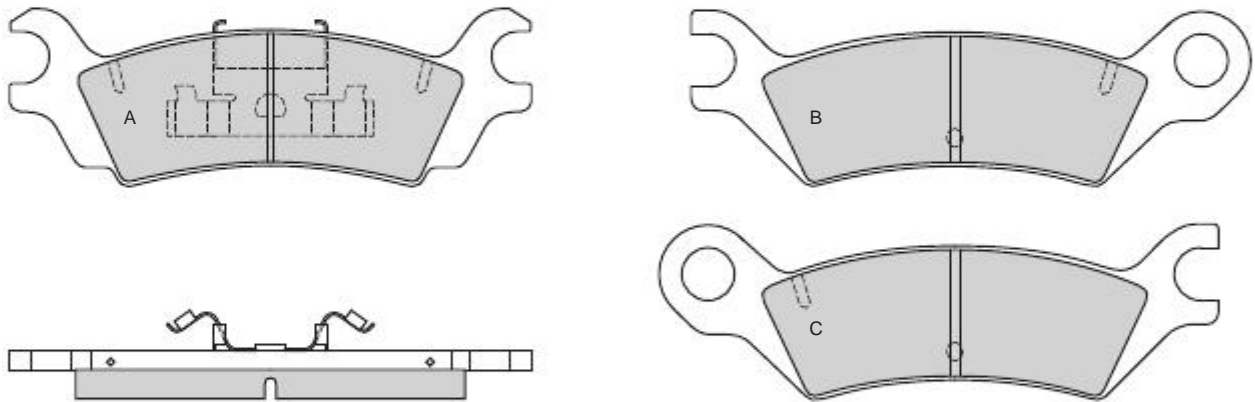



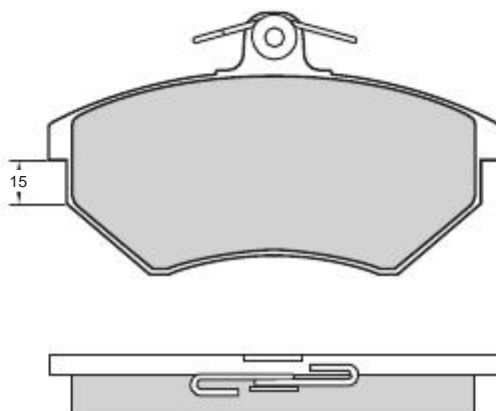

0640	MAZDA	AKEBONO	X	A 138,9 B-C 149,1	47	13	2A 1B-1C		
-------------	-------	---------	---	----------------------	----	----	-------------	--	--



0641	AUDI - SEAT - VOLKSWAGEN	GIRLING	X	118,9	69,5	16,3	4		
-------------	--------------------------	---------	---	-------	------	------	---	--	--

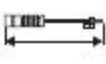

									
0642	AUDI - VOLKSWAGEN	GIRLING	X	118,9	69,5	19,6	4		

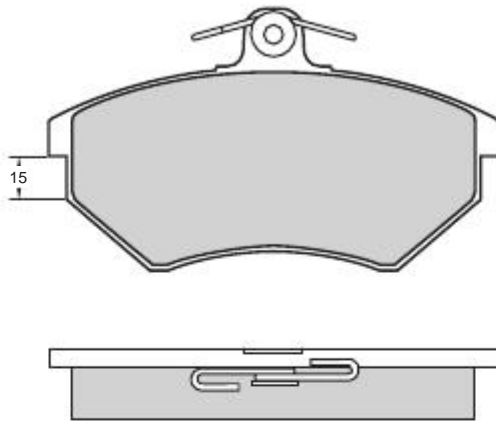



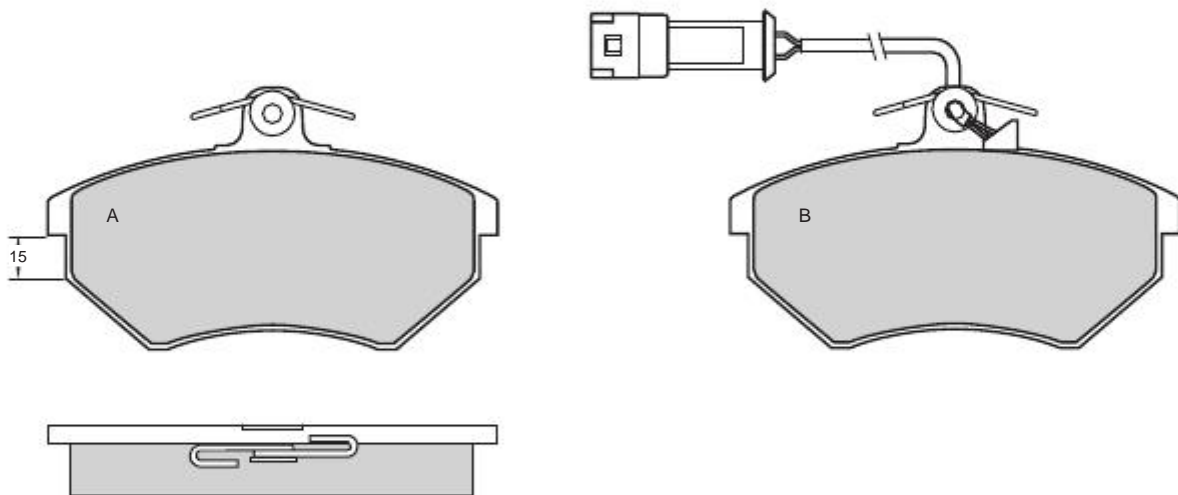



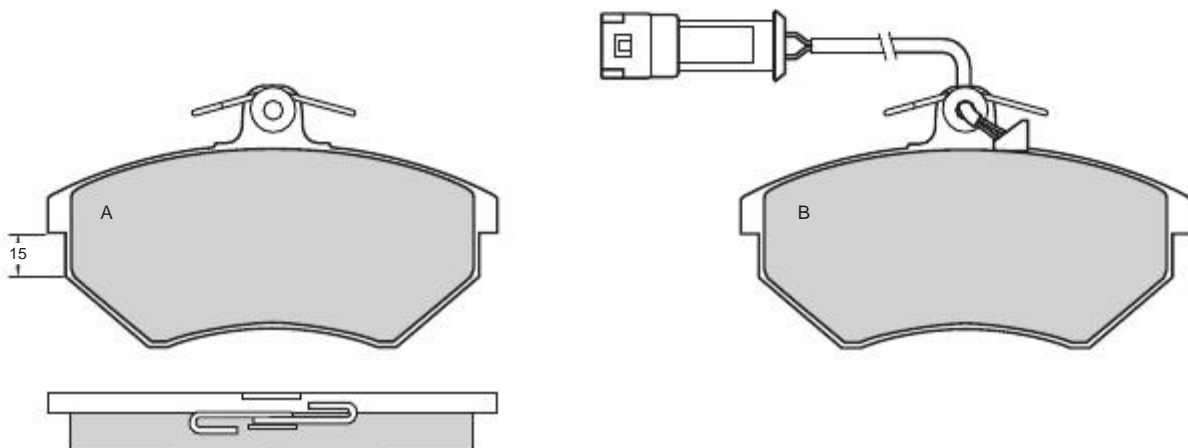

0643	AUDI - VOLKSWAGEN	GIRLING	X	118,9	69,5	19,6	2A-2B	2	260
------	-------------------	---------	---	-------	------	------	-------	---	-----



0644	AUDI - VOLKSWAGEN	GIRLING	X	118,9	69,5	16,3	2A-2B	2	260
------	-------------------	---------	---	-------	------	------	-------	---	-----

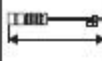

									
0645	SEAT - VOLKSWAGEN	KELSEY-HAYES	X	137,6	A 51,1 B 48,8	17,3	2A-2B		

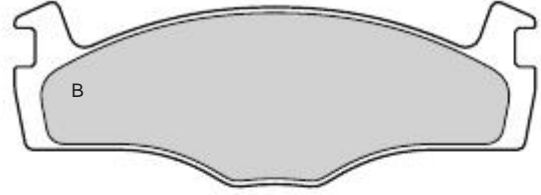
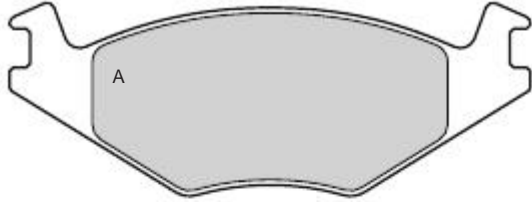



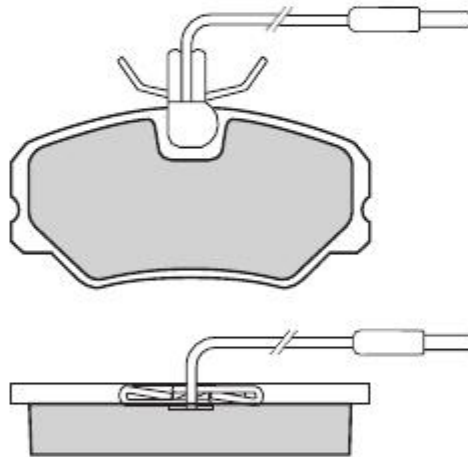



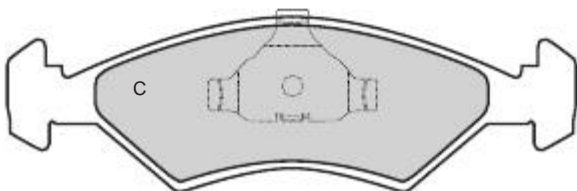
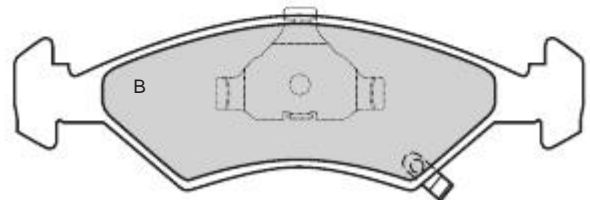

0646	CITROEN - PEUGEOT	GIRLING	X	94,5	48,9	18,5	4	4	305
------	-------------------	---------	---	------	------	------	---	---	-----



0647	KIA	ATE	X	151,3	46,6	18	2A 1B-1C		
------	-----	-----	---	-------	------	----	-------------	--	--

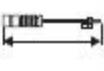

									
0648	HONDA	AKEBONO	X	141	61,2	18,5	2A 1B-1C		

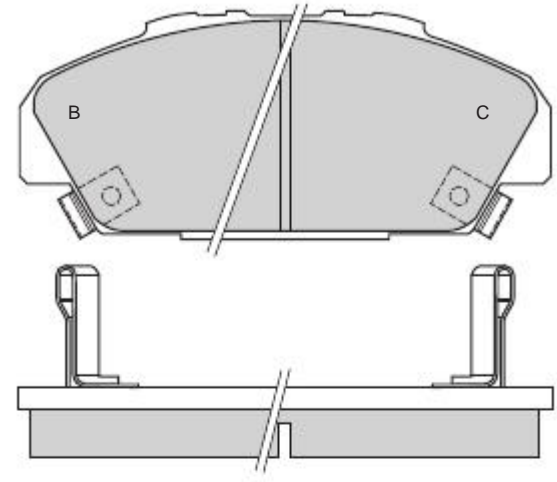
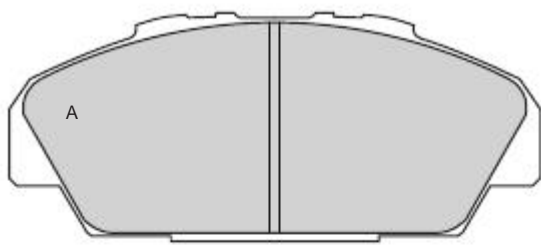



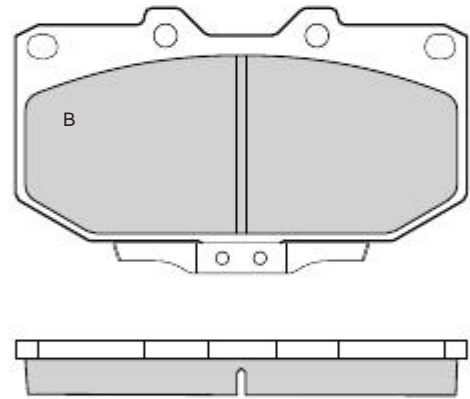
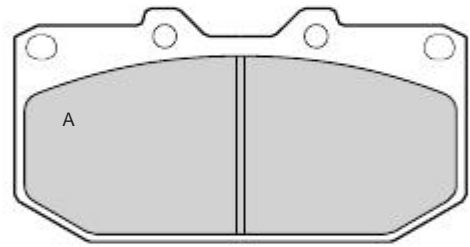



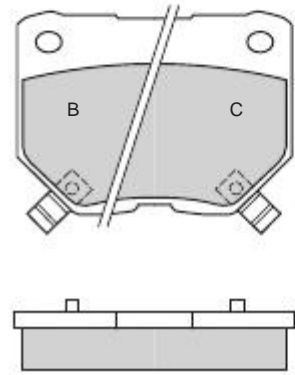
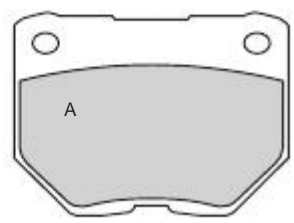

0649	NISSAN	SUMITOMO	X	119,2	A 61,6 B 70,1	14,5	2A-2B		
-------------	--------	----------	---	-------	------------------	------	-------	--	--



0650	NISSAN	SUMITOMO	X	73,2	54,5	15,8	2A 1B-1C		
-------------	--------	----------	---	------	------	------	-------------	--	--

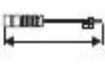

									
0651	BMW	ATE	X	156,3	74,5	19,3	2A-2B		

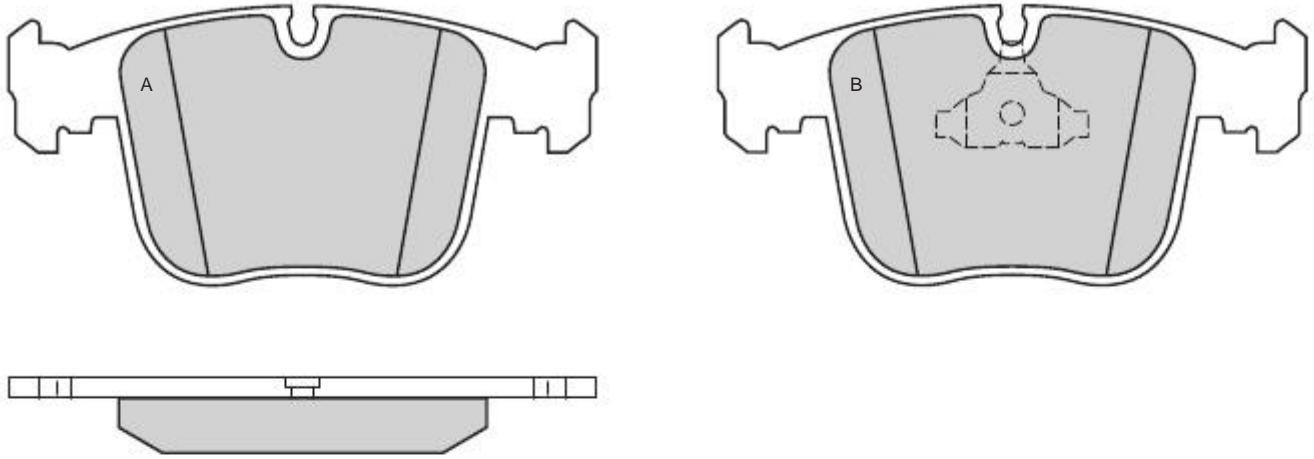



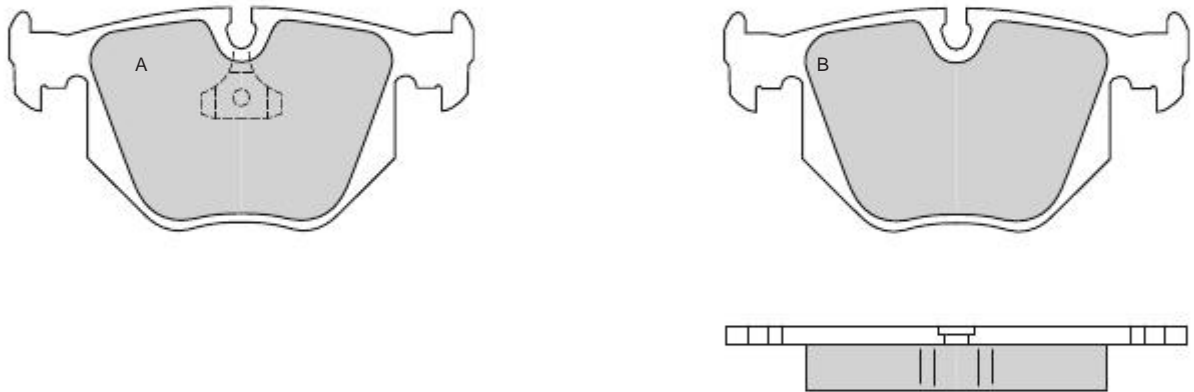





0652	BMW	ATE	X	123	59,4	17,3	2A-2B		
-------------	------------	------------	----------	------------	-------------	-------------	--------------	--	--



0653	MERCEDES	ATE	X	61,7	69,6	15,7	4		
-------------	-----------------	------------	----------	-------------	-------------	-------------	----------	--	--

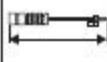

									
0654	TOYOTA	SUMITOMO	X	128	53	15,6	2A-2B		

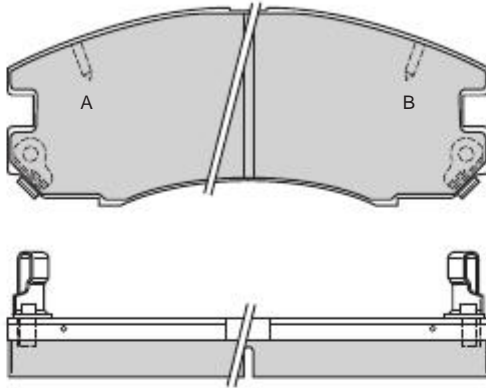



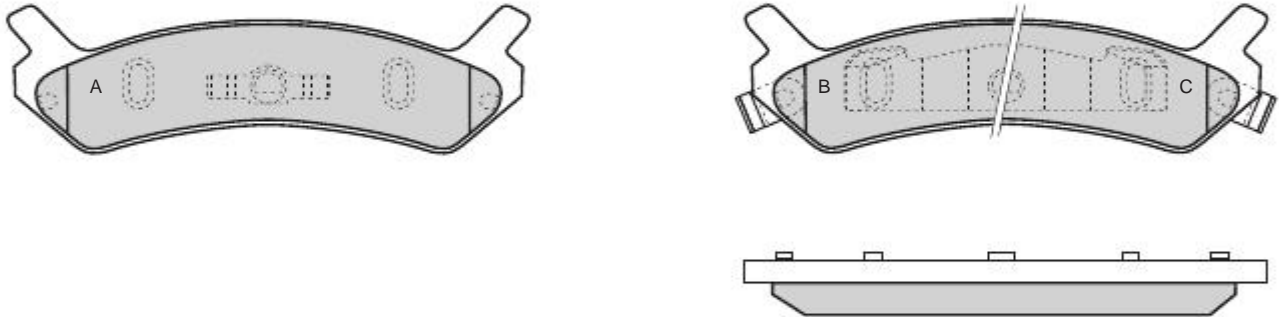



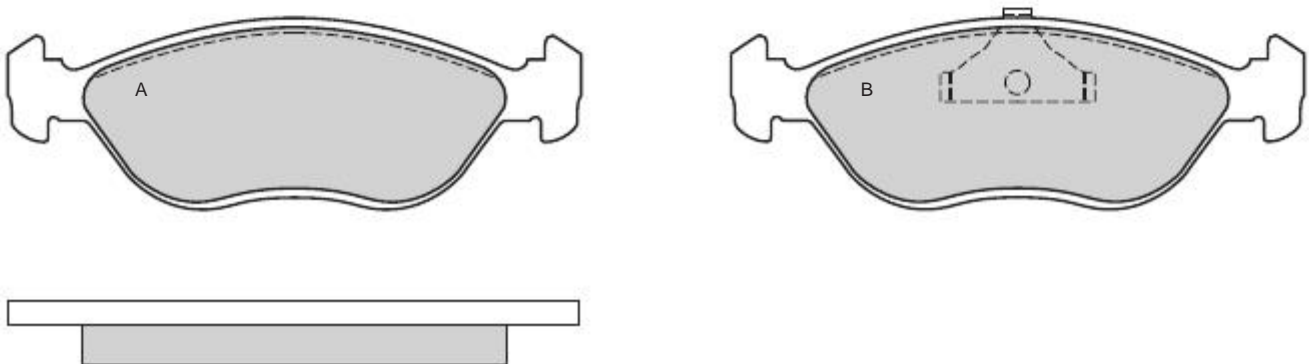

0655	HYUNDAI	AKEBONO	X	137,9	39	14,5	2A 1B-1C		
-------------	---------	---------	---	-------	----	------	-------------	--	--



0656	VOLVO	ATE	X	151,4	50,7	17,5	2A-2B		
-------------	-------	-----	---	-------	------	------	-------	--	--

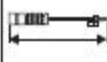

									
0657	MERCEDES	ATE	X	99,6	84,5	18,3	4		

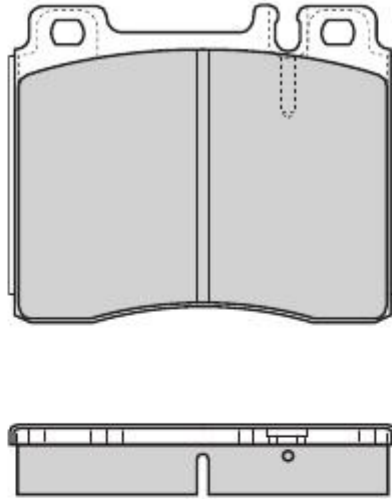



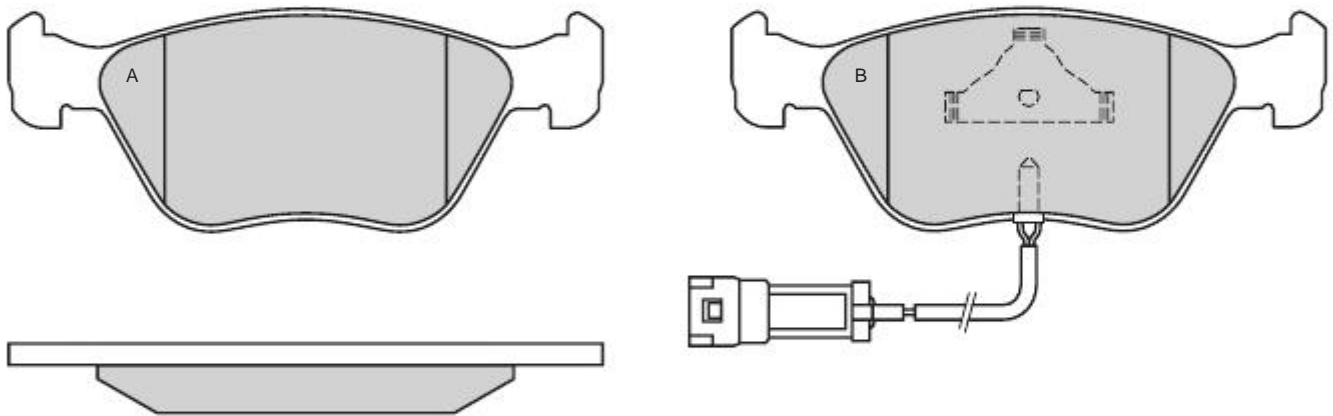



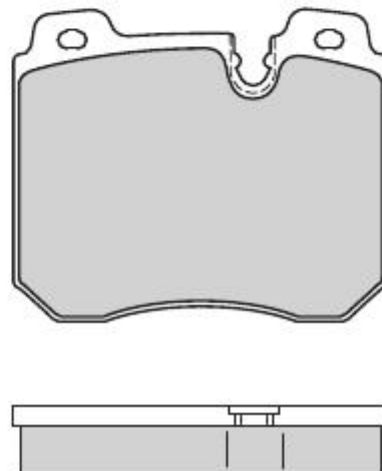

0658	FORD	ATE	X	156,5	58,5	18,7	2A-2B	2	280
-------------	------	-----	---	-------	------	------	-------	---	-----



0659	BMW	ATE	X	99,8	83	18	4		
-------------	-----	-----	---	------	----	----	---	--	--

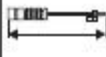

									
0660	FERRARI - BMW	BREMBO	X	119,9	73,5	18	4		

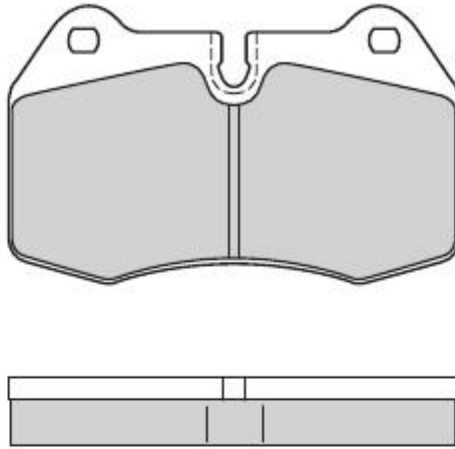



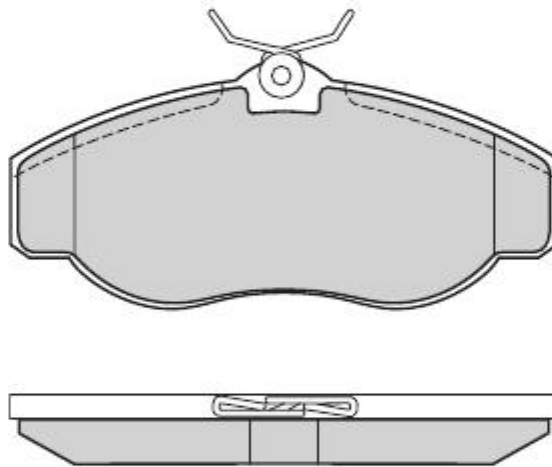



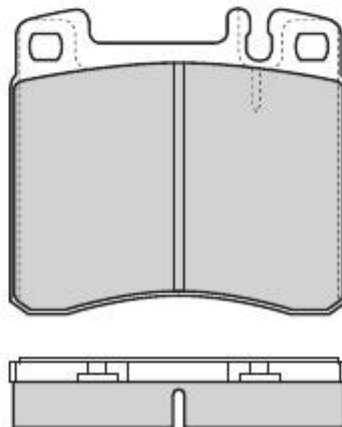

0661	LAND ROVER	GIRLING	X	145	67	19,2	4		
-------------	------------	---------	---	-----	----	------	---	--	--



0662	MERCEDES	ATE	X	89,7	81	18,2	4		
-------------	----------	-----	---	------	----	------	---	--	--

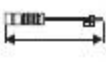

									
0663	SUBARU	AKEBONO	X	127,8	58	17	2A 1 B - 1C		

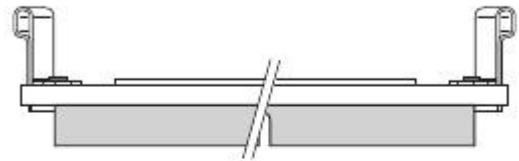
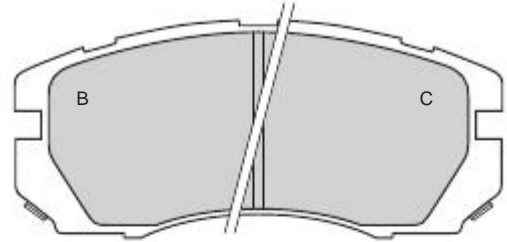
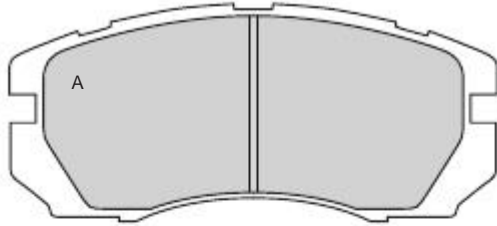



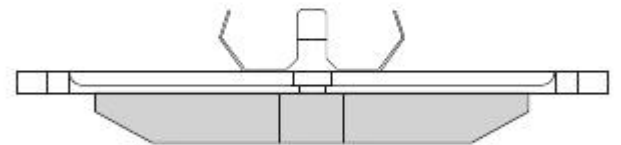
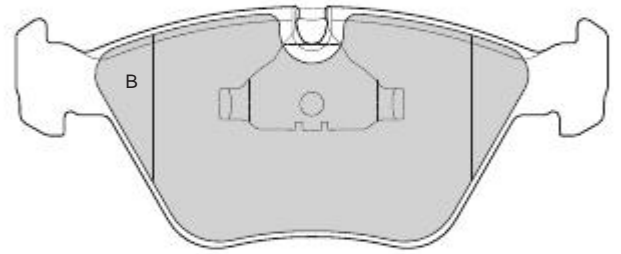
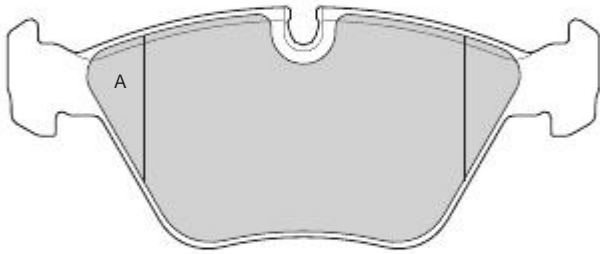



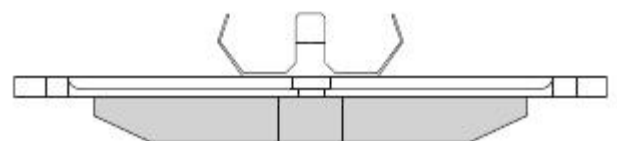
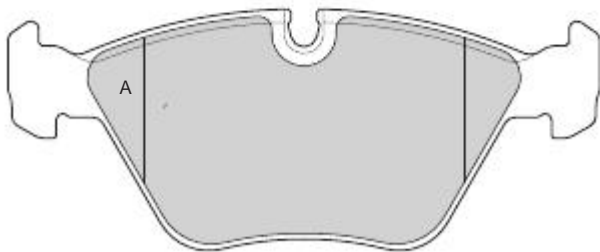











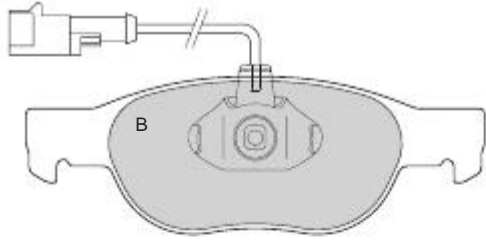
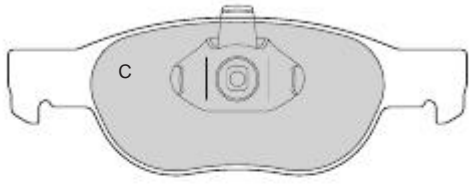
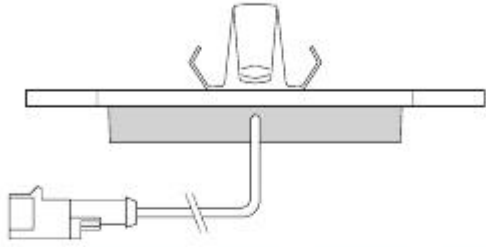
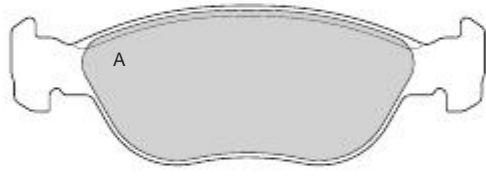
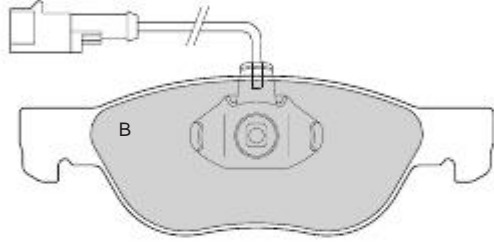

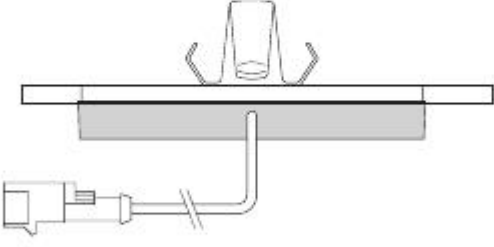



0664	AUDI	ATE	X	156,4	64	18,7	2A-2B		
------	------	-----	---	-------	----	------	-------	--	--



0665	JAGUAR	ATE	X	156,4	64	17,5	2A-2B		
------	--------	-----	---	-------	----	------	-------	--	--

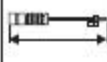

									
0666	FIAT - LANCIA	ATE	X	151,3	52	17,5	2A 1 B - 1C	1	220
 		 							
0667	ALFA ROMEO - FIAT LANCIA	ATE	X	156,3	52,6	17,5	2A 1 B - 1C	1	220
 		 							
0668	DAEWOO	MANDO	X	108,2	39	13,5	4		
 									

									
0669	FIAT	ATE	X	151,2	52,5	17,8	2A-2B	2	250

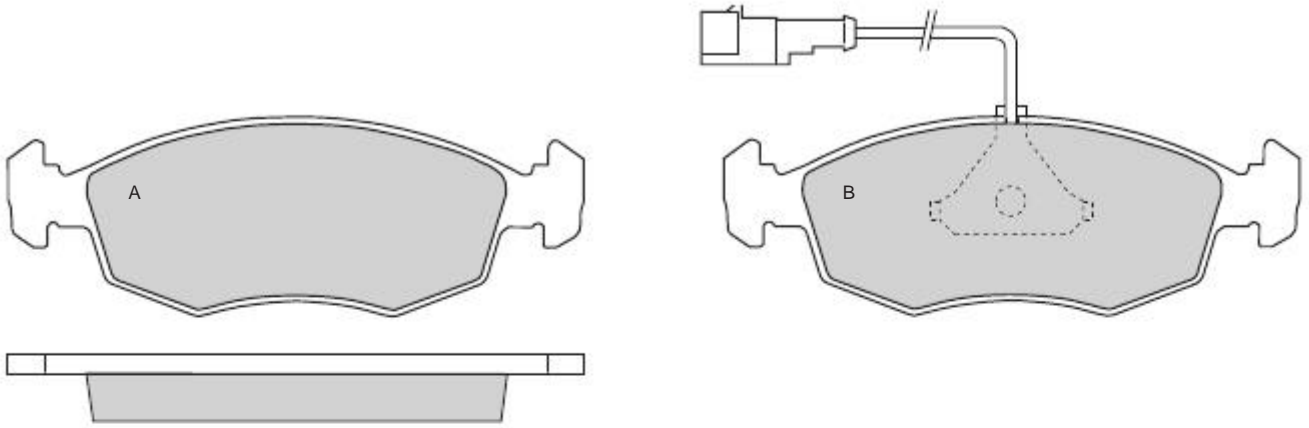



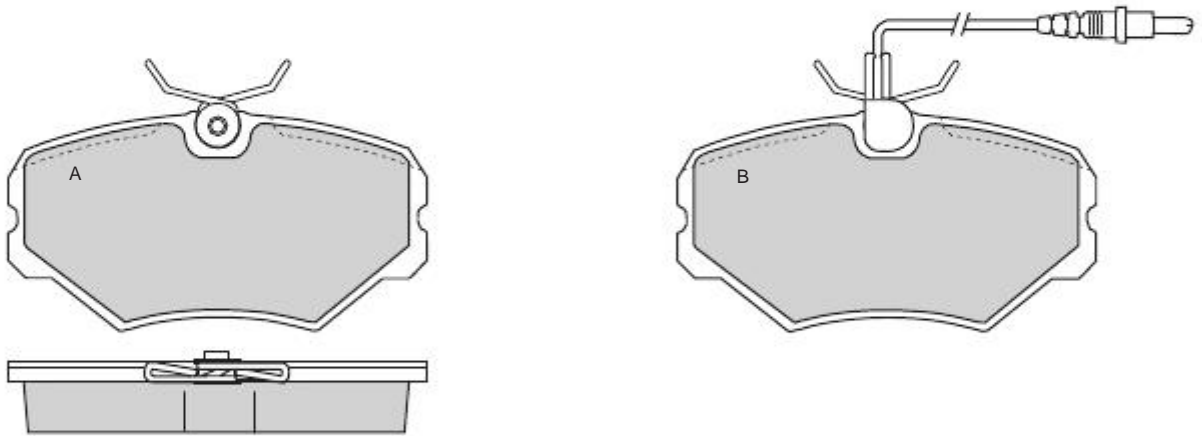



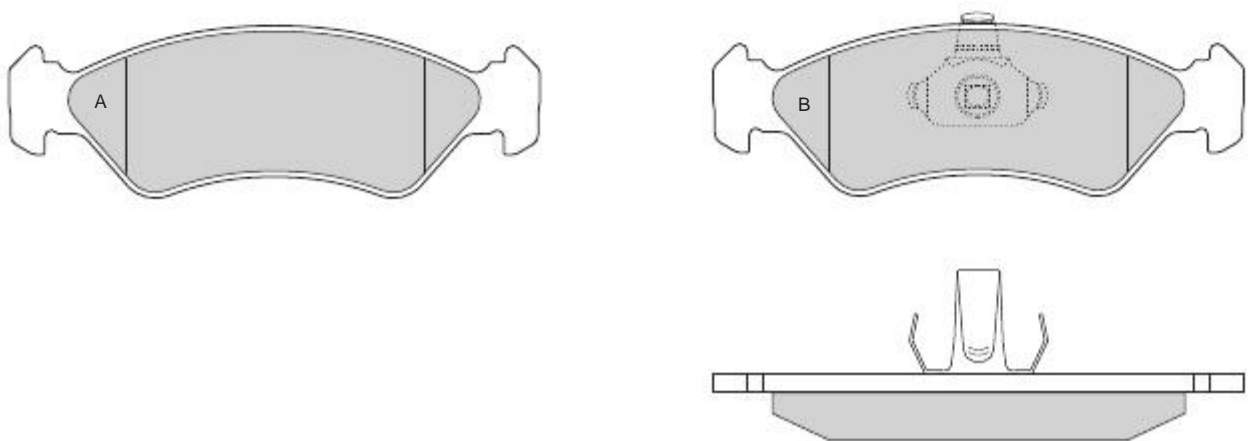

0670	PEUGEOT	GIRLING	X	110	57,3	19	2A-2B	2	250
------	---------	---------	---	-----	------	----	-------	---	-----



0671	FORD - MAZDA	ATE	X	140,1	45,5	17,5	2A-2B		
------	--------------	-----	---	-------	------	------	-------	--	--

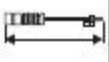

									
0672	SEAT - SKODA VOLKSWAGEN	KELSEY-HAYES		141,8	A 50,5 B 51,2	19,7	2A-2B		

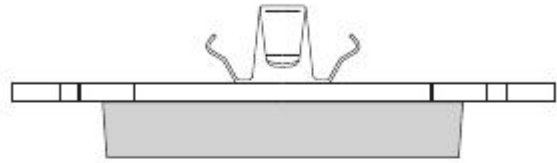
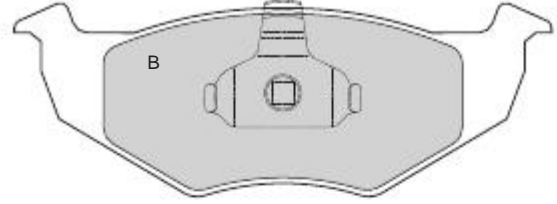
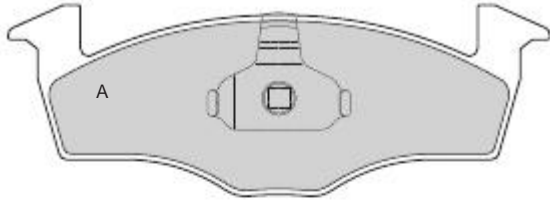



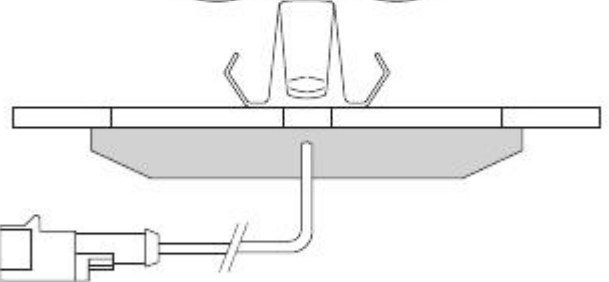
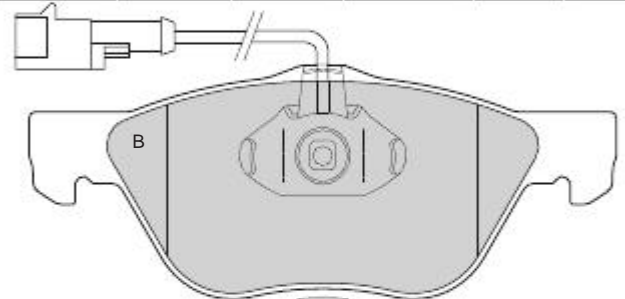
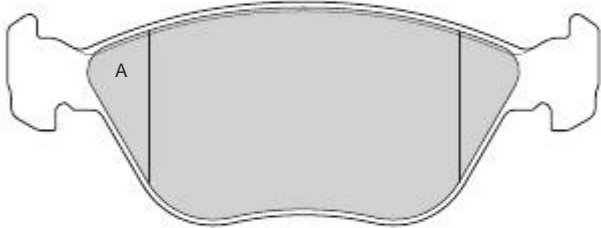



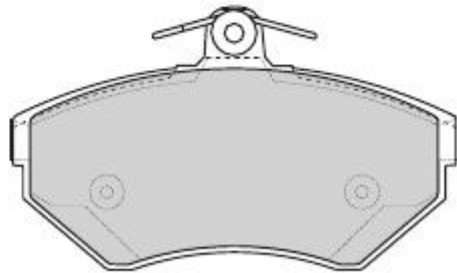



0673	ALFA ROMEO - FIAT LANCIA	ATE	X	155,1	A 59 B 61,8	19	2A-2B	2	220
-------------	-----------------------------	-----	---	-------	----------------	----	-------	---	-----



0674	AUDI - VOLKSWAGEN	GIRLING	X	118,9	69,5	19,6	4		
-------------	-------------------	---------	---	-------	------	------	---	--	--



									
0675	FORD	ATE	X	151,3	46,6	17,5	2A-2B		

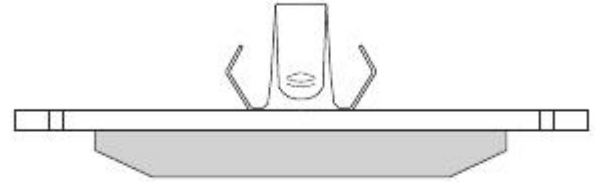
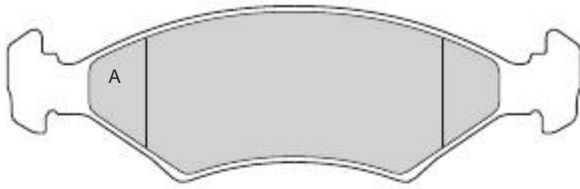



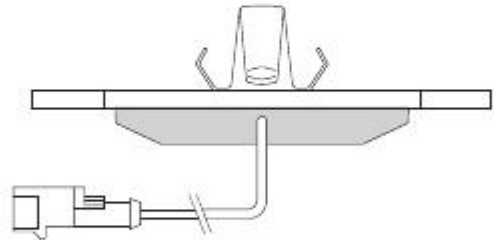
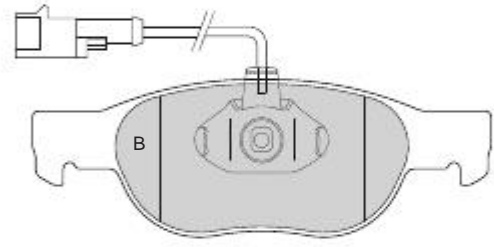



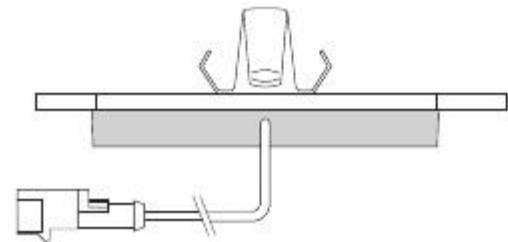
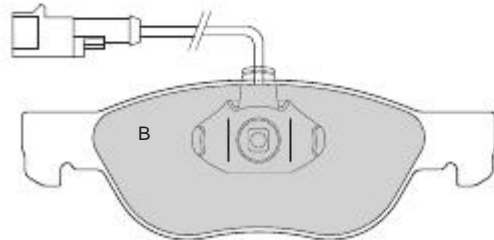

0676	ALFA ROMEO	ATE	X	151,3	52	17,5	2A-2B	2	220
-------------	------------	-----	---	-------	----	------	-------	---	-----



0677	ALFA ROMEO - FIAT	ATE	X	156,3	52,6	17,5	2A-2B	2	220
-------------	-------------------	-----	---	-------	------	------	-------	---	-----

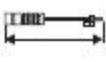

									
0678	CITROEN - FIAT - PEUGEOT	BENDIX	X	139,9	68,8	18,5	2A-2B	2	280

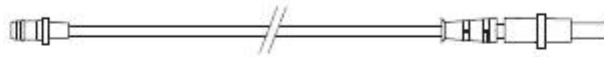
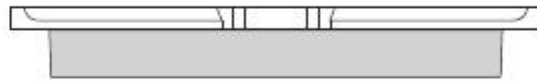



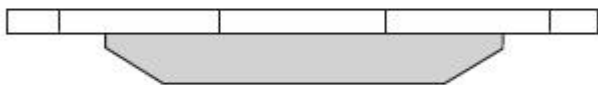
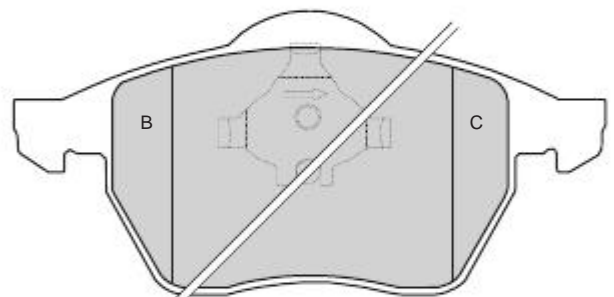
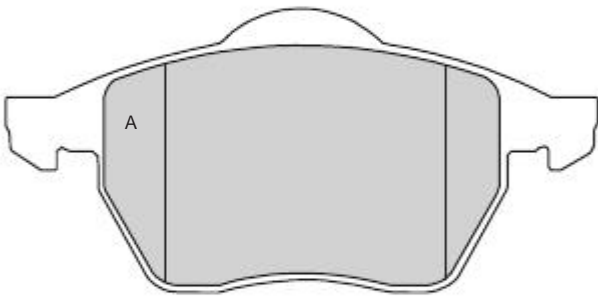





0679	AUDI - FORD - SEAT VOLKSWAGEN	ATE	X	156,4	74,2	A 19,5 B-C 20,5	2A 1B-1C		
------	----------------------------------	-----	---	-------	------	--------------------	-------------	--	--



0680	ALFA ROMEO - LANCIA	GIRLING	X	89,8	49,9	16,4	4		
------	---------------------	---------	---	------	------	------	---	--	--

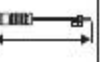

										
0681	MERCEDES - VOLKSWAGEN	PERROT	X	X	164,5	72,8	20	4	2	300

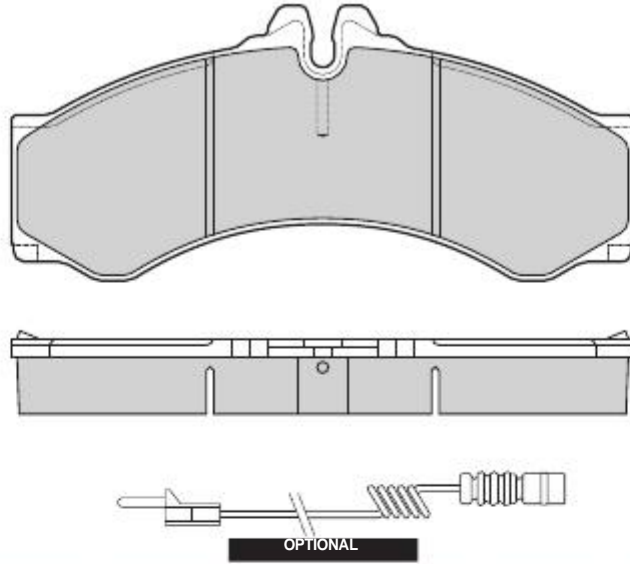



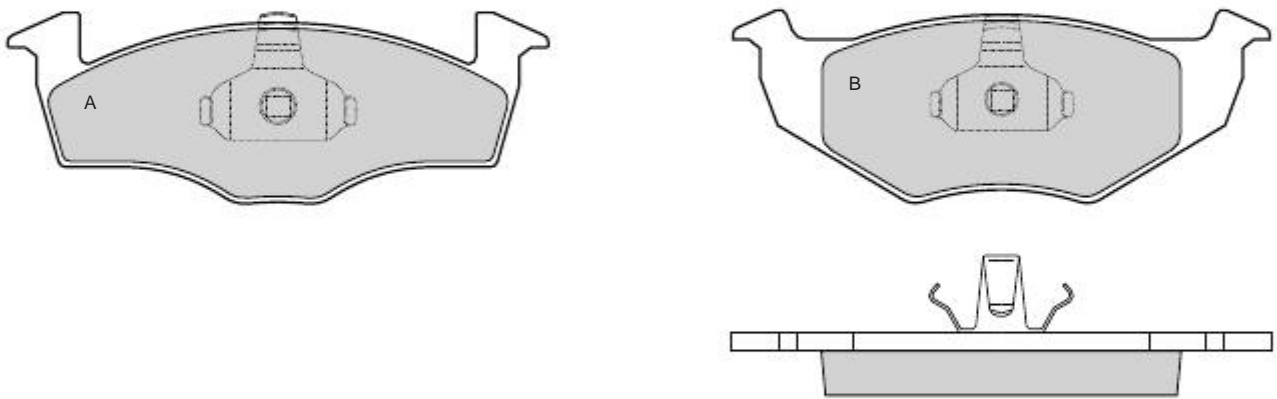



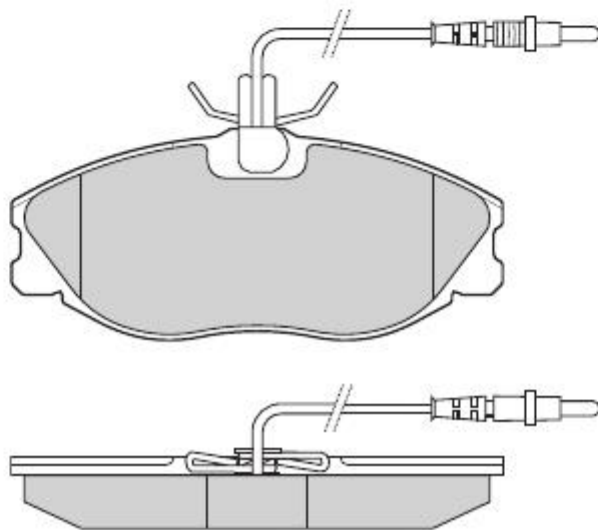

0682	SEAT - SKODA VOLKSWAGEN	KELSEY-HAYES	X		141,8	A 50,5 B 51,2	17,2	2A-2B		
------	----------------------------	--------------	---	--	-------	------------------	------	-------	--	--



0683	PEUGEOT	GIRLING	X		130	56,9	19	4	4	305
------	---------	---------	---	--	-----	------	----	---	---	-----

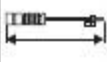

									
0684	SUZUKI	SUMITOMO	X	111,2	48,5	15	4		

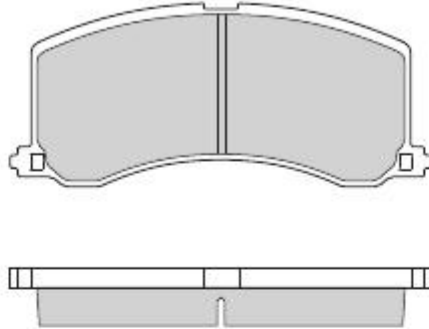



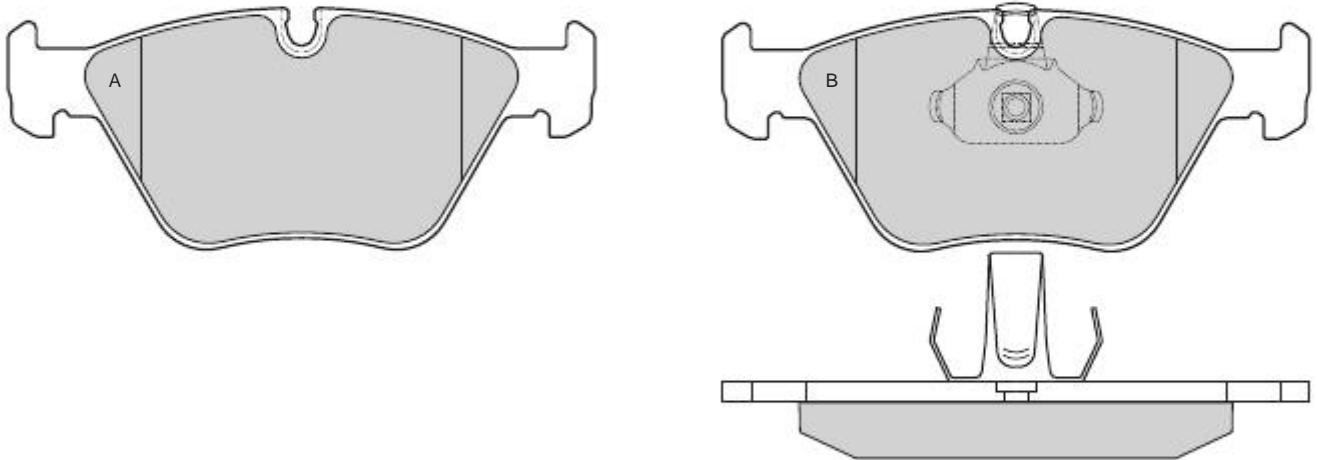



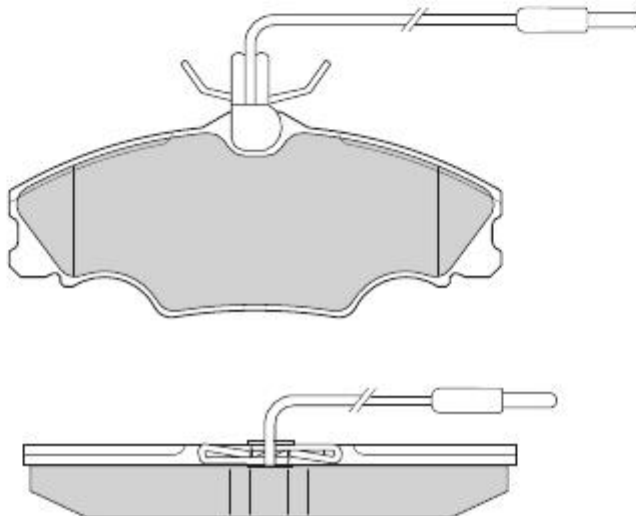



0685	BMW	ATE	X	A 156,4 B 155,1	64,2	20,3	2A-2B		
-------------	-----	-----	---	--------------------	------	------	-------	--	--



0686	PEUGEOT	GIRLING	X	129,85	54,2	19,3	4	4	305
-------------	---------	---------	---	--------	------	------	---	---	-----



									
0687	MERCEDES - VOLKSWAGEN	ATE	X	156,5	64,9	20,5	2A-2B		

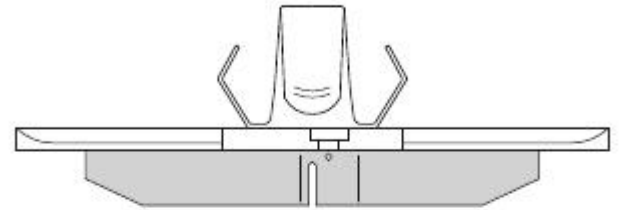
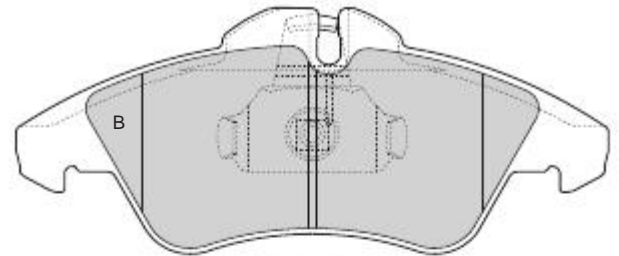
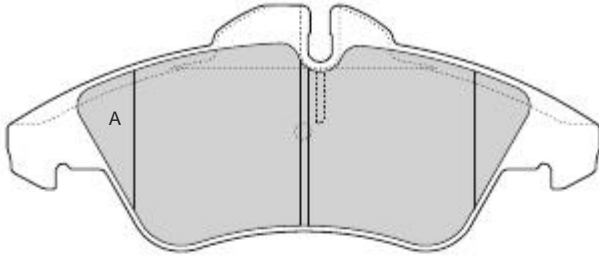



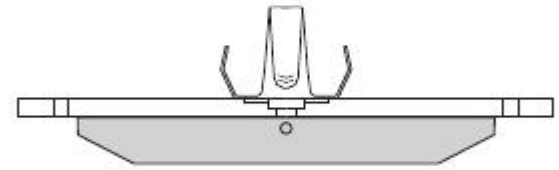
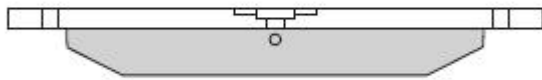
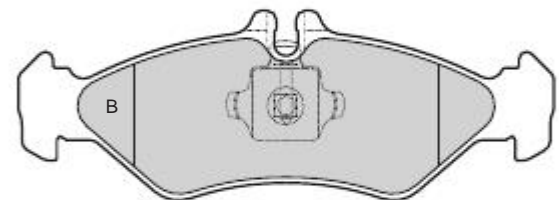
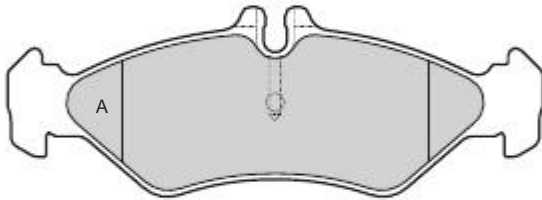



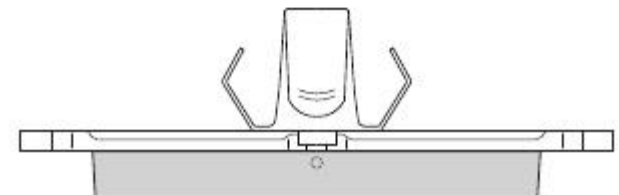
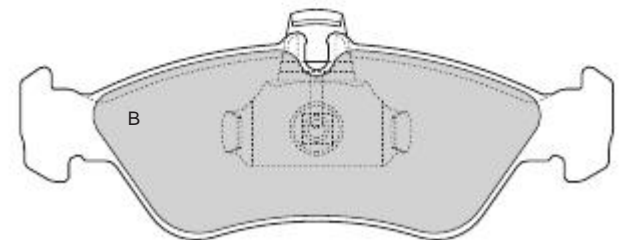
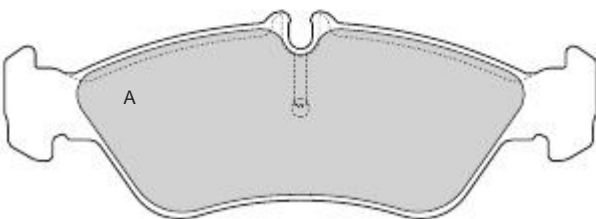

0688	MERCEDES - VOLKSWAGEN	ATE	X	141,4	50,2	17	2A-2B		
-------------	-----------------------	-----	---	-------	------	----	-------	--	--



0689	MERCEDES - VOLKSWAGEN	ATE	X	156,4	54,8	18	2A-2B		
-------------	-----------------------	-----	---	-------	------	----	-------	--	--

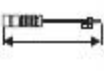

									
0690	NISSAN	AKEBONO	X	99,5	40	15	2A 1B-1C		

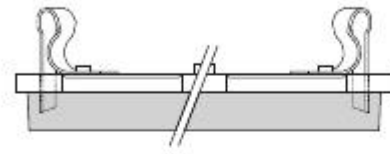
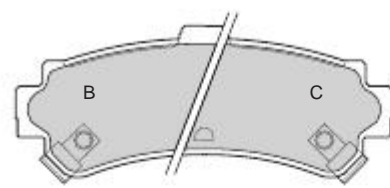



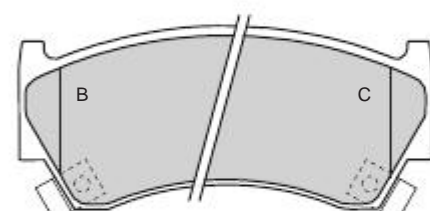
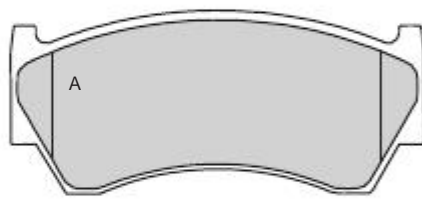



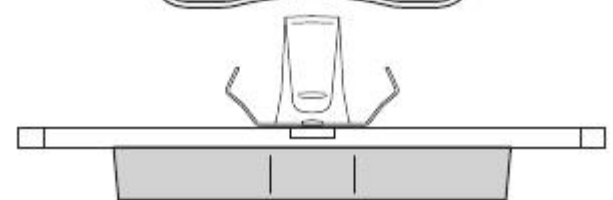
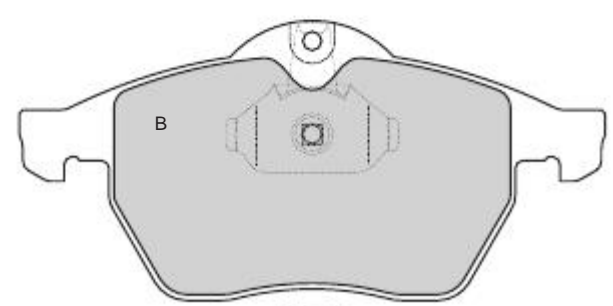
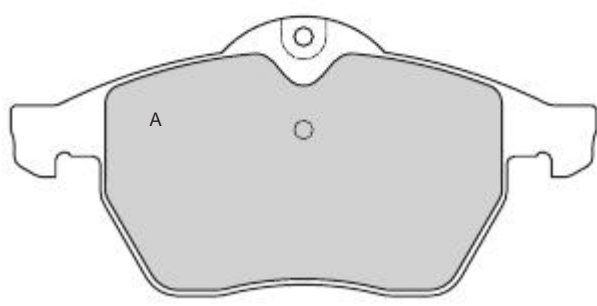

0691	NISSAN	SUMITOMO	X	108,5	48	15,5	2A 1B-1C		
-------------	--------	----------	---	-------	----	------	-------------	--	--



0692	OPEL - SAAB - VAUXHALL	ATE	X	155,3	74	19,5	2A-2B		
-------------	------------------------	-----	---	-------	----	------	-------	--	--

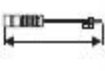

									
0693	FIAT - FSO	GIRLING	X	89,9	63,4	17	2A-2B	2	270

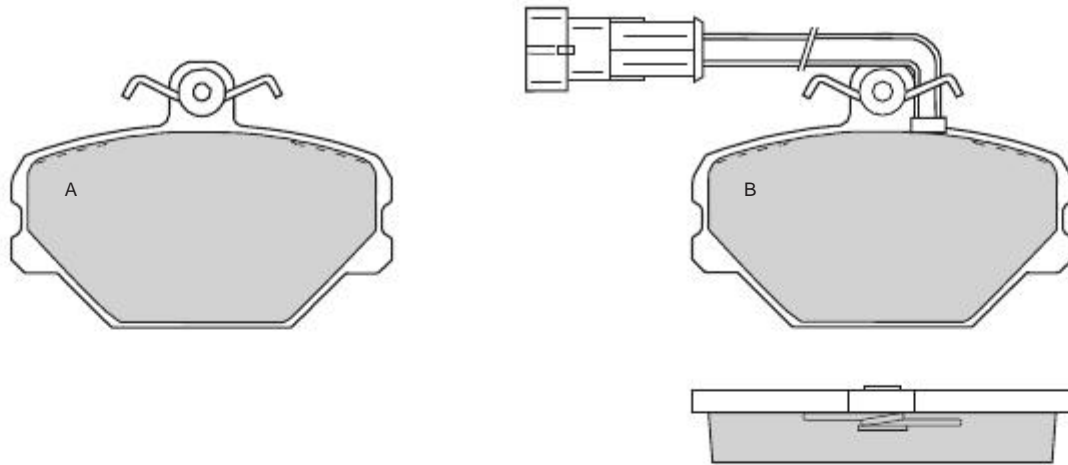



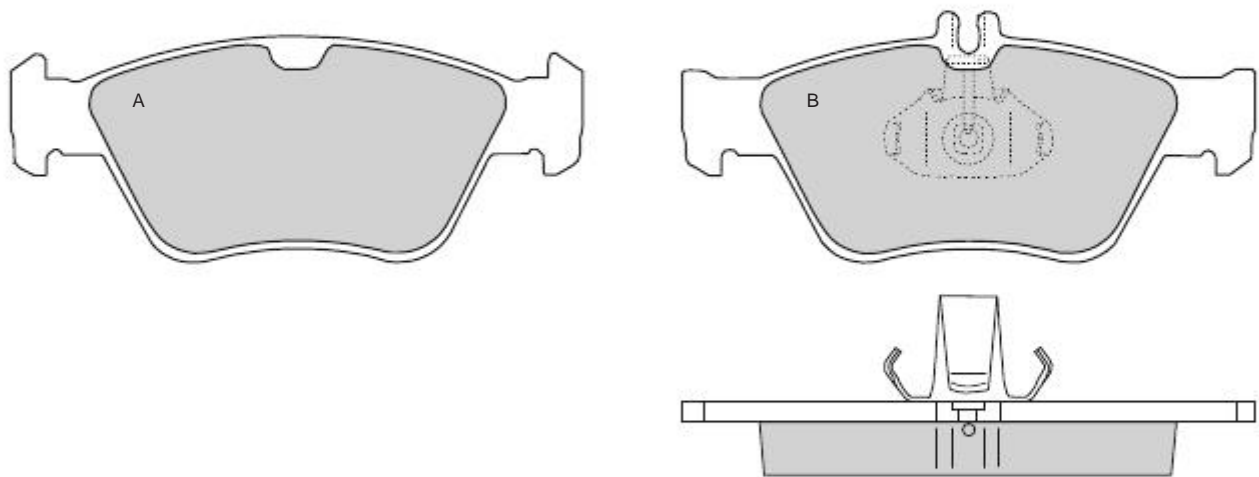



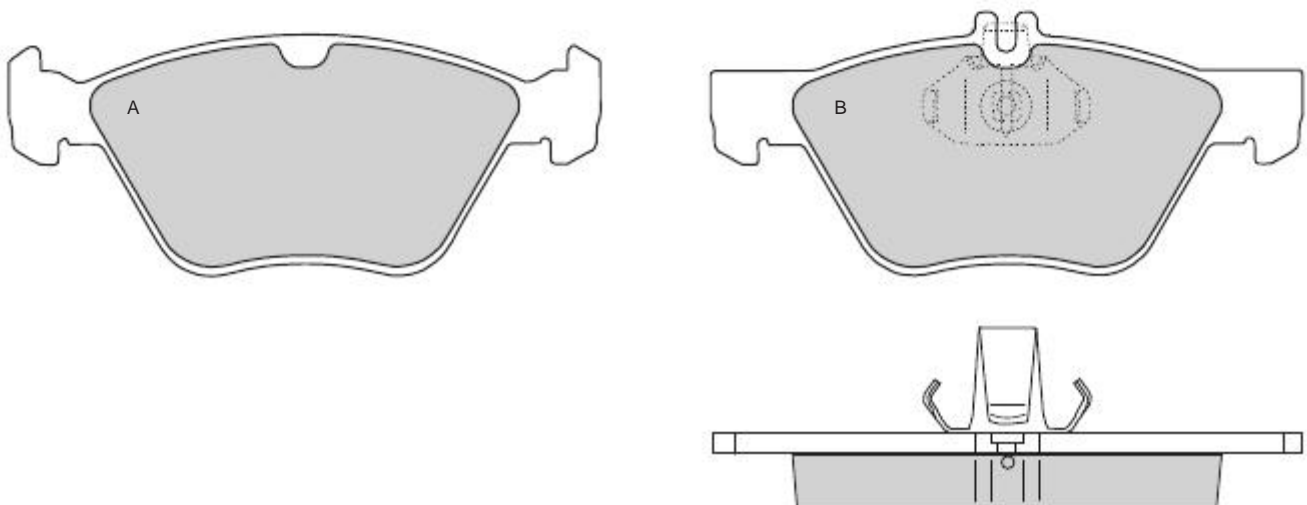



0694	MERCEDES	ATE	X	151,4	A 61 B 66,2	19,5	2A-2B		
------	----------	-----	---	-------	----------------	------	-------	--	--



0695	MERCEDES	ATE	X	156,4	A 64 B 69,5	20	2A-2B		
------	----------	-----	---	-------	----------------	----	-------	--	--



									
0696	TOYOTA	SUMITOMO	X	166,6	63,5	18	4		

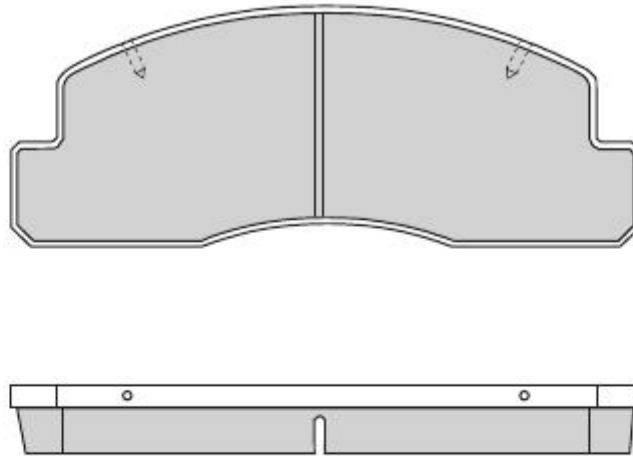



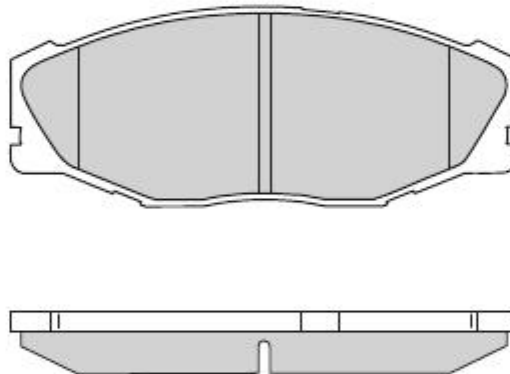



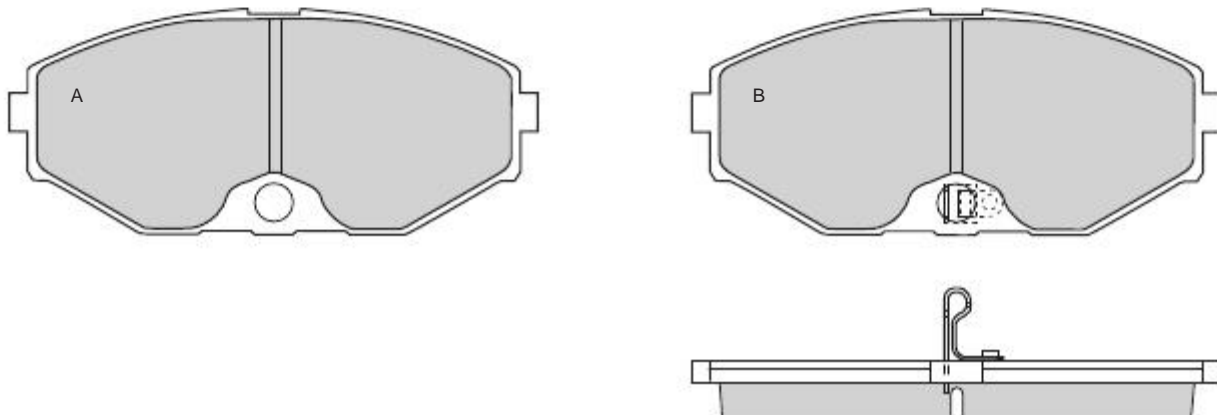



0697	TOYOTA	AKEBONO	X	133	52,5	16,5	4		
-------------	--------	---------	---	-----	------	------	---	--	--



0698	NISSAN	AKEBONO	X	139,3	59,5	14,8	2A-2B		
-------------	--------	---------	---	-------	------	------	-------	--	--



									
0699	NISSAN	SUMITOMO	X	105,2	47	16,3	2A 1B-1C		

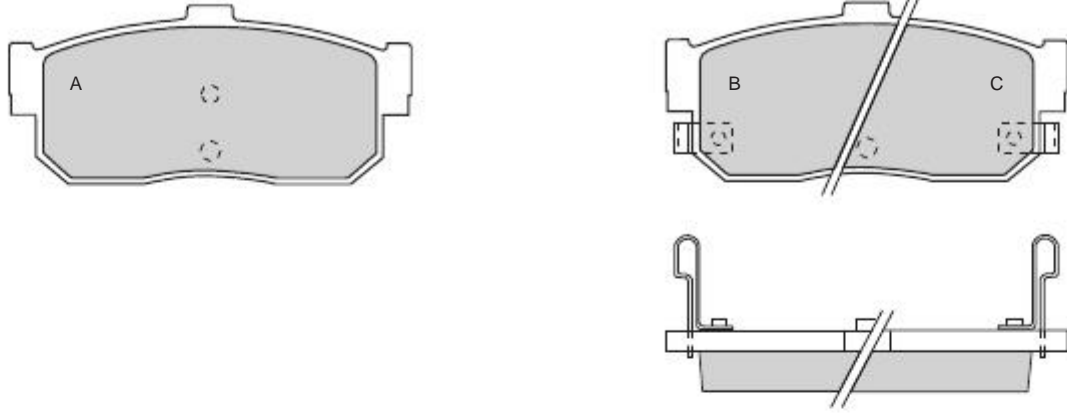



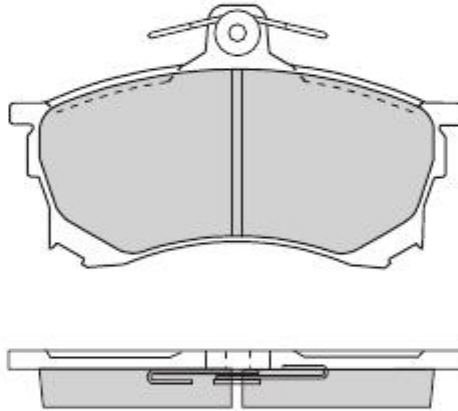



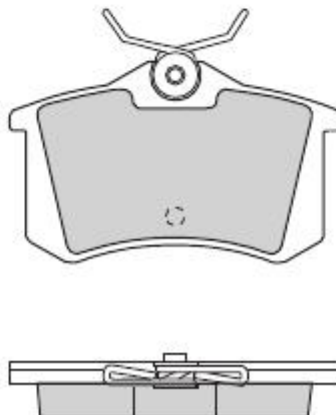



0700	MITSUBISHI	GIRLING	X	119,2	68,5	15	4		
------	------------	---------	---	-------	------	----	---	--	--



0701	LANCIA	GIRLING	X	87	52,9	14,5	4		
------	--------	---------	---	----	------	------	---	--	--



									
0702	MITSUBISHI - VOLVO	GIRLING	X	130	72.8	15.1	4		

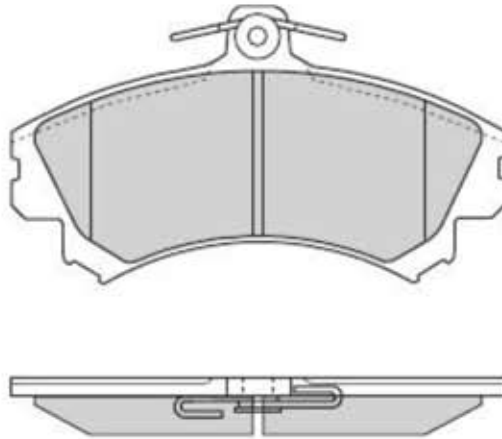



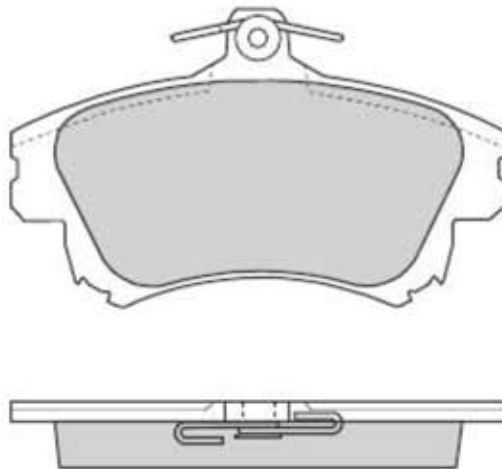



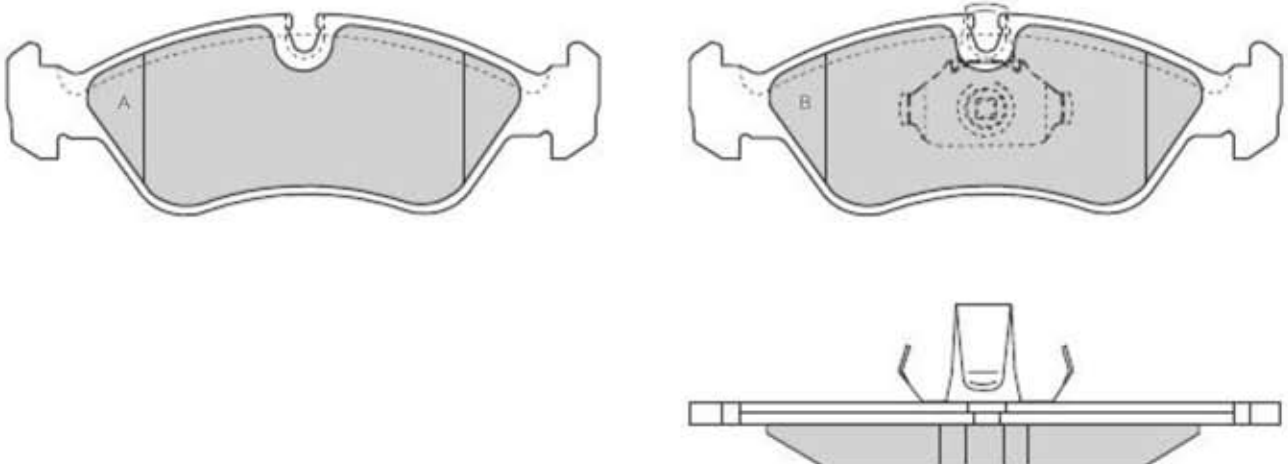



0703	MITSUBISHI - VOLVO	GIRLING	X	130	78	17.3	4		
------	--------------------	---------	---	-----	----	------	---	--	--



0704	OPEL - VAUXHALL	ATE	X	156.3	52.8	17	2A-2B		
------	-----------------	-----	---	-------	------	----	-------	--	--



									
0705	MERCEDES	ATE	X	63.8	57.4	16.9	2A-2B	2	120

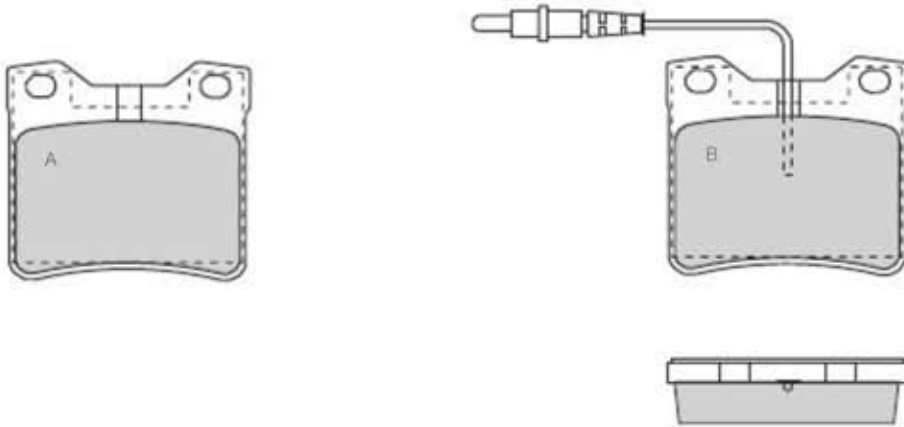



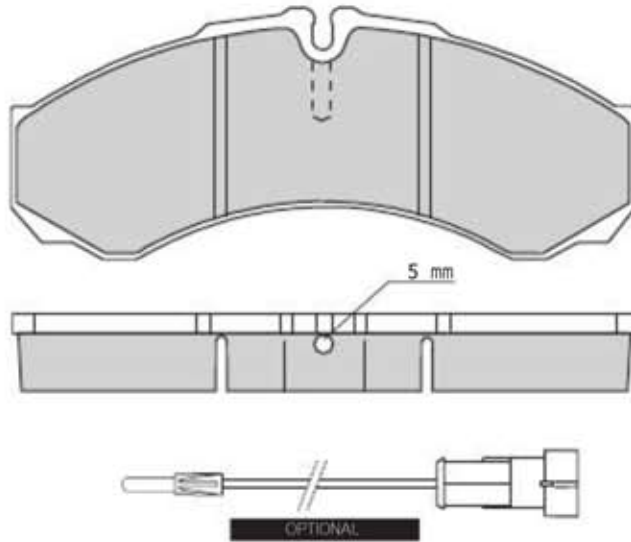



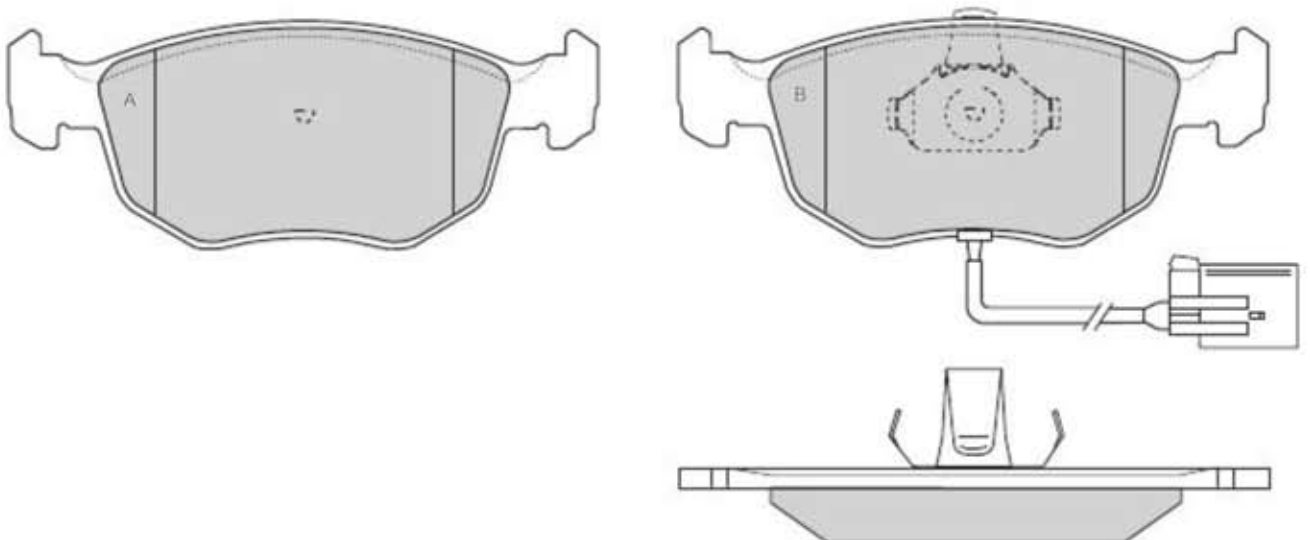



0706	FIAT - IVECO	BREMBO	X	X	164.8	66.5	20.3	4	2	800
------	--------------	--------	---	---	-------	------	------	---	---	-----



0707	FORD	ATE	X	156.4	60.5	19.5	2A-2B	2	240
------	------	-----	---	-------	------	------	-------	---	-----



									
0708	HYUNDAI	GIRLING	X	130	72,6	18	2A 1B-1C		

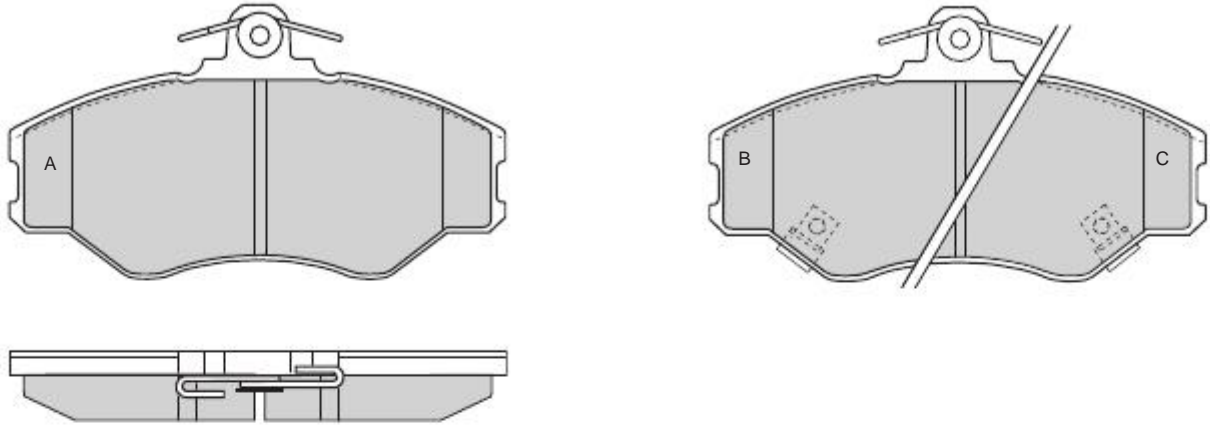



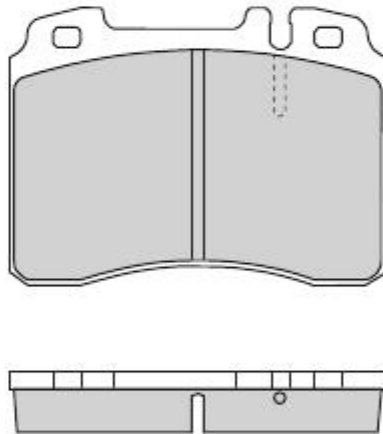



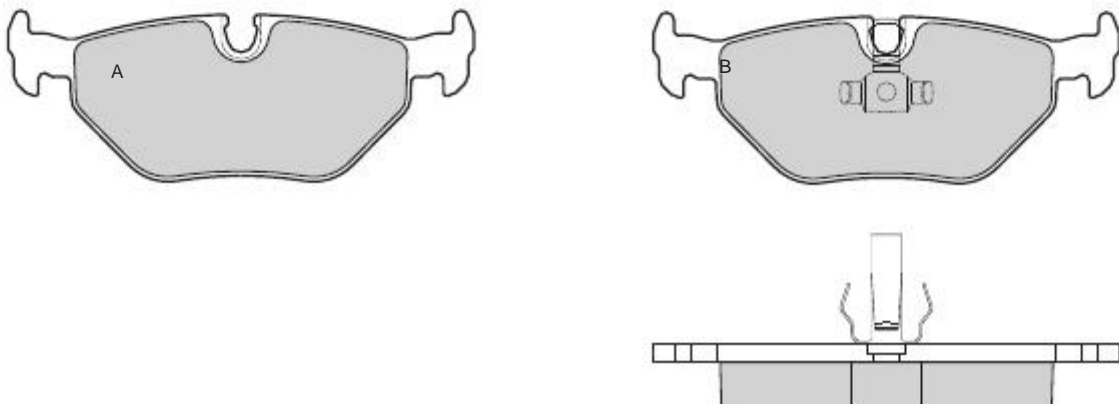



0709	MECEDES	ATE	X	99,5	73,4	16,0	4		
-------------	---------	-----	---	------	------	------	---	--	--



0710	BMW	ATE	X	123,1	44,4	17	2A-2B		
-------------	-----	-----	---	-------	------	----	-------	--	--



									
0711	CITROEN - PEUGEOT	GIRLING	X	130	57	19	4	4	260

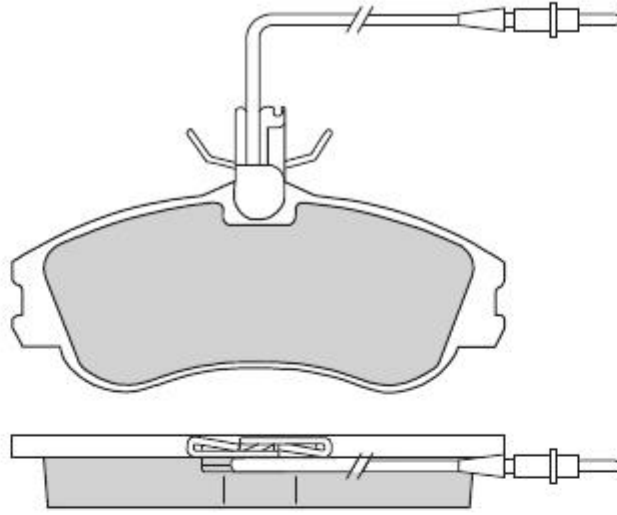



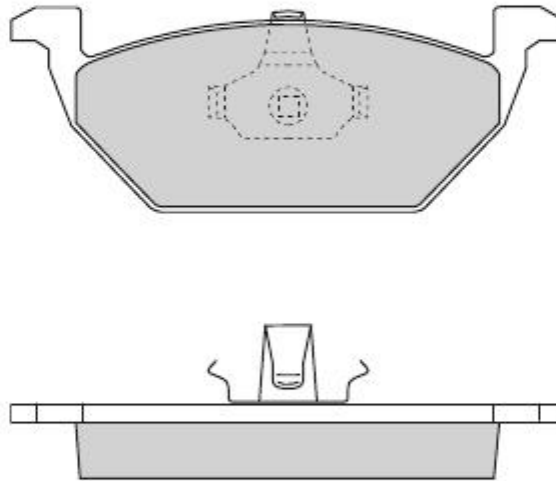



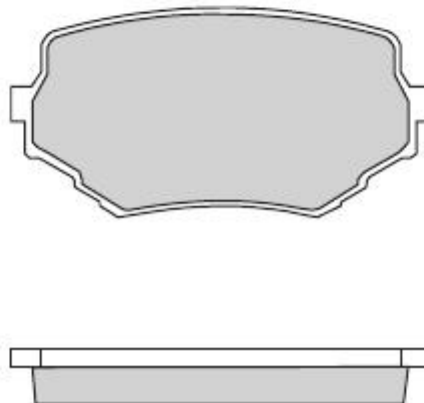

0712	AUDI - SEAT - SKODA VOLKSVAGEN	ATE	X	146	54,7	19,2	4		
-------------	-----------------------------------	-----	---	-----	------	------	---	--	--



0713	SUZUKI	SUMITOMO	X	110,2	55	14,5	4		
-------------	--------	----------	---	-------	----	------	---	--	--

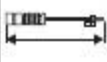

									
0714	LANCIA	BENDIX	X	108,8	47	12	4		

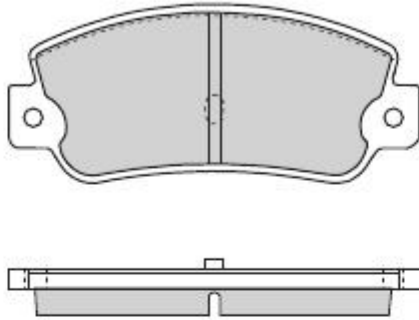



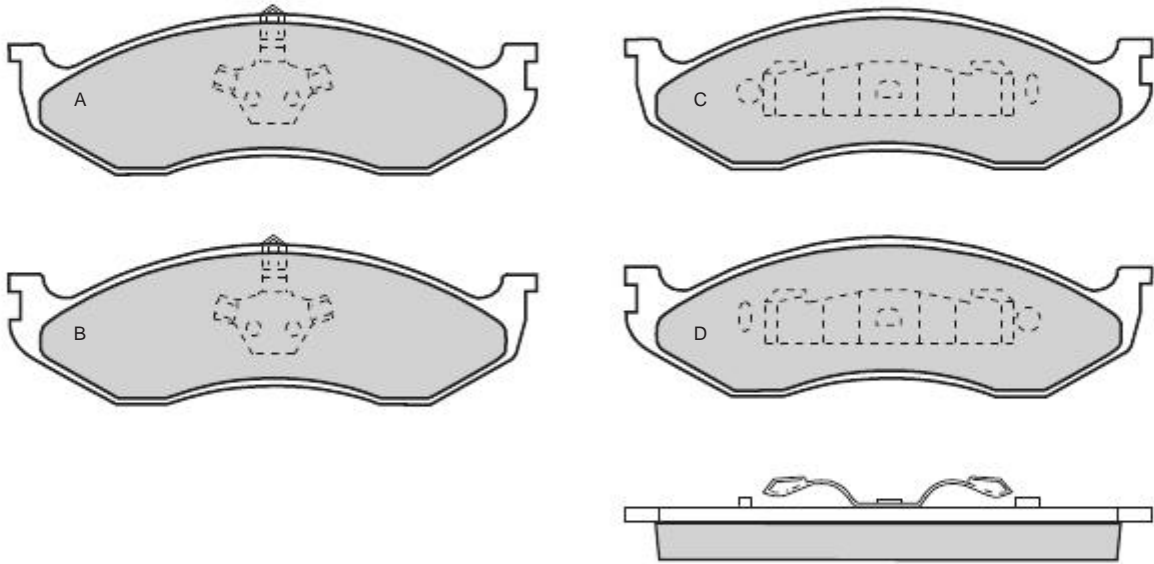



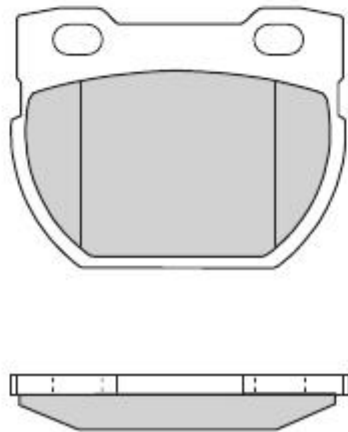



0715	CHRYSLER - JEEP - KIA	KELSEY-HAYES	X	177	55	17,2	1A-1B 1C-1D		
------	-----------------------	--------------	---	-----	----	------	----------------	--	--



0716	LAND ROVER	LOCKHEED	X	88,3	68,8	14,5	4		
------	------------	----------	---	------	------	------	---	--	--



									
0717	LAND ROVER	LOCKHEED	X	126,7	68,5	17	4		

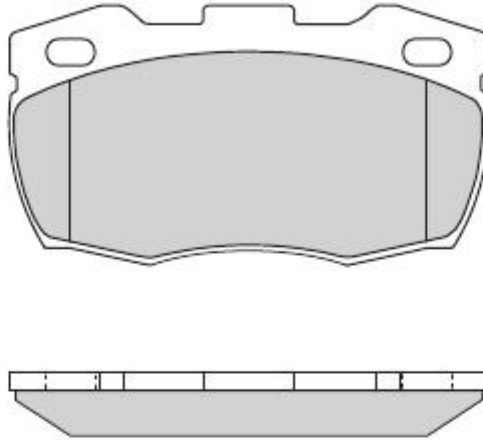



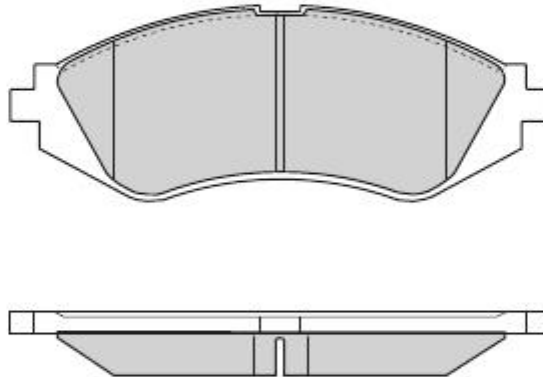



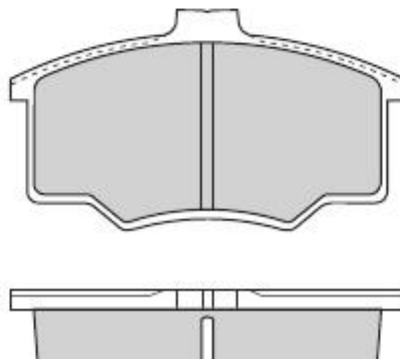



0718	DAEWOO	AKEBONO	X	143	52	17	4		
-------------	--------	---------	---	-----	----	----	---	--	--



0719	FIAT	LUCAS	X	104	58,5	19	4		
-------------	------	-------	---	-----	------	----	---	--	--



									
0720	FIAT	LUCAS	X	104	58,5	16	4		

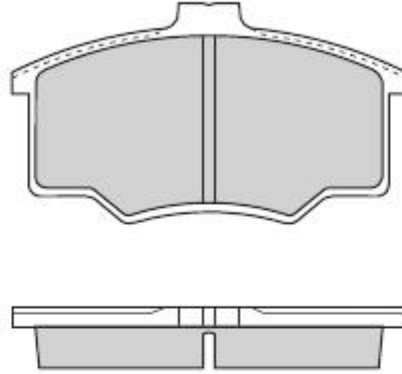



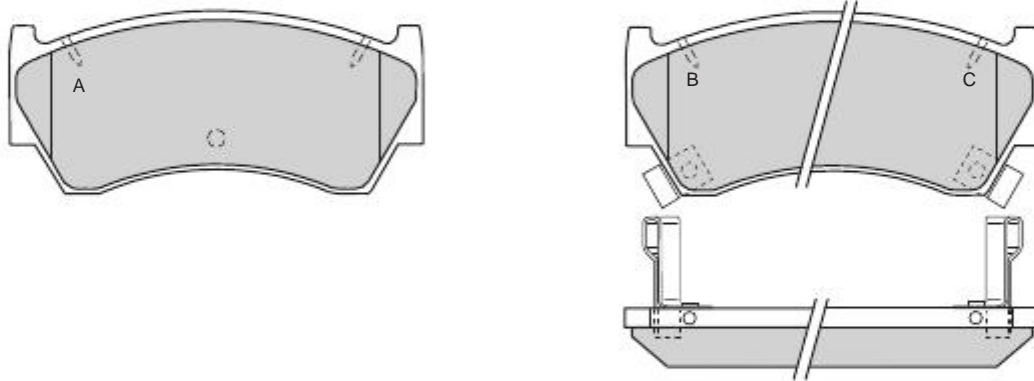



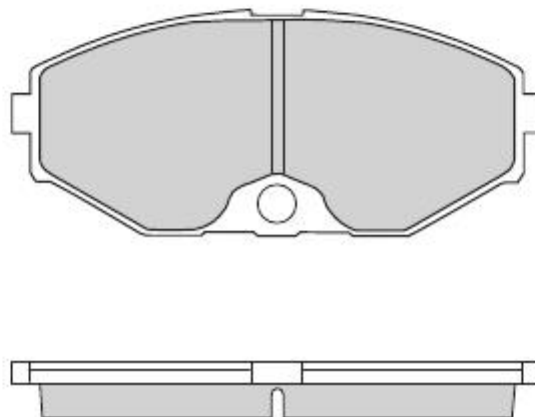



0721	NISSAN	SUMITOMO	X	108,5	48	15,5	2A 1B-1C		225
-------------	--------	----------	---	-------	----	------	-------------	--	-----



0722	NISSAN	AKEBONO	X	139,3	59,5	14,8	4		
-------------	--------	---------	---	-------	------	------	---	--	--



									
0723	VOLKSWAGEN	ATE	X	156,4	68,5	20,6	2A-2B		

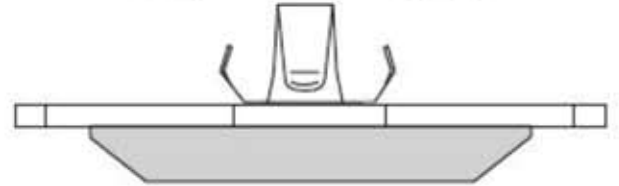
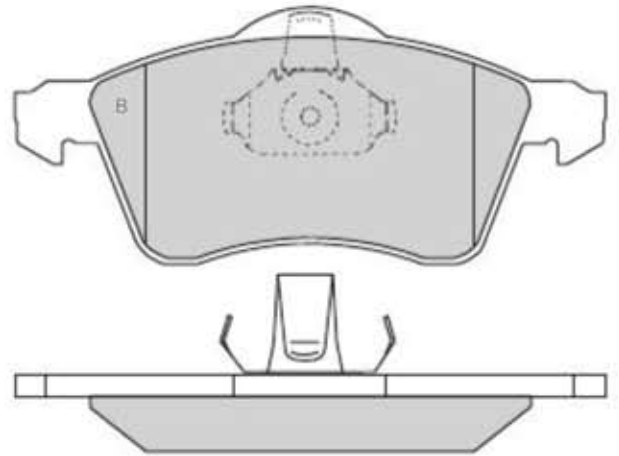
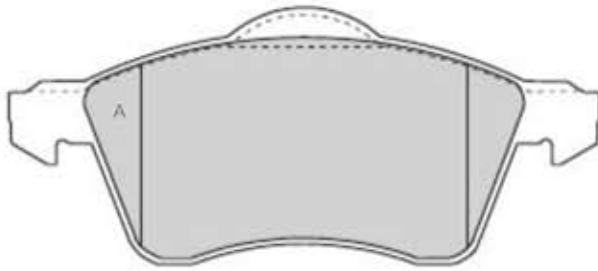







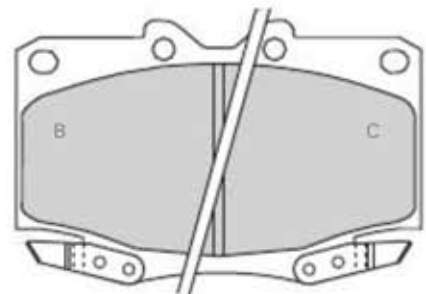
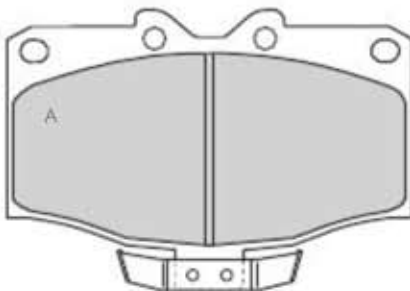

0724	VOLKSWAGEN	GIRLING	X	94,9	57,5	17	4		
------	------------	---------	---	------	------	----	---	--	--



0725	TOYOTA	SUMITOMO	X	107,1	A 74,5 B-C 70,1	15	2A 1B-1C		
------	--------	----------	---	-------	--------------------	----	-------------	--	--

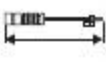

									
0726	NISSAN	SUMITOMO	X	151,3	48,8	17	4		

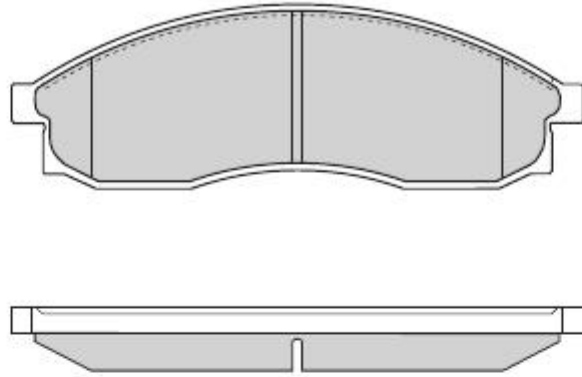



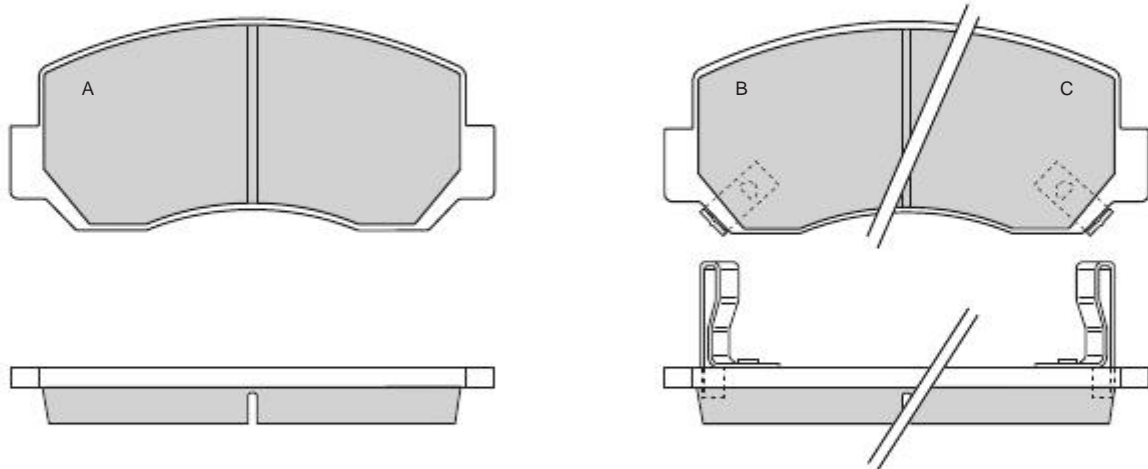



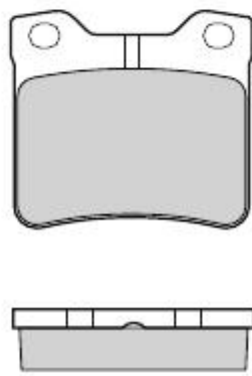

0727	ASIA MOTORS	SUMITOMO	X	127,9	56,2	14,7	2A 1B-1C		
-------------	-------------	----------	---	-------	------	------	-------------	--	--



0728	PEUGEOT	ATE	X	63,7	57,4	16	4		
-------------	---------	-----	---	------	------	----	---	--	--

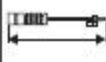

									
0729	CITROEN - PEUGEOT	ATE	X	A 141,5 B 140,25	A 47,6 B 47,45	16,2	2A-2B		

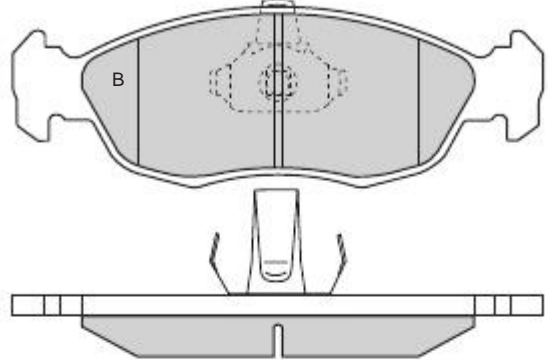
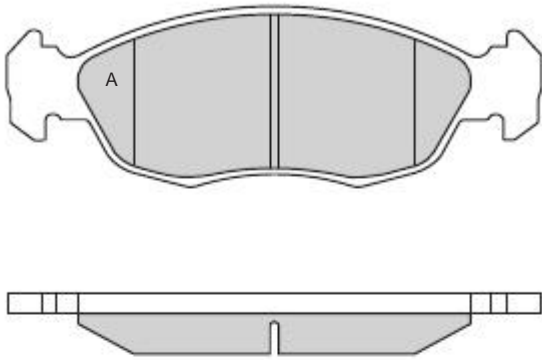



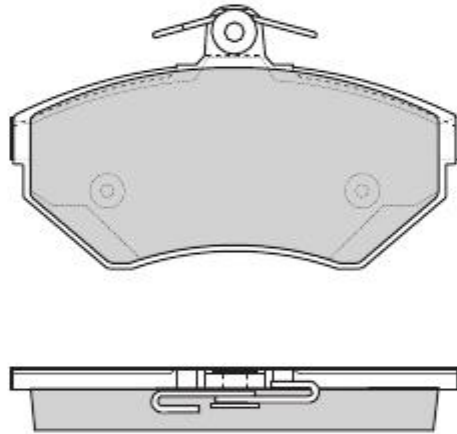



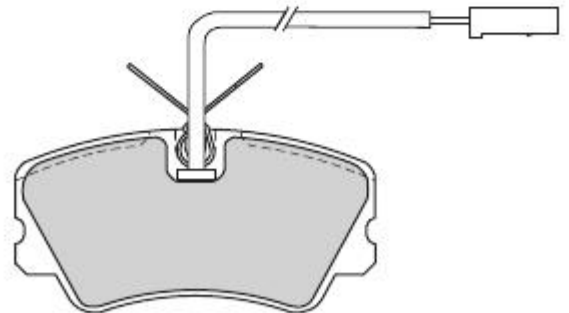
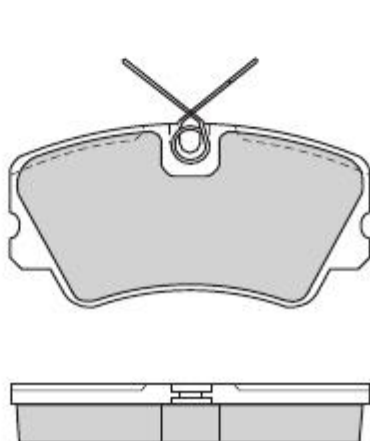

0730	AUDI - SEAT - VOLKSWAGEN	GIRLING	X	118,9	69,5	16	4		
------	--------------------------	---------	---	-------	------	----	---	--	--



0731	ALFA ROMEO	ATE	X	95	48,5	16,5	2A-2B	2	1010
------	------------	-----	---	----	------	------	-------	---	------

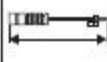

									
0732	MITSUBISHI	SUMITOMO	X	114,2	50	15	4		

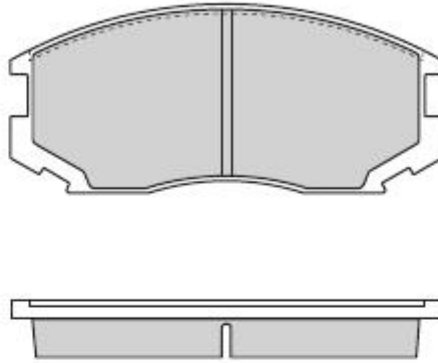



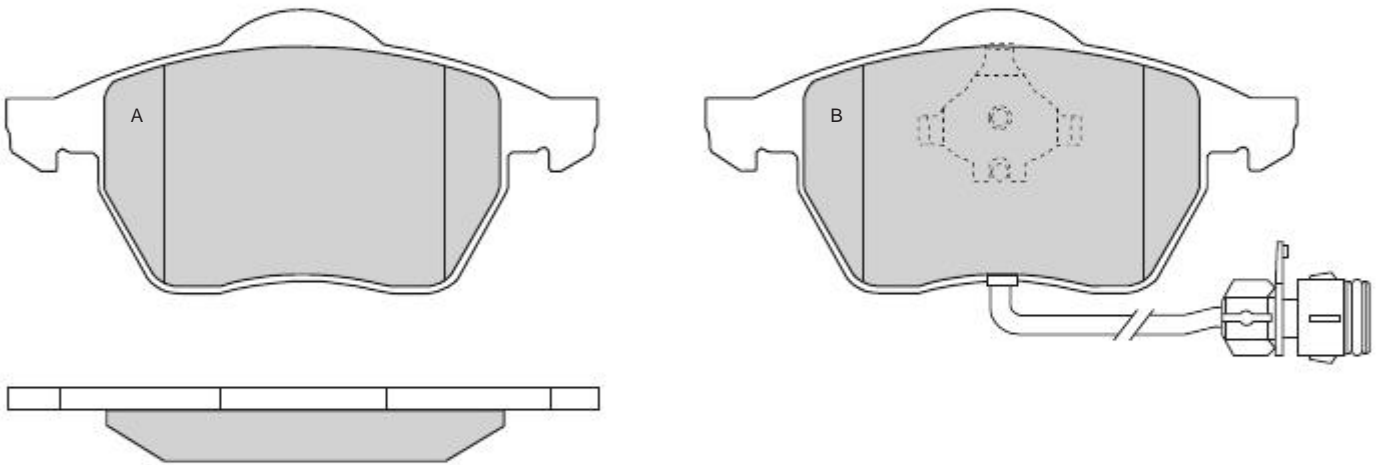



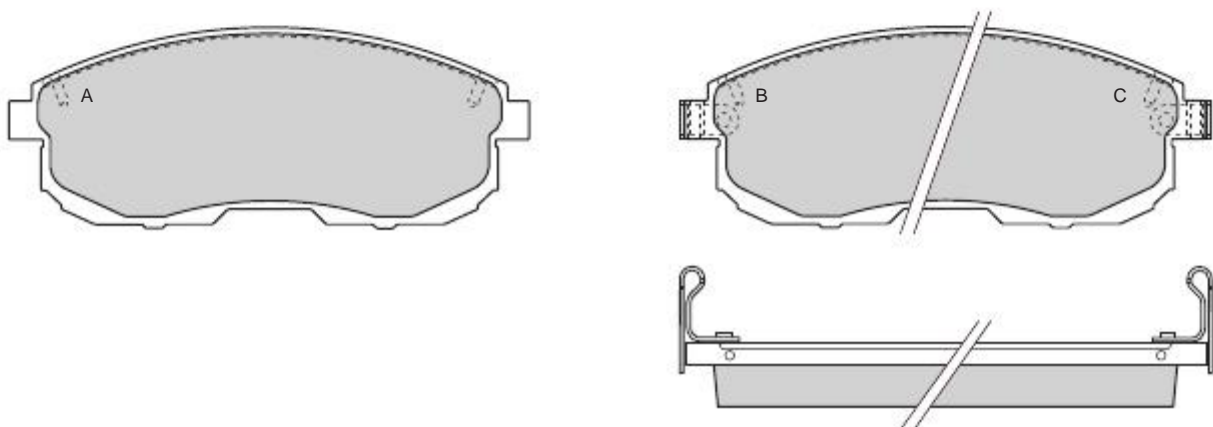



0733	AUDI - VOLKSWAGEN	ATE	X	156,4	74,2	A 19,5 B 20,5	2A-2B	2	200
------	-------------------	-----	---	-------	------	------------------	-------	---	-----



0734	NISSAN	SUMITOMO	X	137,2	53,2	17	2A 1B-1C		
------	--------	----------	---	-------	------	----	-------------	--	--



									
0735	LADA	GIRLING	X	104,4	62	17,5	4	2	170

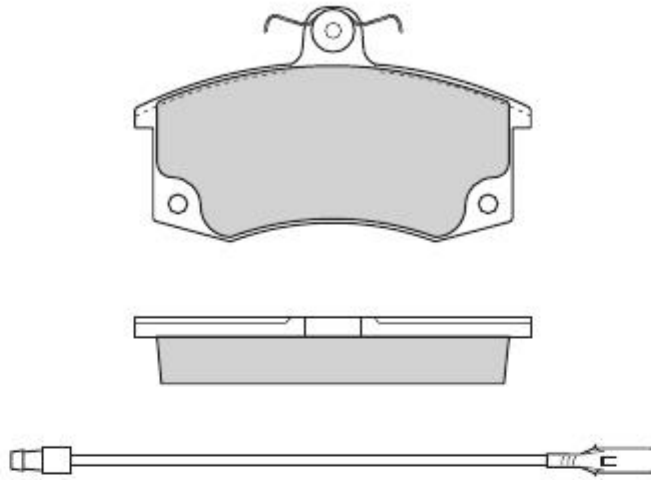



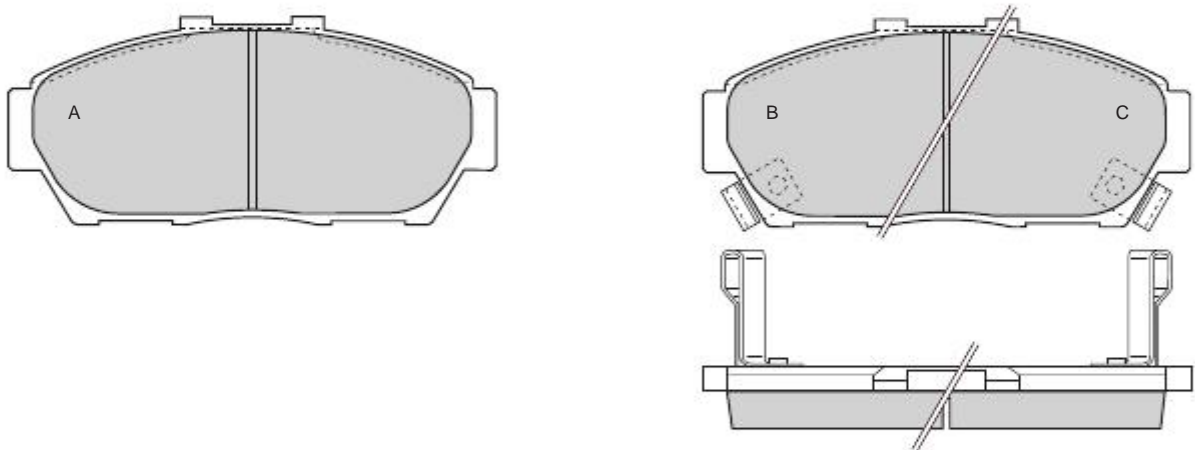



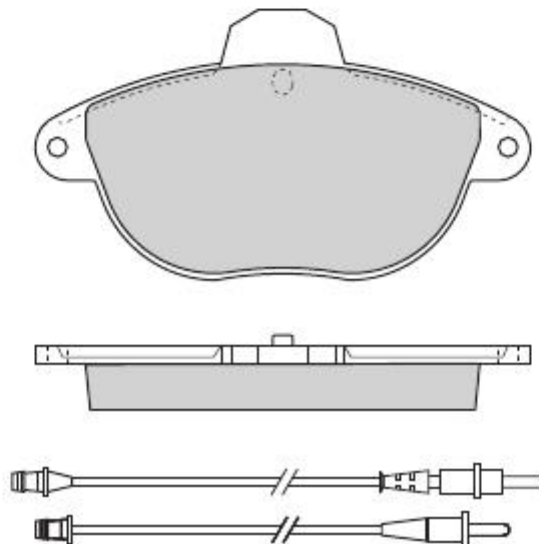

0736	HONDA	AKEBONO	X	129,1	55,1	16,4	2A 1B-1C		
-------------	-------	---------	---	-------	------	------	-------------	--	--



0737	CITROEN	BENDIX	X	130,9	71,4	17	4	2 2	200 350
-------------	---------	--------	---	-------	------	----	---	--------	------------

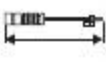

									
0738	SUBARU	BENDIX	X	117,5	53,2	14,8	2A-2B		

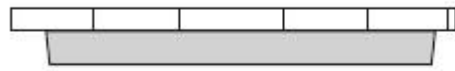
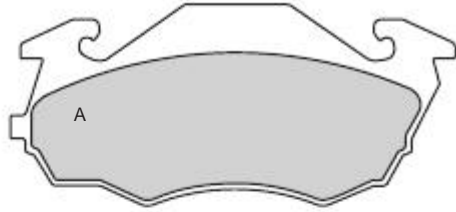



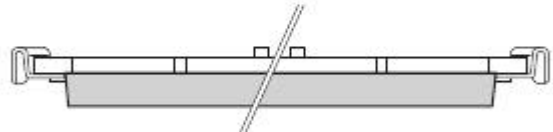
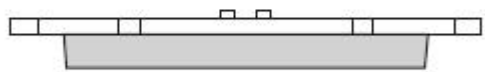
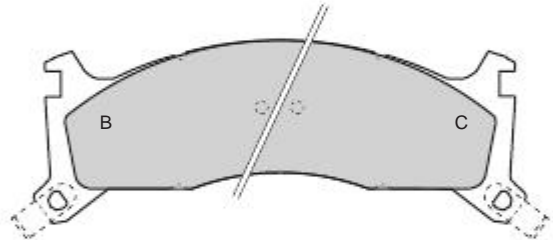
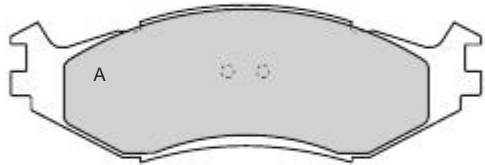



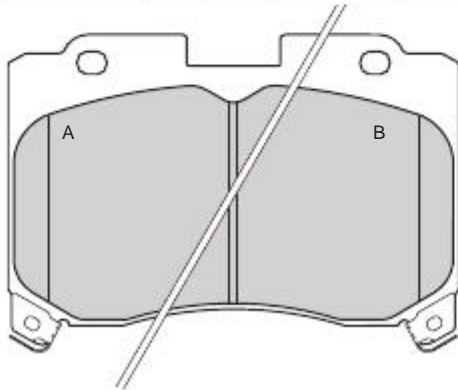

0739	CHRYSLER - DODGE PLYMOUTH	KELSEY-HAYES	X	A 165 B 172,3	A 54,7 B 63,8	A 18 B 16	2A 1 B-1 C		
------	------------------------------	--------------	---	------------------	------------------	--------------	---------------	--	--



0740	TOYOTA	SUMITOMO	X	119,3	82,3	17,8	2A-2B		
------	--------	----------	---	-------	------	------	-------	--	--

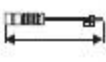

									
0741	TOYOTA	SUMITOMO	X	80,8	68,8	16,5	2A-2B		

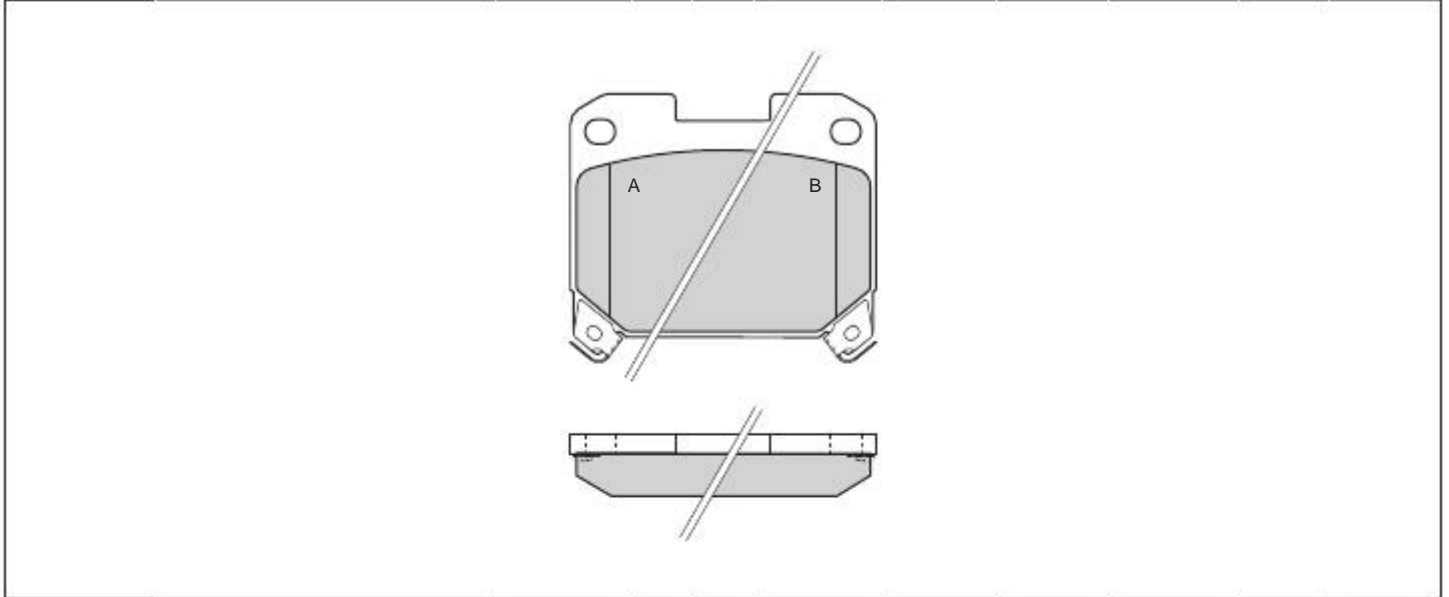



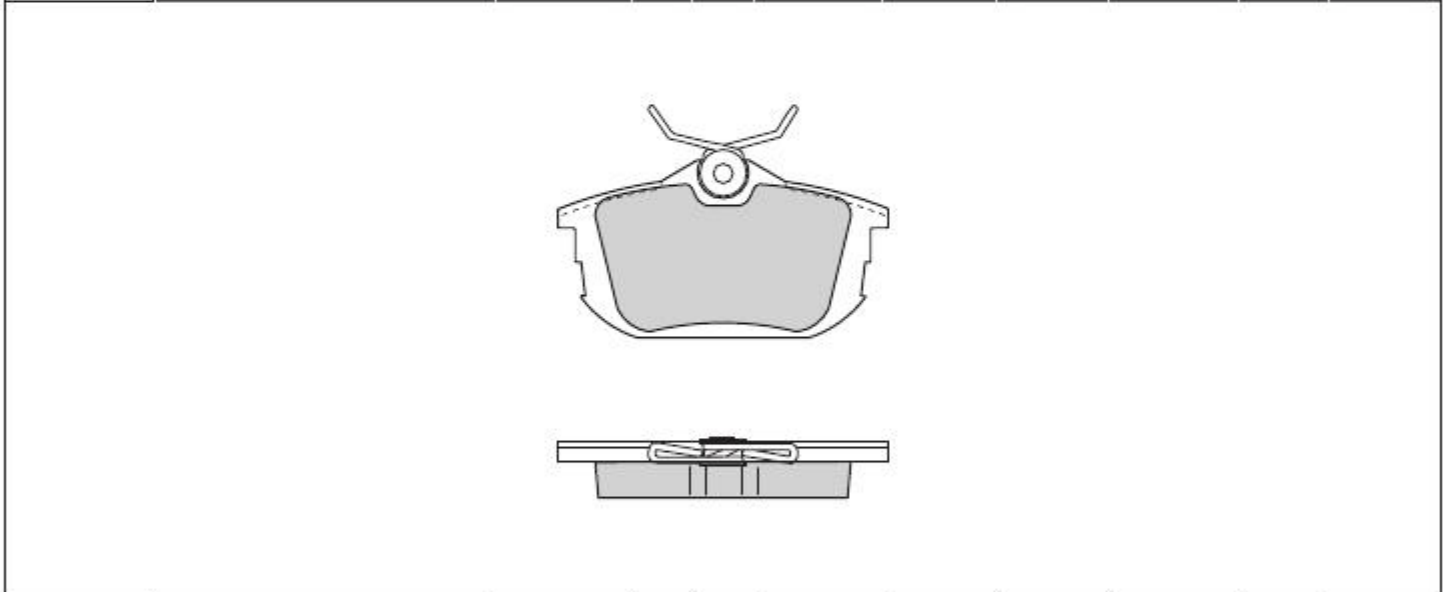



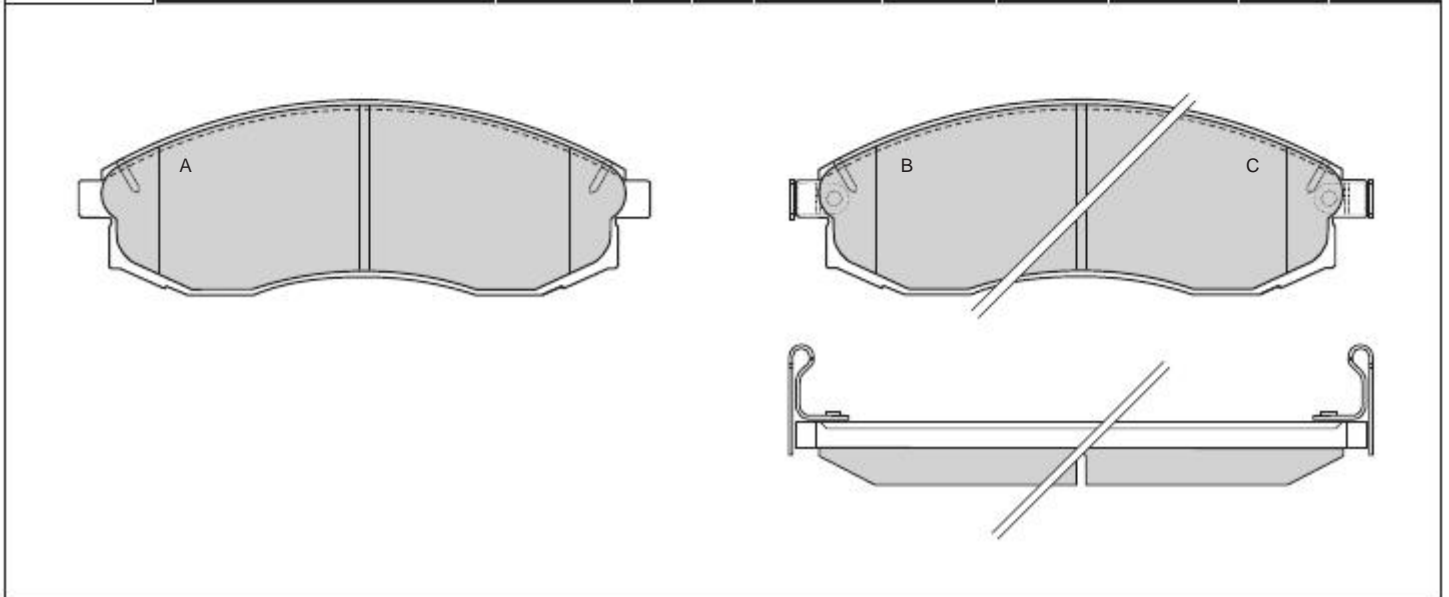

0742	MITSUBISHI - VOLVO	GIRLING	X	87,3	47,5	15	4		
------	--------------------	---------	---	------	------	----	---	--	--



0743	NISSAN	AKEBONO	X	151	51,7	17	2A 1B-1C		
------	--------	---------	---	-----	------	----	-------------	--	--

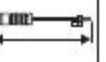

									
0744	IVECO	BREMBO	X	109,7	73,1	18	2A-2B	2	130

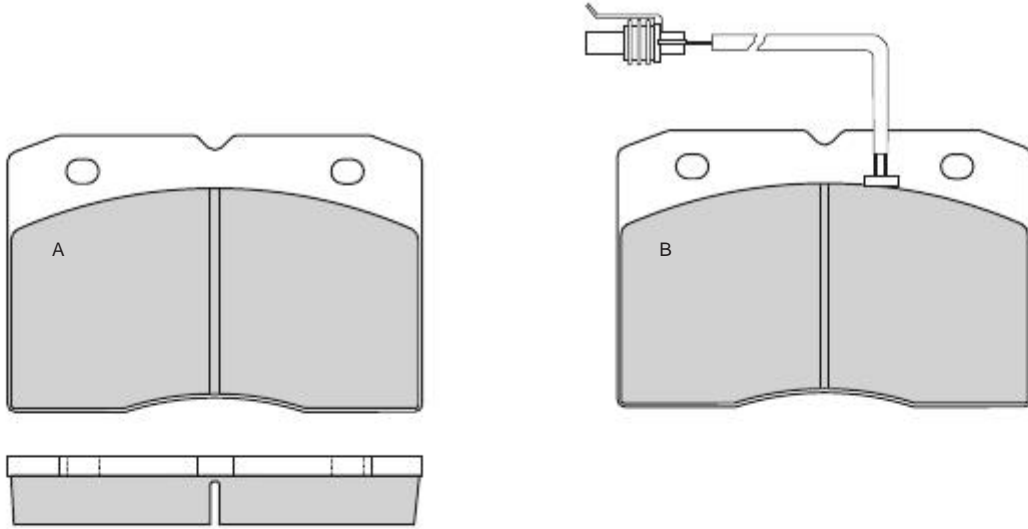



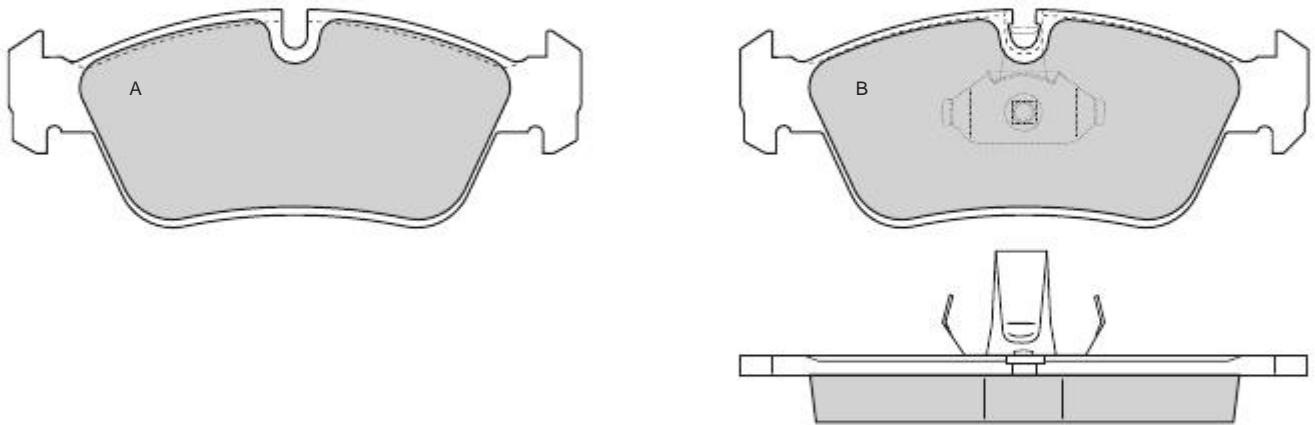



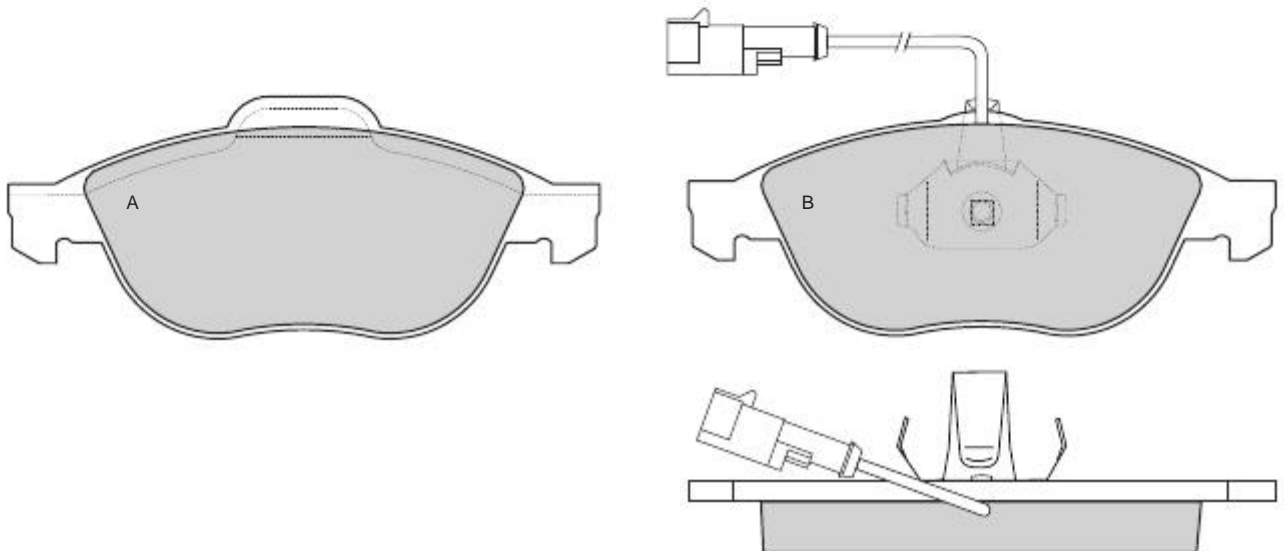

0745	BMW	ATE	X	A 151,4 B 150,2	57,5	17,8	2A-2B		
-------------	-----	-----	---	--------------------	------	------	-------	--	--



0746	ALFA ROMEO	ATE	X	A 156,4 B 155,2	A 63,8 B 59,3	19	2A-2B	2	220
-------------	------------	-----	---	--------------------	------------------	----	-------	---	-----

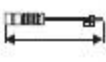

									
0747	JEEP	KELSEY-HAYES	X	141,8	45,5	15	2A 1B-1C		

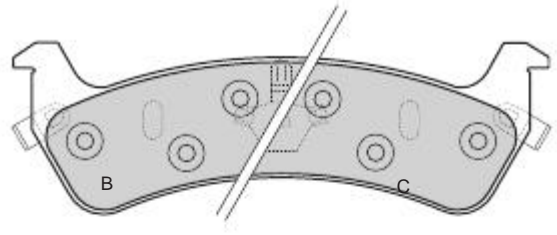
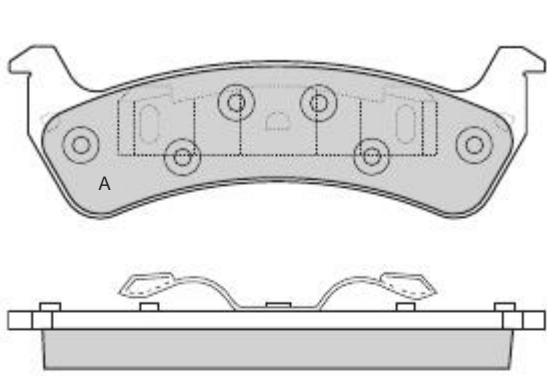



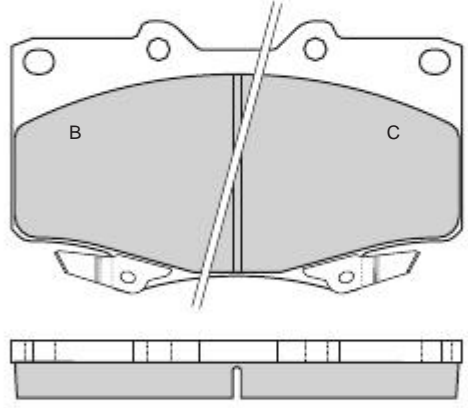
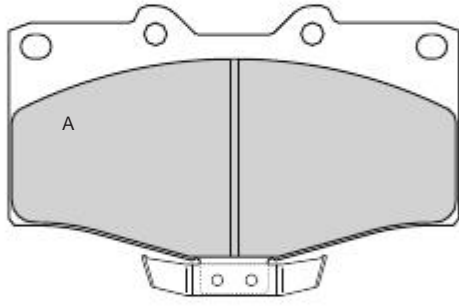



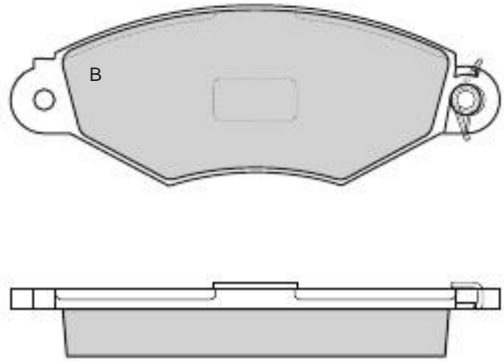

0748	TOYOTA	SUMITOMO	X	119,2	A 76,5 B - C 72	15	2A 1B-1C		
------	--------	----------	---	-------	--------------------	----	-------------	--	--



0749	CITROEN - PEUGEOT RENAULT	BENDIX	X	131	47,6	18	2A-2B		
------	------------------------------	--------	---	-----	------	----	-------	--	--

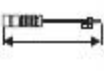

									
0750	HONDA	AKEBONO	X	89	47,5	14,5	2A 1B-1C		

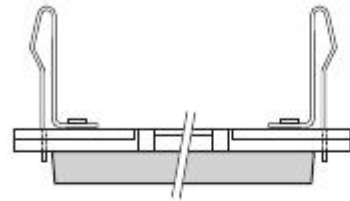
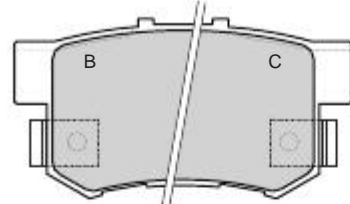
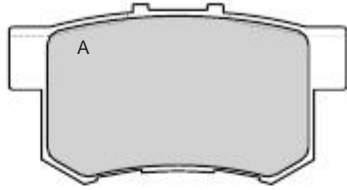



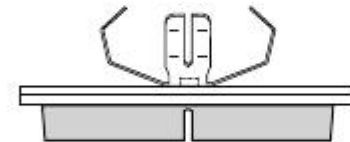
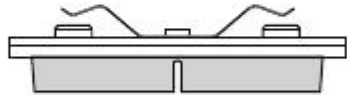
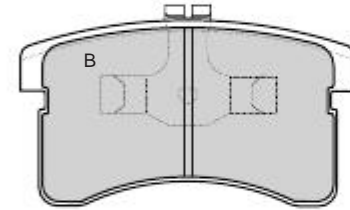
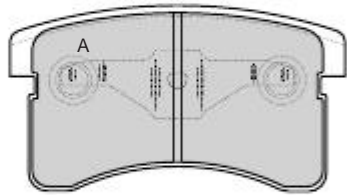



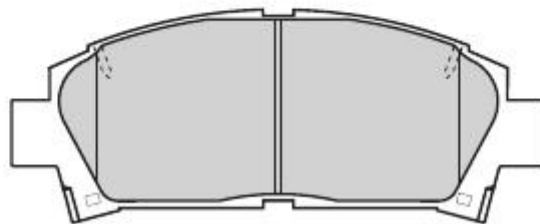



0751	DAIHATSU	SUMITOMO	X	88,8	49,5	A 14 B 14,8	2A-2B		
-------------	----------	----------	---	------	------	----------------	-------	--	--



0752	TOYOTA	AKEBONO	X	141	56,5	15,5	4		
-------------	--------	---------	---	-----	------	------	---	--	--



									
0753	LEXUS	SUMITOMO	X	122	41	5,5	2A-2B		

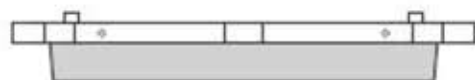



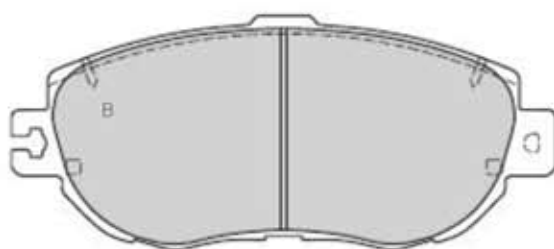
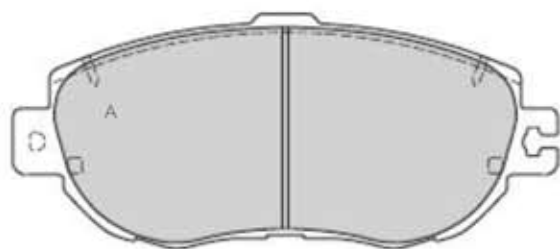



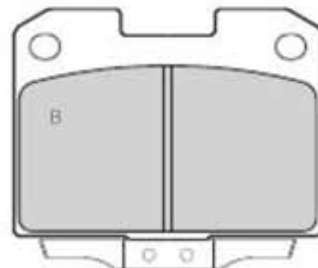
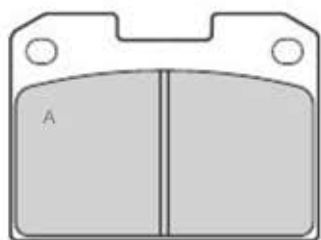



0754	LEXUS	SUMITOMO	X	144	63,8	17,8	2A-2B		
------	-------	----------	---	-----	------	------	-------	--	--



0755	MITSUBISHI	SUMITOMO	X	81,2	A 60 B 69	16	2A-2B		
------	------------	----------	---	------	--------------	----	-------	--	--



									
0756	MAZDA	SUMITOMO	X	128	53,3	15,2	4		

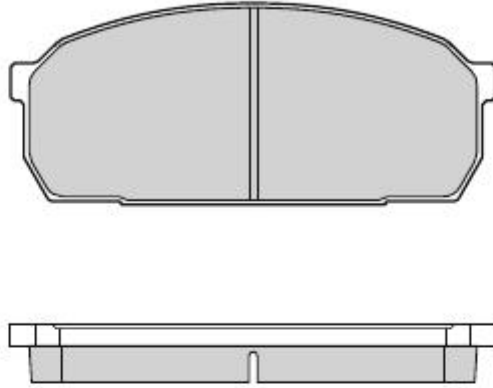



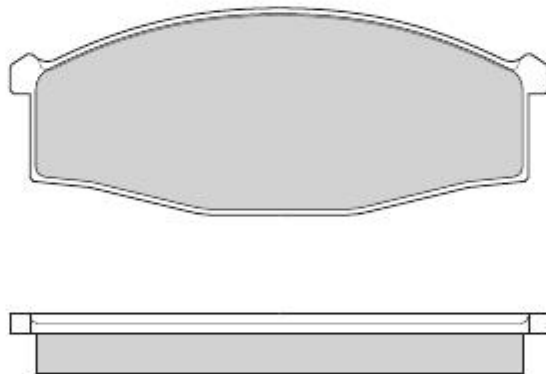



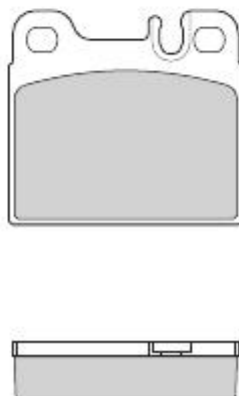

0757	NISSAN	AKEBONO	X	142	60	18	4		
-------------	--------	---------	---	-----	----	----	---	--	--



0758	MERCEDES	ATE	X	61,8	56,5	15,5	4		
-------------	----------	-----	---	------	------	------	---	--	--

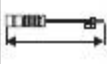

									
0759	MAZDA	AKEBONO	X	102,1	43	12	2A 1B-1C		

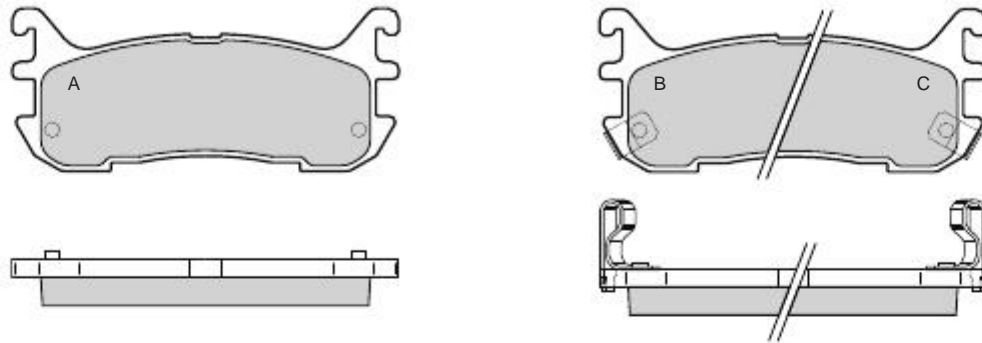



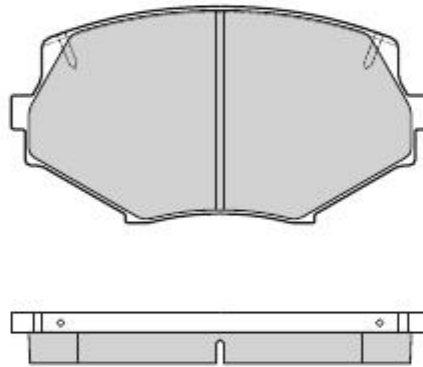



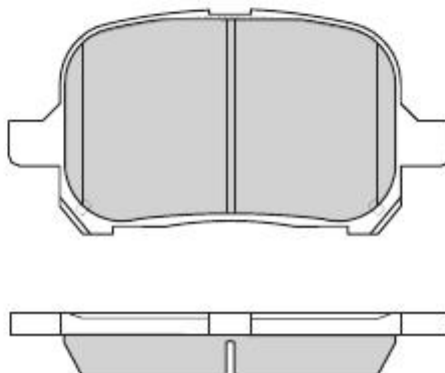



0760	MAZDA	SUMITOMO	X	110,2	57,2	13,2	4		
------	-------	----------	---	-------	------	------	---	--	--



0761	TOYOTA	AKEBONO	X	116,9	59,5	17	4		
------	--------	---------	---	-------	------	----	---	--	--



									
0762	NISSAN	SUMITOMO	X	170	54,8	18	4		

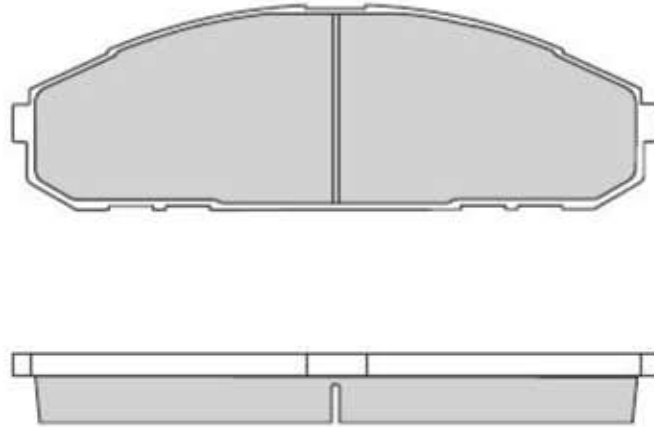



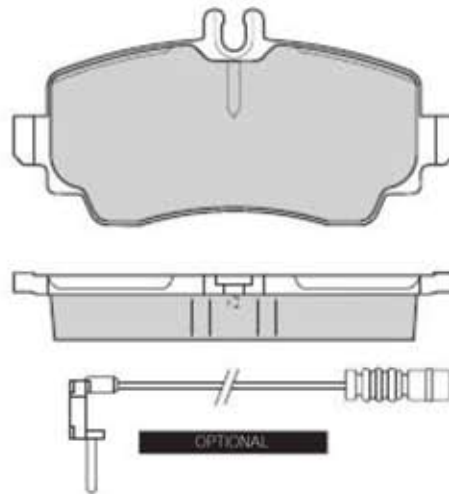



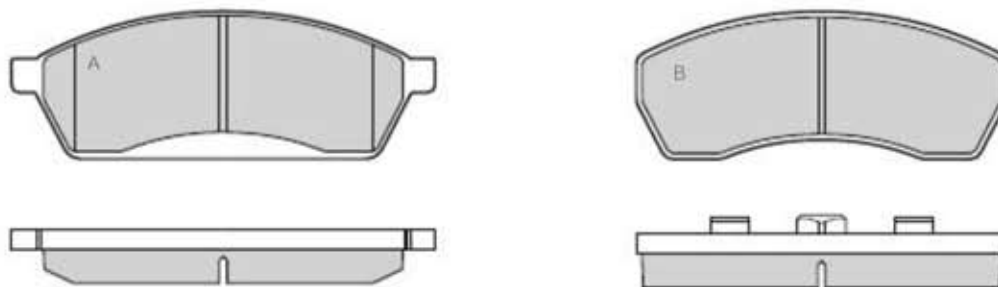

0763	MERCEDES	GIRLING	X	116,5	57,1	17	4	2	130
------	----------	---------	---	-------	------	----	---	---	-----



0764	SUBARU	SUMITOMO	X	A 112,1 B 98,1	39,1	14	2A-2B		
------	--------	----------	---	-------------------	------	----	-------	--	--

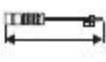

									
0765	CHRYSLER - DODGE PLYMOUTH	KELSEY-HAYES	X	A 164,1 B 164,7	A 54,8 B 51,6	16	2A-2B		

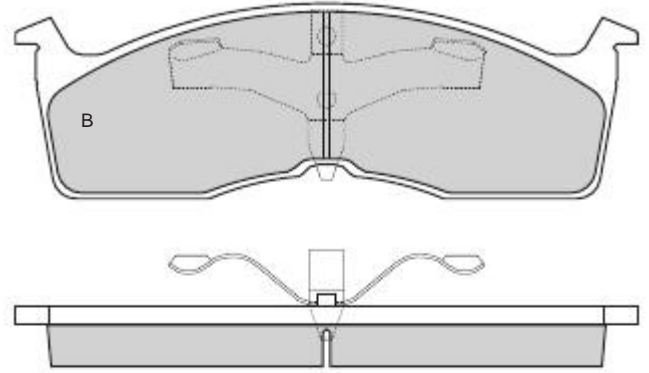
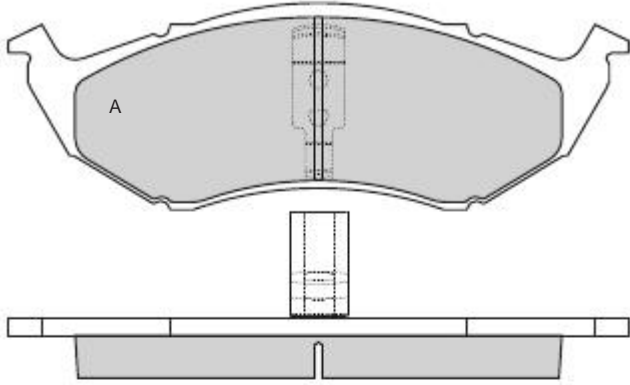



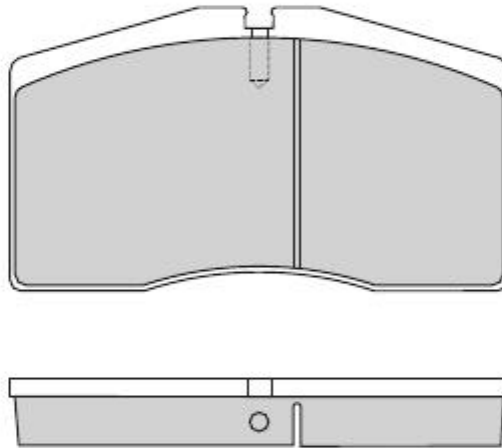



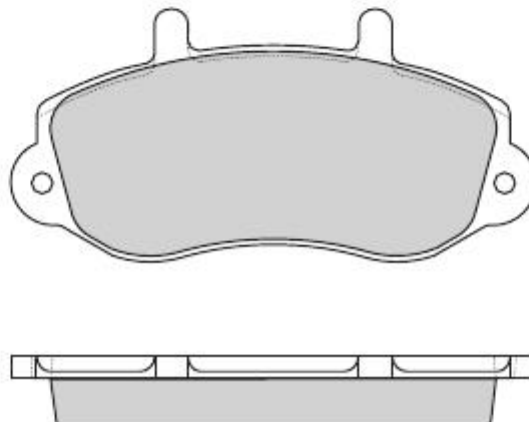

0766	PORSCHE	ATE	X	131,7	75	17,5	4		
-------------	---------	-----	---	-------	----	------	---	--	--



0767	OPEL - RENAULT	BENDIX	X	138,8	66,5	18	4		
-------------	----------------	--------	---	-------	------	----	---	--	--

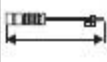

									
0768	IVECO FIAT	BREMBO	X	109,7	73,1	18	2A-2B	2	440

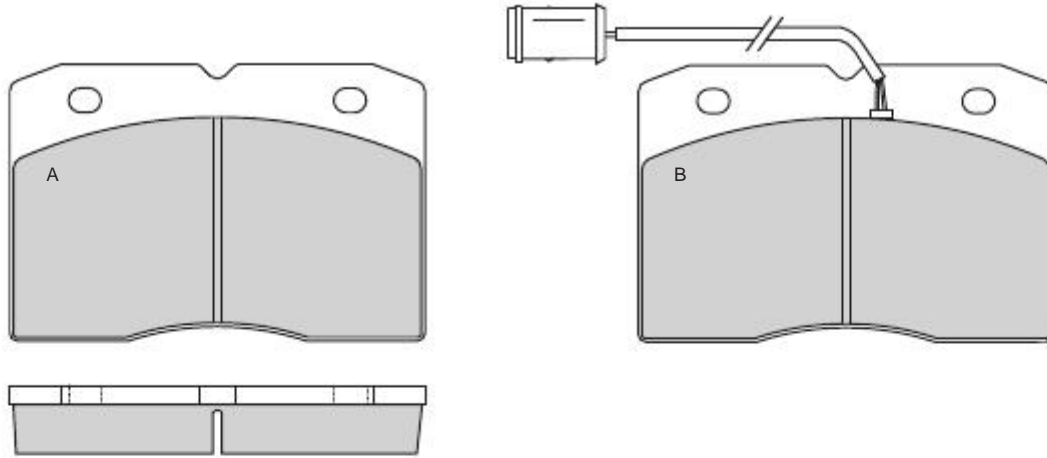



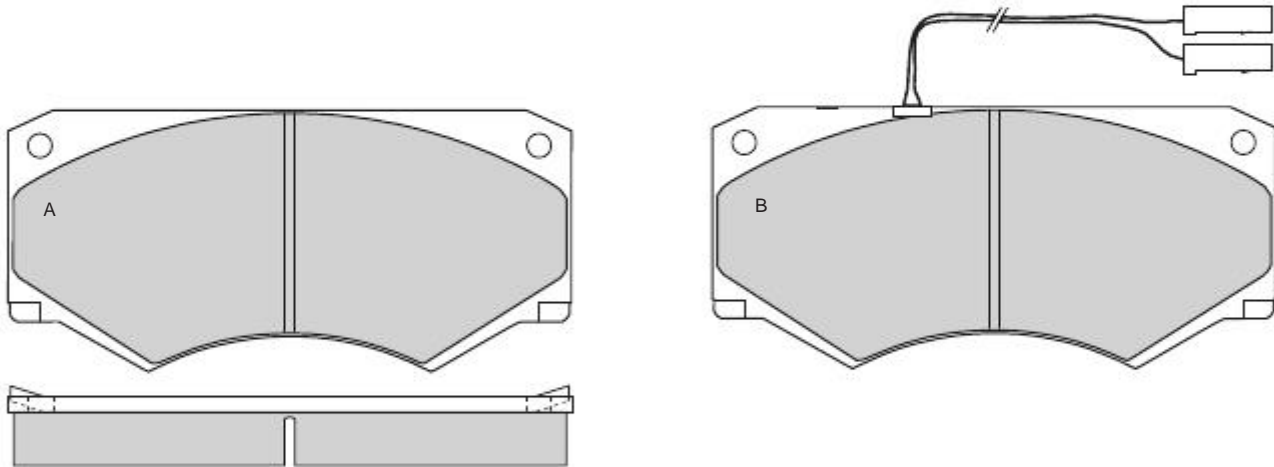



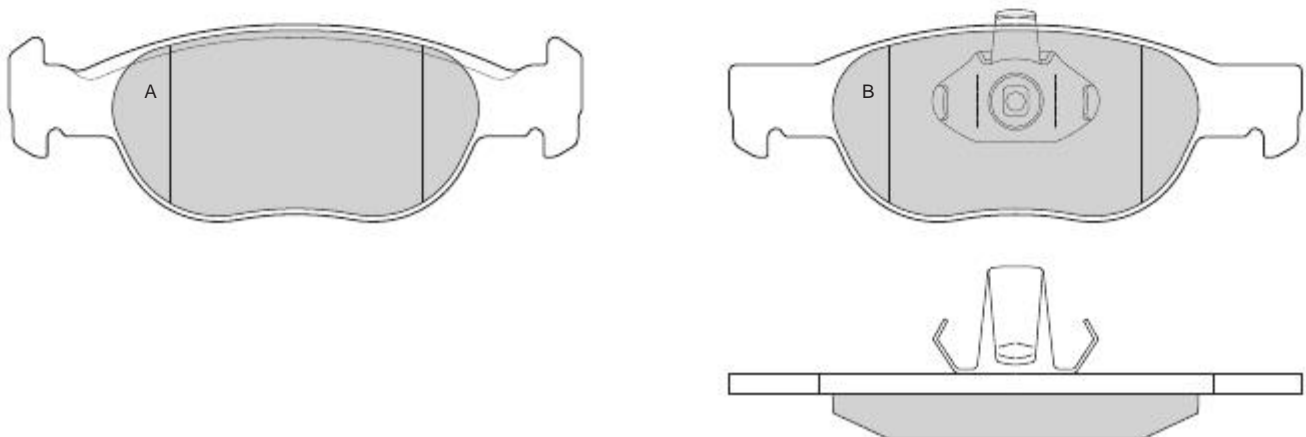



0769	IVECO FIAT	PERROT	X	149	69	18	2A-2B	2	750
-------------	------------	--------	---	-----	----	----	-------	---	-----



0770	FIAT - LANCIA	ATE	X	151,3	52	17,9	2A-2B		
-------------	---------------	-----	---	-------	----	------	-------	--	--



									
0771	MERCEDES	ATE	X	63,7	63,4	15,5	4		

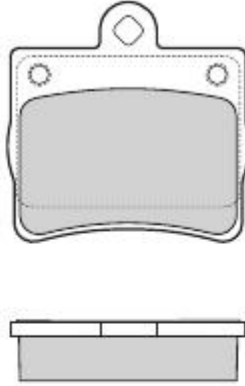



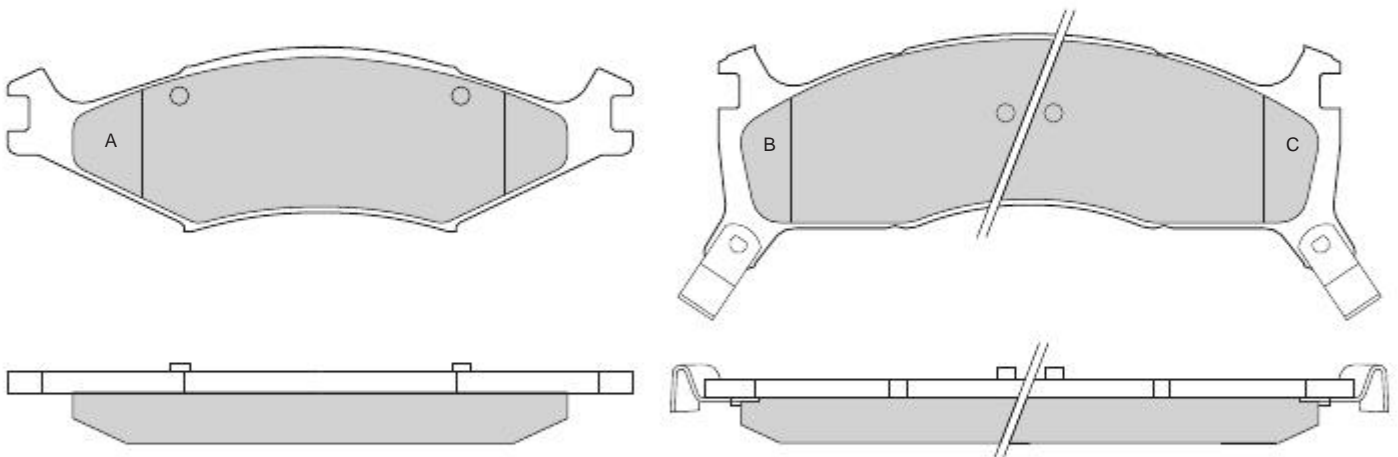



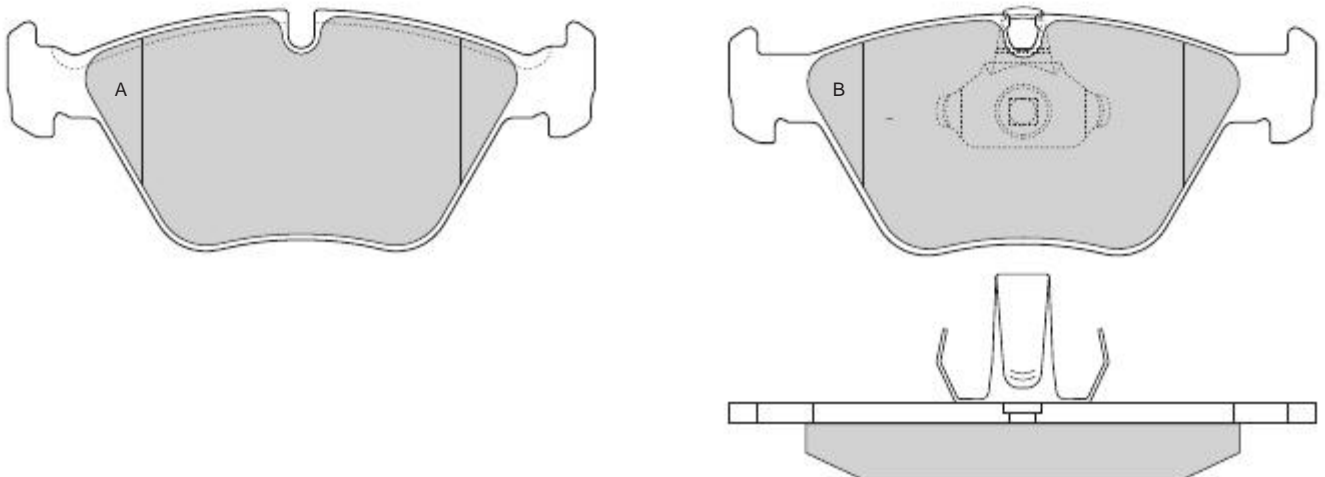

0772	KIA	KELSEY-HAYES	X	A 165,1 B 172,5	A 49,1 B 64,5	A 19 B 17	2A 1B-1C		
------	-----	--------------	---	--------------------	------------------	--------------	-------------	--	--



0773	BMW	ATE	X	A 154,6 B 155,2	64,2	20,3	2A-2B		
------	-----	-----	---	--------------------	------	------	-------	--	--

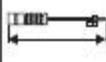

									
0774	BMW	ATE	X	156,3	73,6	19	2A-2B		

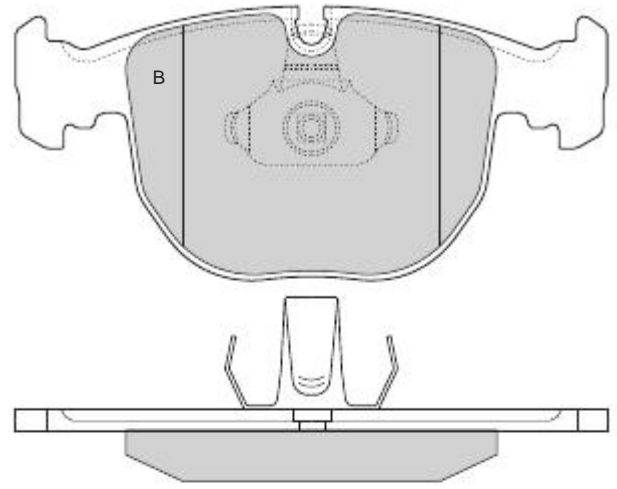
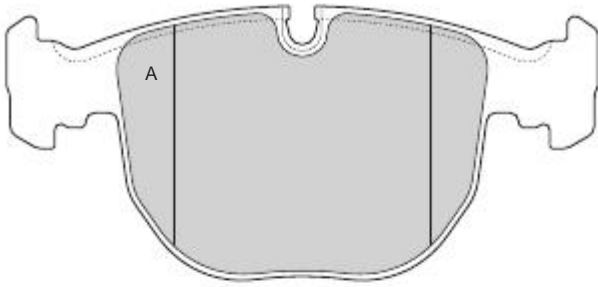



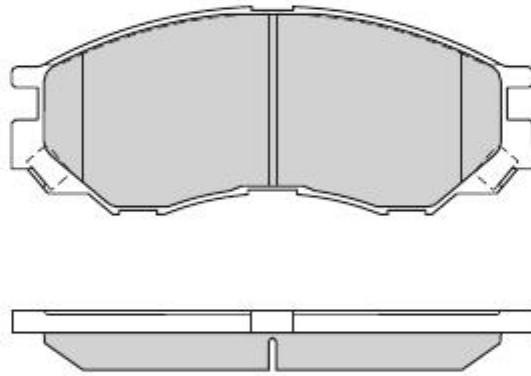



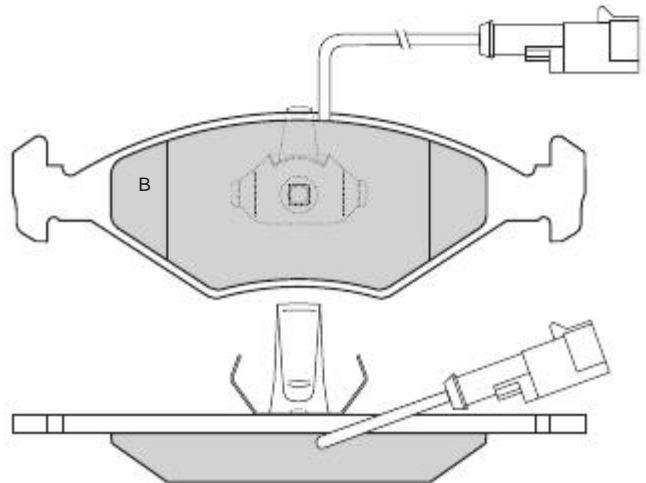



0775	MITSUBISHI	AKEBONO	X	137,8	55	15,7	4		
------	------------	---------	---	-------	----	------	---	--	--



0776	FIAT	ATE	X	151,3	50	18	2A-2B	2	200
------	------	-----	---	-------	----	----	-------	---	-----



									
0777	JEEP	KELSEY-HASEY	X	143	45,3	15	1A-1B 1C-1D		

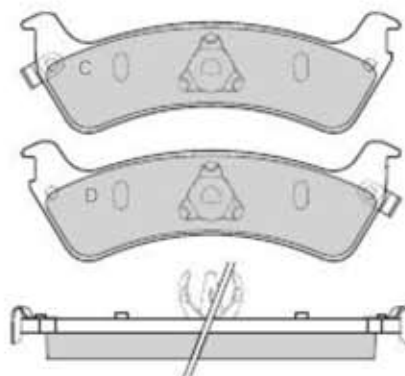
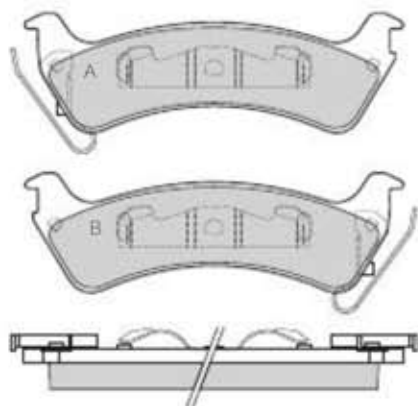



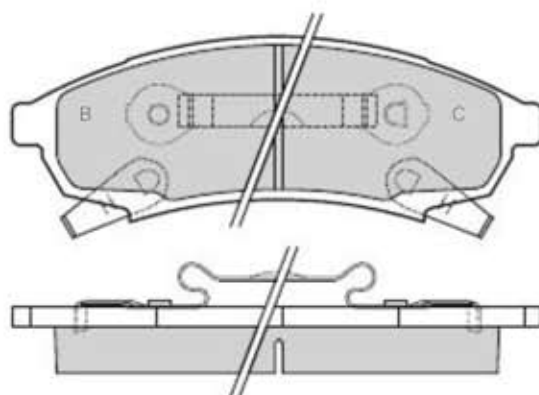
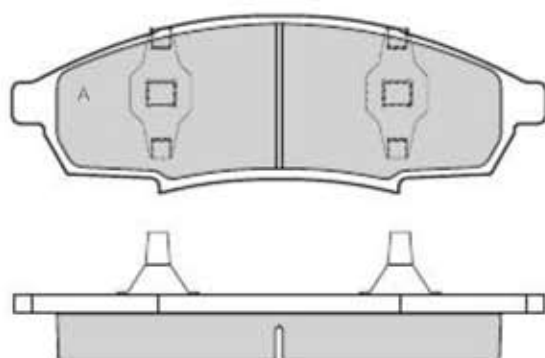



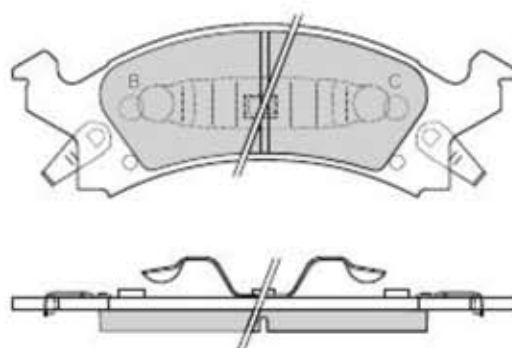
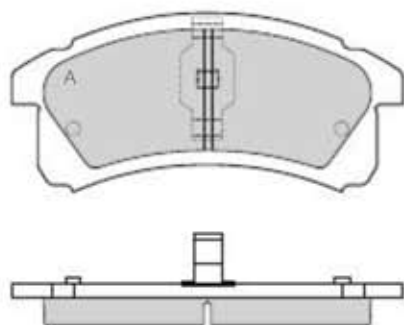



0778	BUICK - CHEVROLET OLDSMOBILE - PONTIAC	WAGNER	X	140,2	A 47,2 B 49,3	17,3	2A 1B-1C		
------	---	--------	---	-------	------------------	------	-------------	--	--



0779	BUICK - CHEVROLET OLDSMOBILE - PONTIAC	KELSEY-HAYES	X	A 147,5 B 189,8	A 67,4 B 65,3	A 15,4 B 12,8	2A 1B-1C		
------	---	--------------	---	--------------------	------------------	------------------	-------------	--	--



									
0780	FORD USA - LINCOLN MERCURY	KELSEY-HAYES	X	A 142,75 B-C 199	A 61 B-C 61,9	A 17 B-C 15	2A 1B-1C		

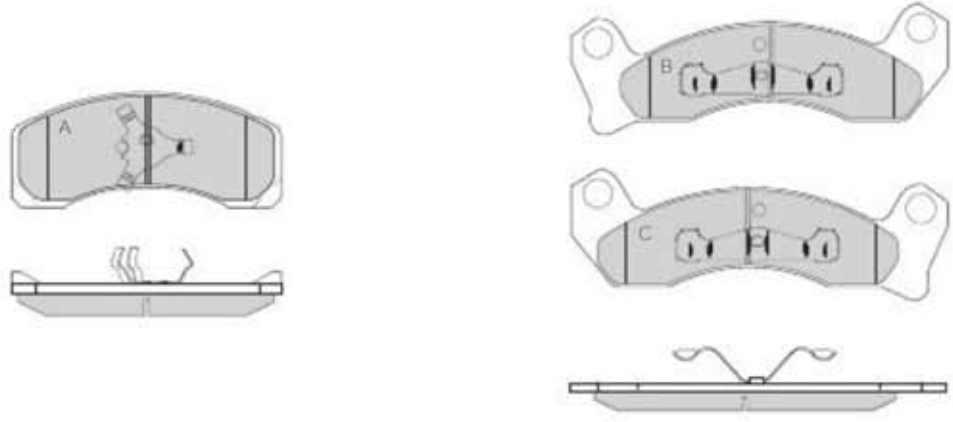



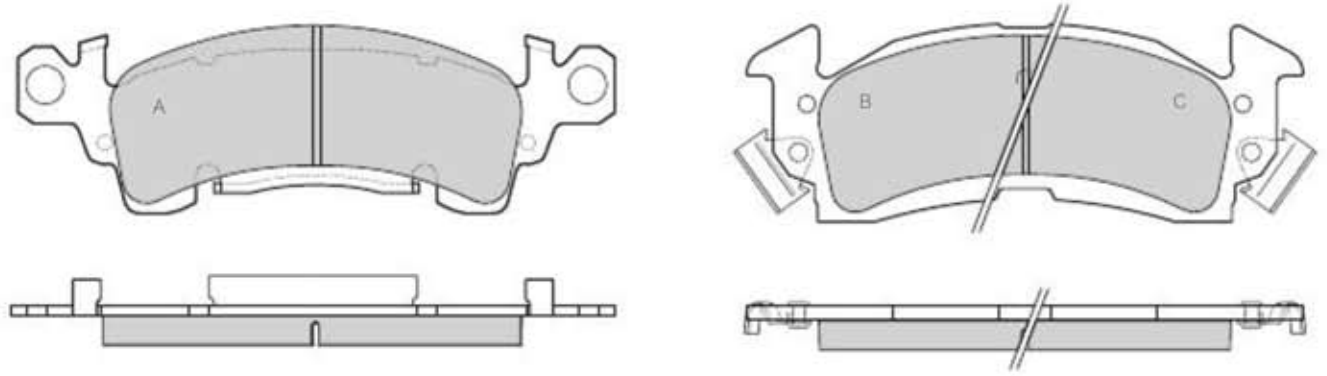



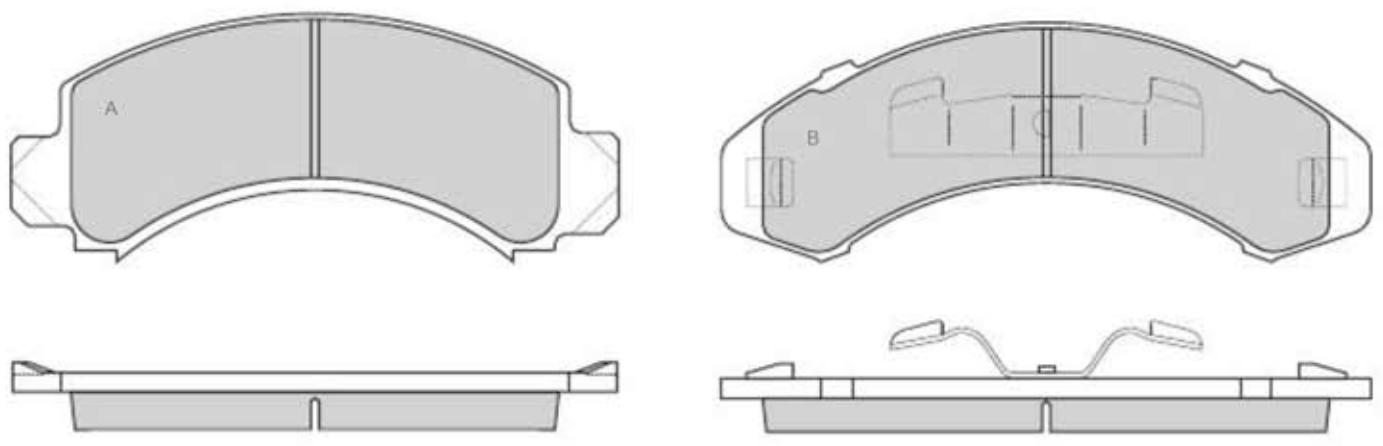

0781	BUICK - CADILLAC - CHEVROLET GMC - JEEP - PONTIAC	KELSEY-HAYES	X	X	A 197,4 B 183,9	A 64 B-C 65,5	A 13,2 B-C 14,8	2A 1B-1C	
------	--	--------------	---	---	--------------------	------------------	--------------------	-------------	--



0782	FORD USA	WAGNER	X	A 160,2 B 172	A 62,6 B 63,6	A 15 B 14	2A-2B		
------	----------	--------	---	------------------	------------------	--------------	-------	--	--

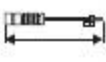

									
0783	FORD USA - FORD TRUCK LINCOLN - MERCURY	GIRLING	X	123,8	66,6	17,6	4		

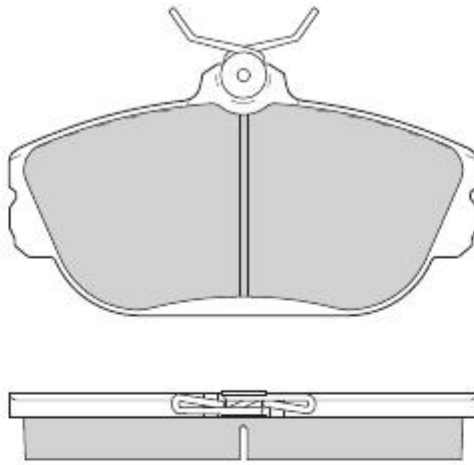



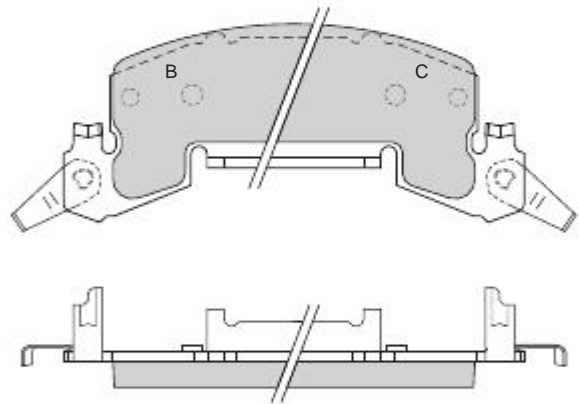
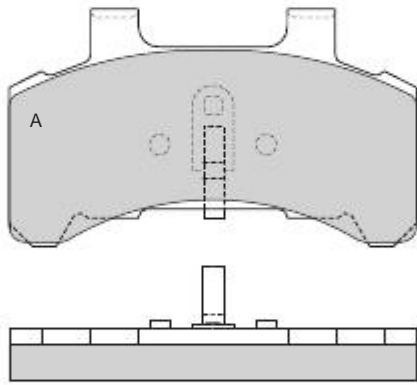



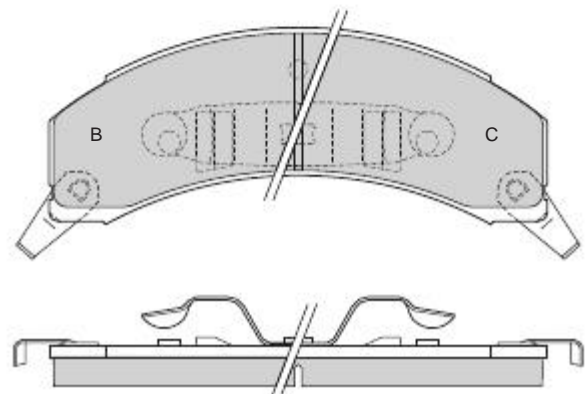
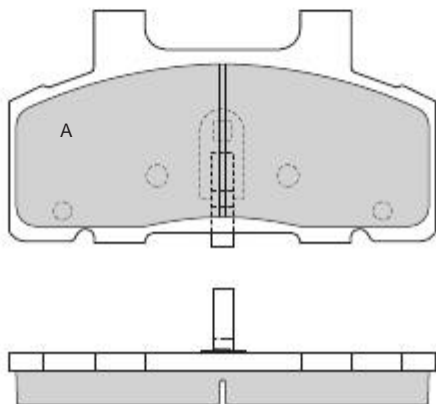

0784	BUICK - CHEVROLET OLDSMOBILE - PONTIAC	BENDIX	X	A 125,7 B-C 152,5	A 73,3 B-C 61,7	A 16 B-C 11,3	2A 1B-1C		
------	---	--------	---	----------------------	--------------------	------------------	-------------	--	--



0785	BUICK - CADILLAC - CHEVROLET OLDSMOBILE - PONTIAC	BENDIX	X	A 125,7 B 147,2	A 69,1 B 58,8	A 15 B 12	2A 1B-1C		
------	--	--------	---	--------------------	------------------	--------------	-------------	--	--

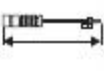

									
0786	BUICK - CADILLAC CHEVROLET - PONTIAC	BENDIX	X	A 125,7 B-C 142,6	A 72,8 B-C 61,45	A 16 B-C 11	2A 1B-1C		

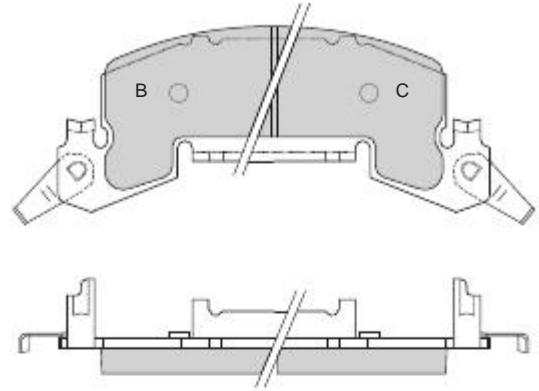
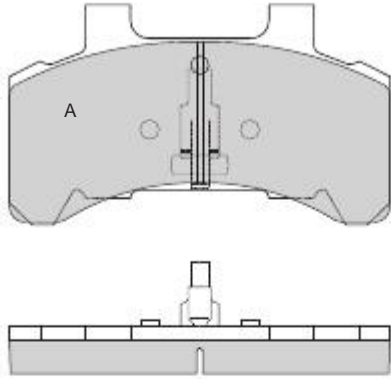



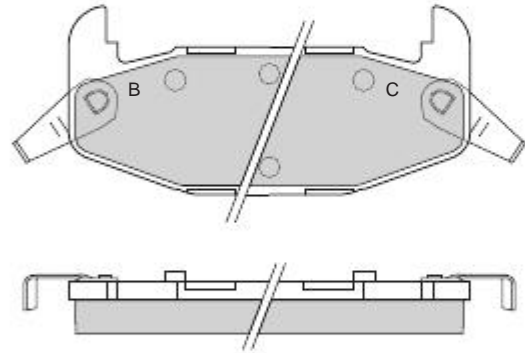
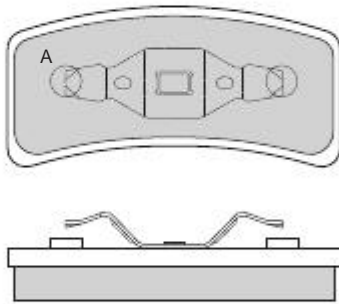



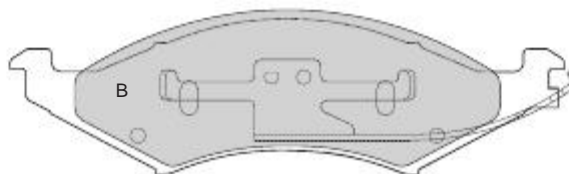
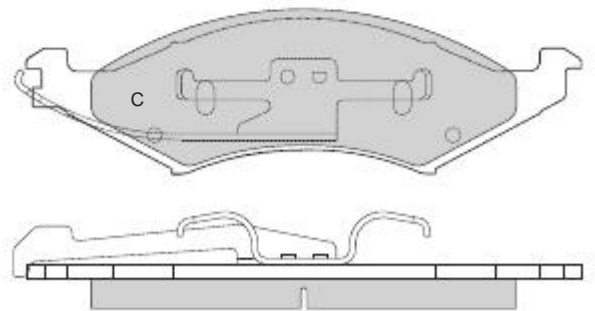
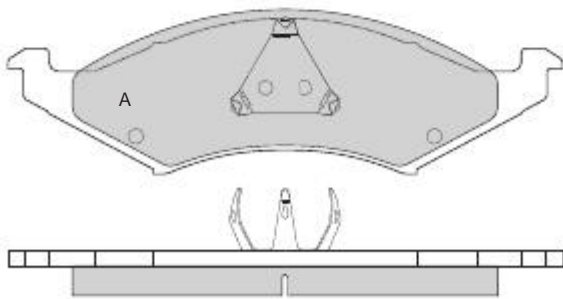

0787	BUICK - CHEVROLET			B-C 106,1	A 42,4 B-C 49,75	13,8	2A 1B-1C		
-------------	-------------------	--	--	-----------	---------------------	------	-------------	--	--



0788	FORD USA - LINCOLN MERCURY	KELSEY-HAYES	X	188	54,5	15	2A 1B-1C		
-------------	-------------------------------	--------------	---	-----	------	----	-------------	--	--

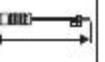

									
0789	BUICK - CADILLAC CHEVROLET - PONTIAC	KELSEY-HAYES	X	A 147,6 B-C 212,65	A 67,3 B-C 66,4	A 17 B-C 16	2A 1B-1C		

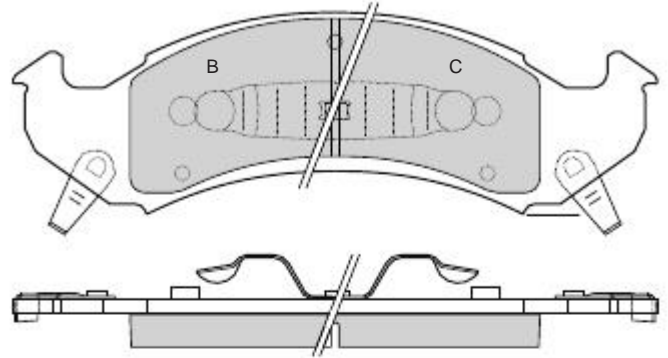
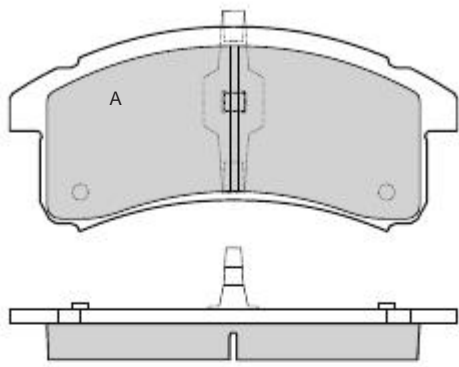



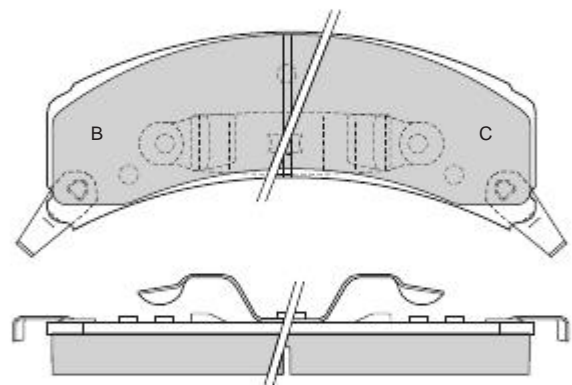
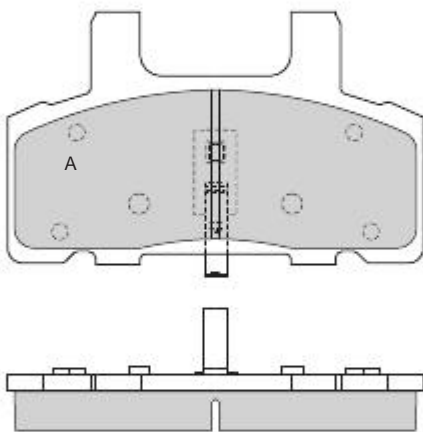



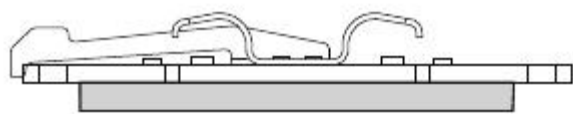
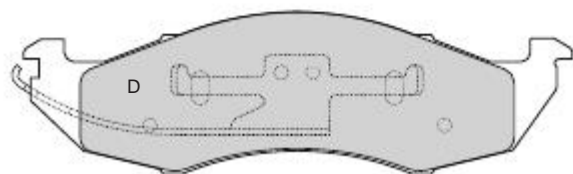
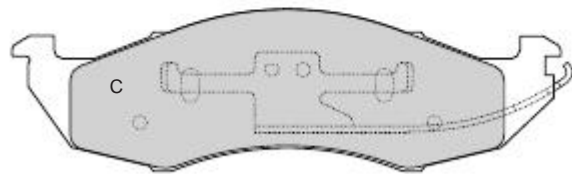
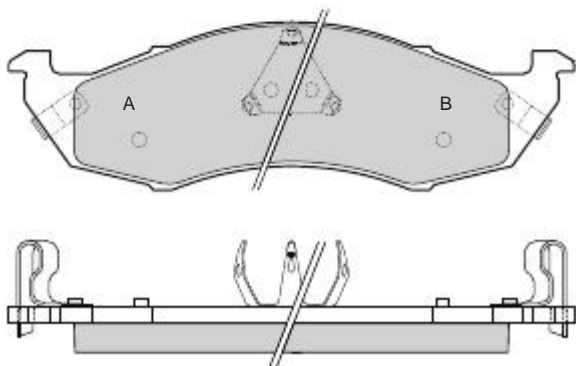



0790	CHEVROLET - GMC	BENDIX	X	A 126 B-C 147,3	A 76,4 B-C 59,4	A 16,8 B-C 15,8	2A 1B-1C		
------	-----------------	--------	---	--------------------	--------------------	--------------------	-------------	--	--



0791	MERCURY - NISSAN	KELSEY-HAYES	X	188	A-B 56,2 C-D 55,7	15,8	1A-1B 1C-1D		
------	------------------	--------------	---	-----	----------------------	------	----------------	--	--



									
0792	FORD USA	WAGNER	X	192	70	17	2A-2B		

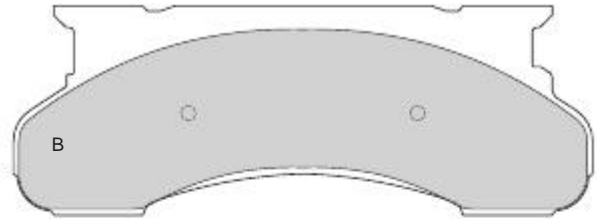
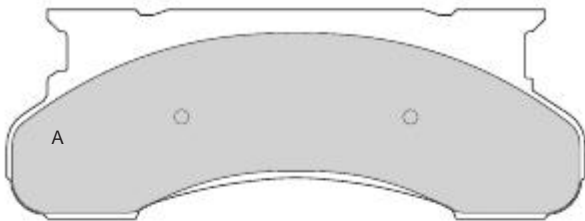



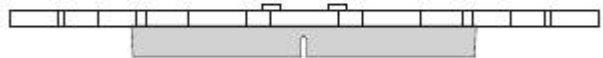
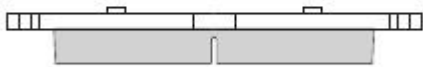
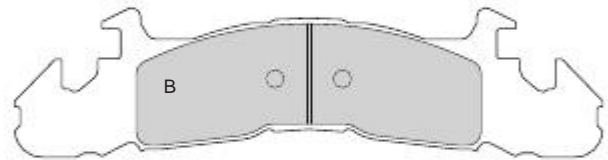
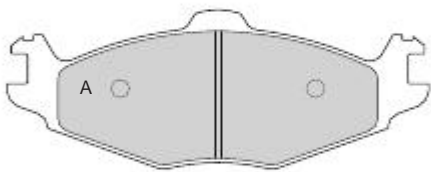



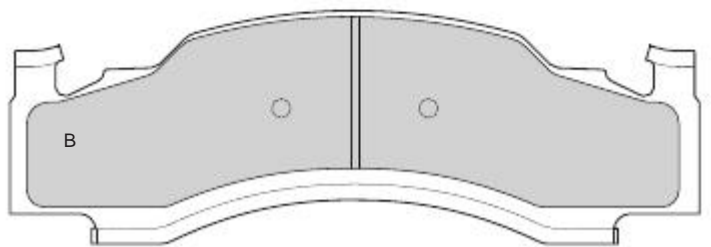
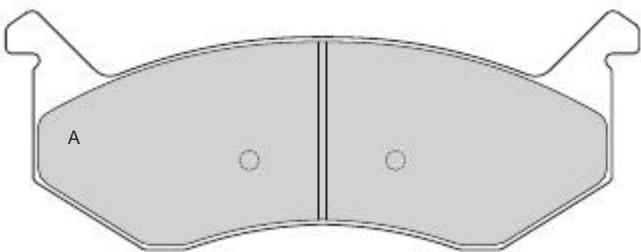

0793	CHRYSLER - DODGE PLYMOUTH	KELSEY-HAYES	X	A 156 B 221,7	A 60 B 56,2	A 19 B 17,9	2A-2B		
------	------------------------------	--------------	---	------------------	----------------	----------------	-------	--	--



0794	DODGE - CHRYSLER	WAGNER	X	A 165,1 B 179,5	A 62,6 B 60,9	A 17,3 B 12,2	2A-2B		
------	------------------	--------	---	--------------------	------------------	------------------	-------	--	--

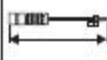

									
0795	FORD TRUCK	KELSEY-HAYES	X		193,7	54,2	16,4	2A-2B	

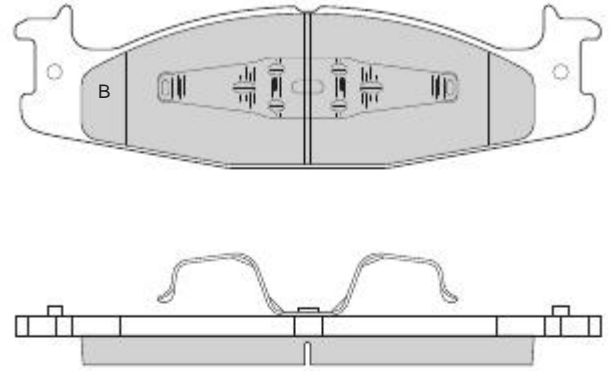
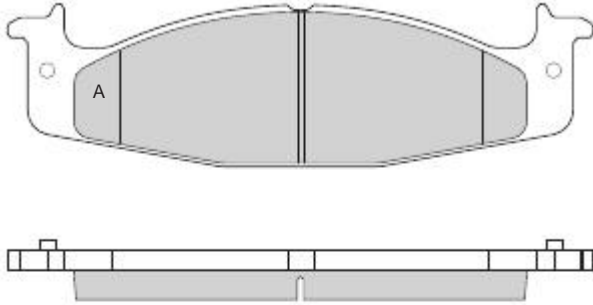



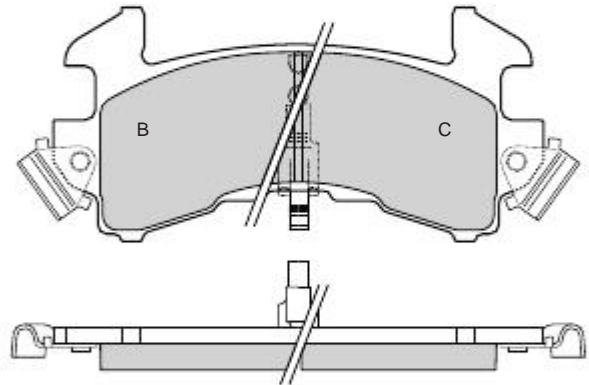
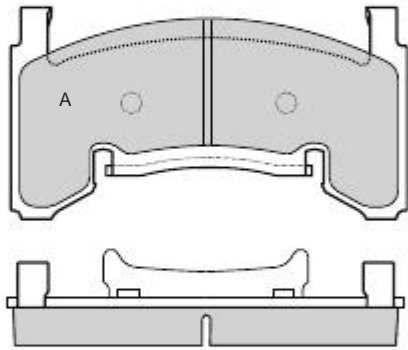



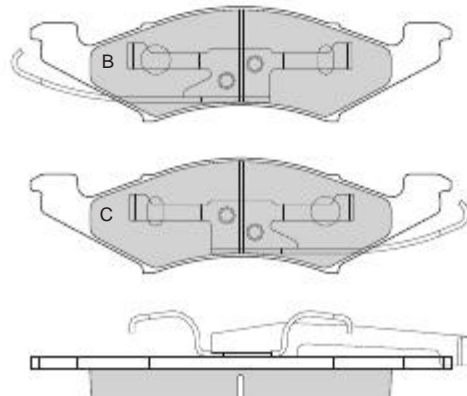
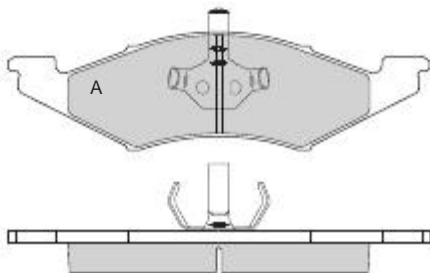



0796	BUICK - CHEVROLET CADILLAC - GMC -PONTIAC	BENDIX	X	X	A 123,2 B 152,4	A 56,4 B 72,9	A 15 B 13,2	2A 1B-1C	
-------------	--	---------------	----------	----------	----------------------------	--------------------------	------------------------	---------------------	--



0797	FORD - MERCURY	KELSEY-HAYES	X		164,7	A 45 B - C 46	16,9	2A 1B-1C	
-------------	-----------------------	---------------------	----------	--	--------------	--------------------------	-------------	---------------------	--



									
0798	FORD TRUCK	WAGNER	X	A 157,3 B 182,9	A 59 B 59,7	A 16 B 12,1	2A-2B		

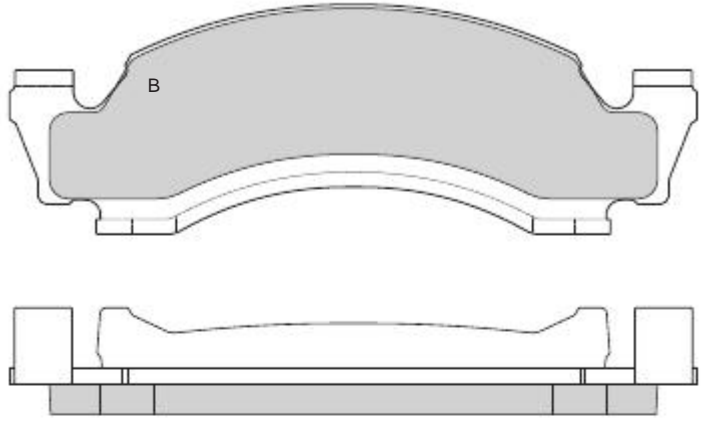
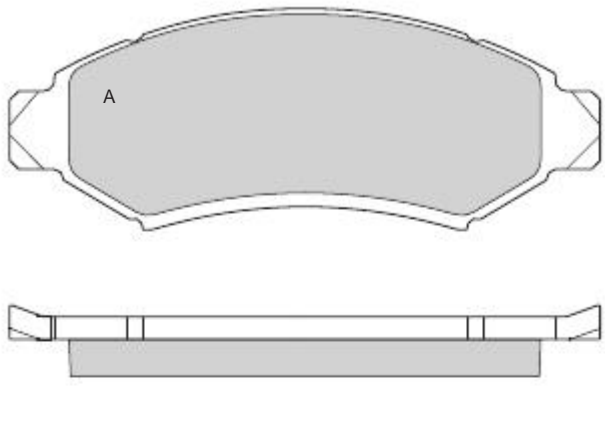

0799	BUICK - CADILLAC - CHEVROLET OLDSMOBILE - PONTIAC	DELCO	X	A 147,5 B 212,65	A 67,5 B 66,4	A 17 B 16	2A 1B-1C		
-------------	--	--------------	----------	---------------------	------------------	--------------	---------------------	--	--

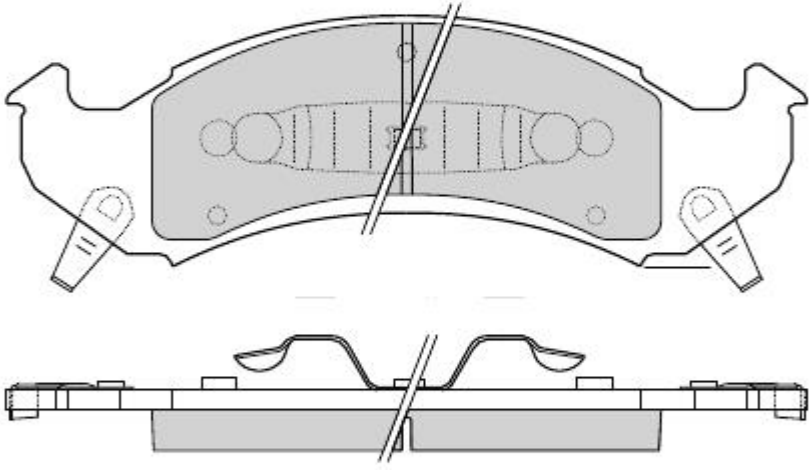
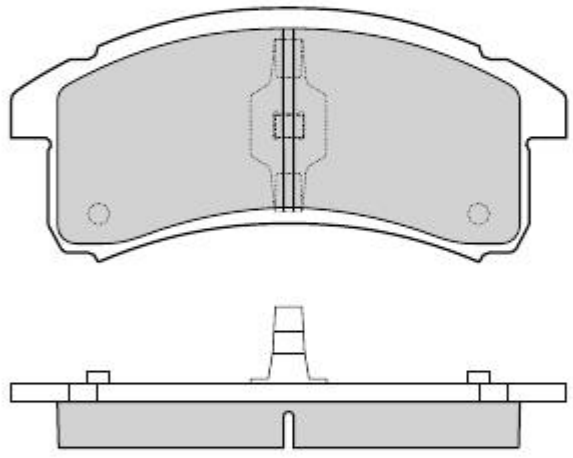

0800	MITSUBISHI	AKEBONO	X	98,9	37,7	14,2	2A-2B		
-------------	-------------------	----------------	----------	------	------	------	--------------	--	--

