

0801	RENAULT	GIRLING	X	129,9	63	18	2A-2B	2	305

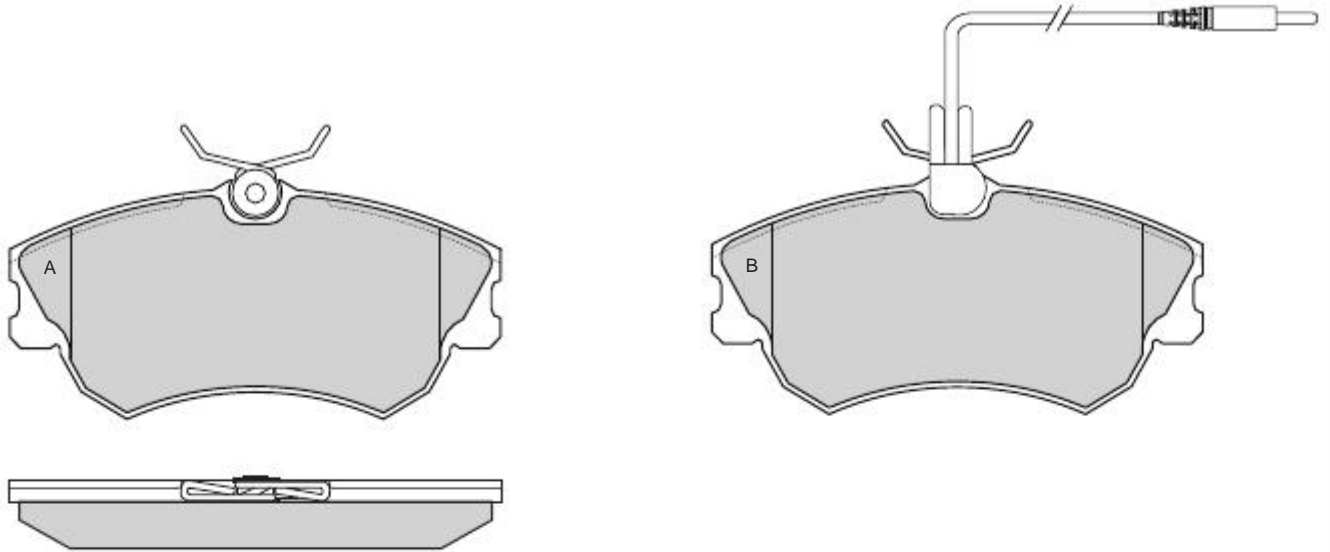

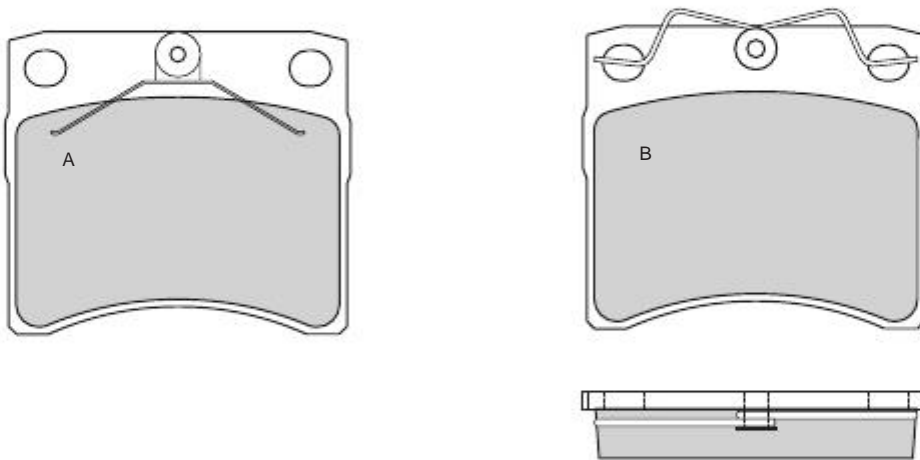

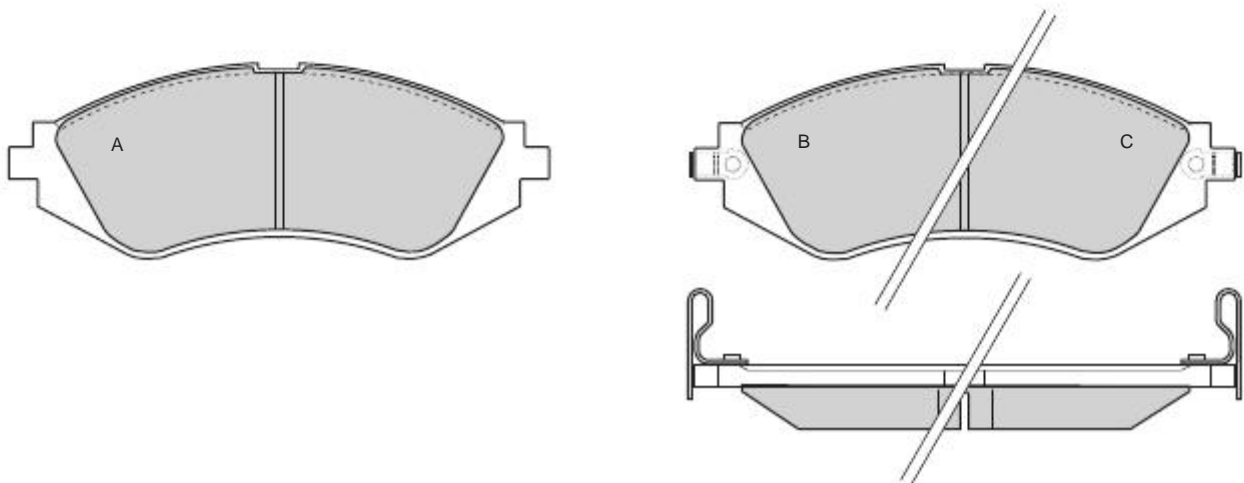





0802	VOLKSWAGEN	GIRLING	X	91,4	80	18	2A-2B		
-------------	-------------------	----------------	----------	-------------	-----------	-----------	--------------	--	--



0803	DAEWOO	AKEBONO	X	143	52	17	2A 1 B - 1C		
-------------	---------------	----------------	----------	------------	-----------	-----------	------------------------	--	--

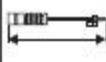

									
0804	DAEWOO	AKEBONO	X	126,7	48,4	16	4		

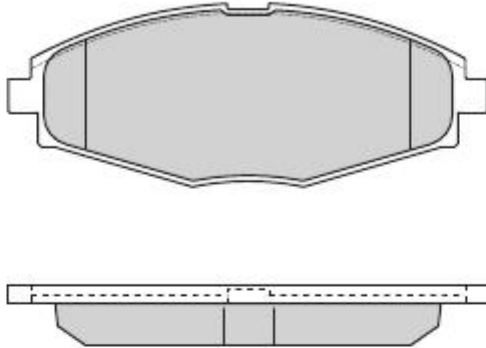



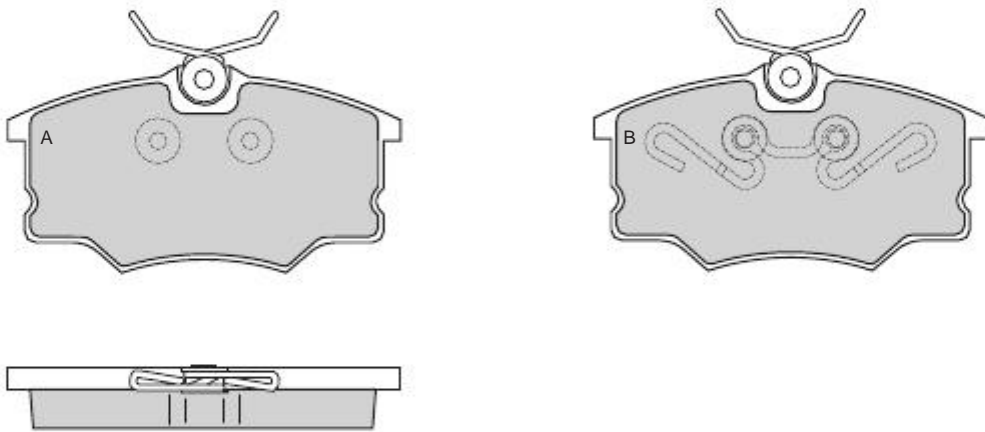



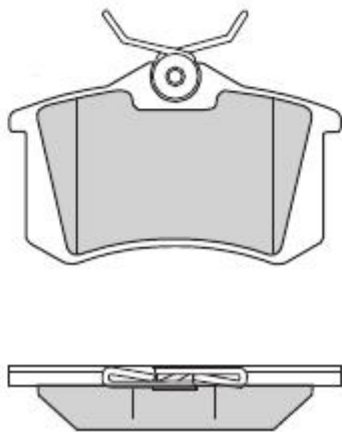



0805	OPEL	GIRLING	X	103,9	53,7	16,2	2A-2B		
------	------	---------	---	-------	------	------	-------	--	--



0806	AUDI - CITROEN - FIAT - FORD LANCIA - PEUGEOT - SEAT - SKODA		X	87	52,9	17	4		
------	---	--	---	----	------	----	---	--	--



									
0807	PEUGEOT - SEAT VOLKSWAGEN	GIRLING	X	87	52,9	15	4		

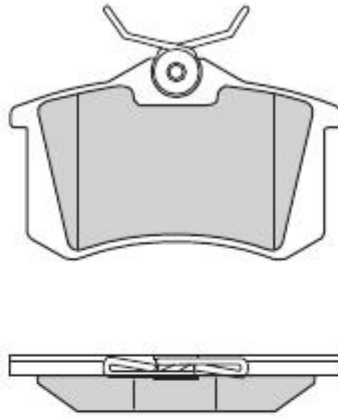



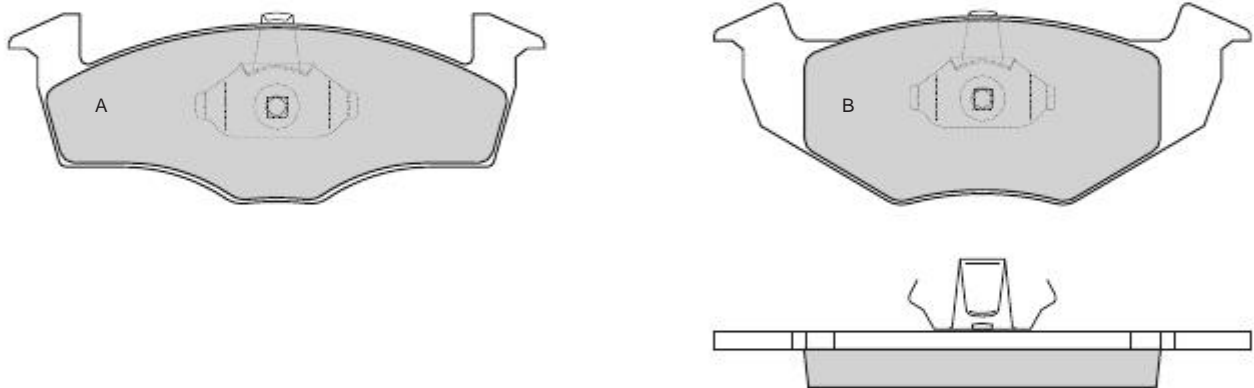



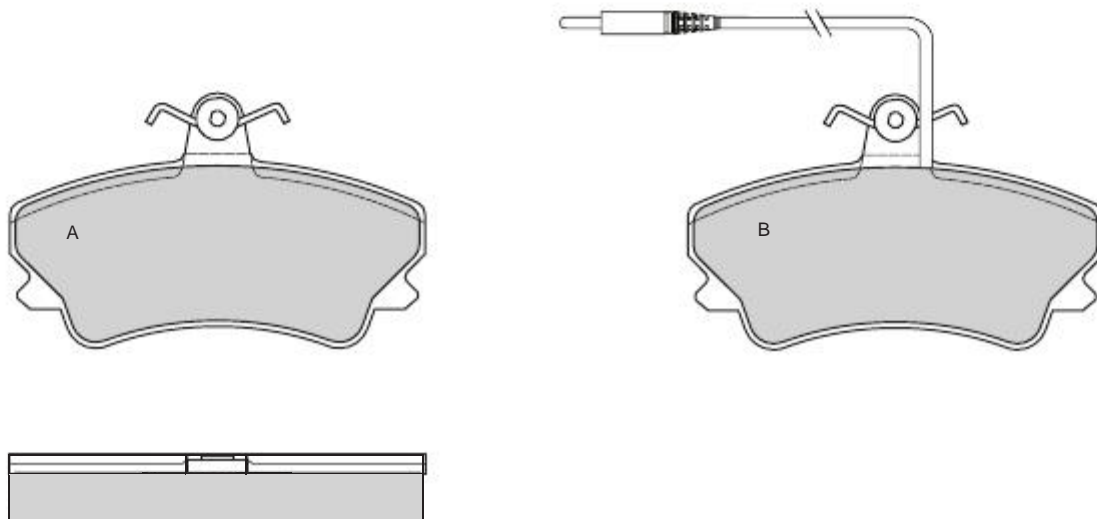



0808	SEAT - VOLKSWAGEN	KELSEY-HAYES	X	141,8	A 50,6 B 51,2	15	2A-2B		
-------------	-------------------	--------------	---	-------	------------------	----	-------	--	--



0809	RENAULT	GIRLING	X	109,9	67,6	18	2A-2B	2	285
-------------	---------	---------	---	-------	------	----	-------	---	-----



									
0810	OPEL - VAUXHALL	ATE	X	A-B 160 C-D 177,6	A-B 62,5 C-D 62,1	A-B 17 C-D 18,4	1A-1B 1C-1D		

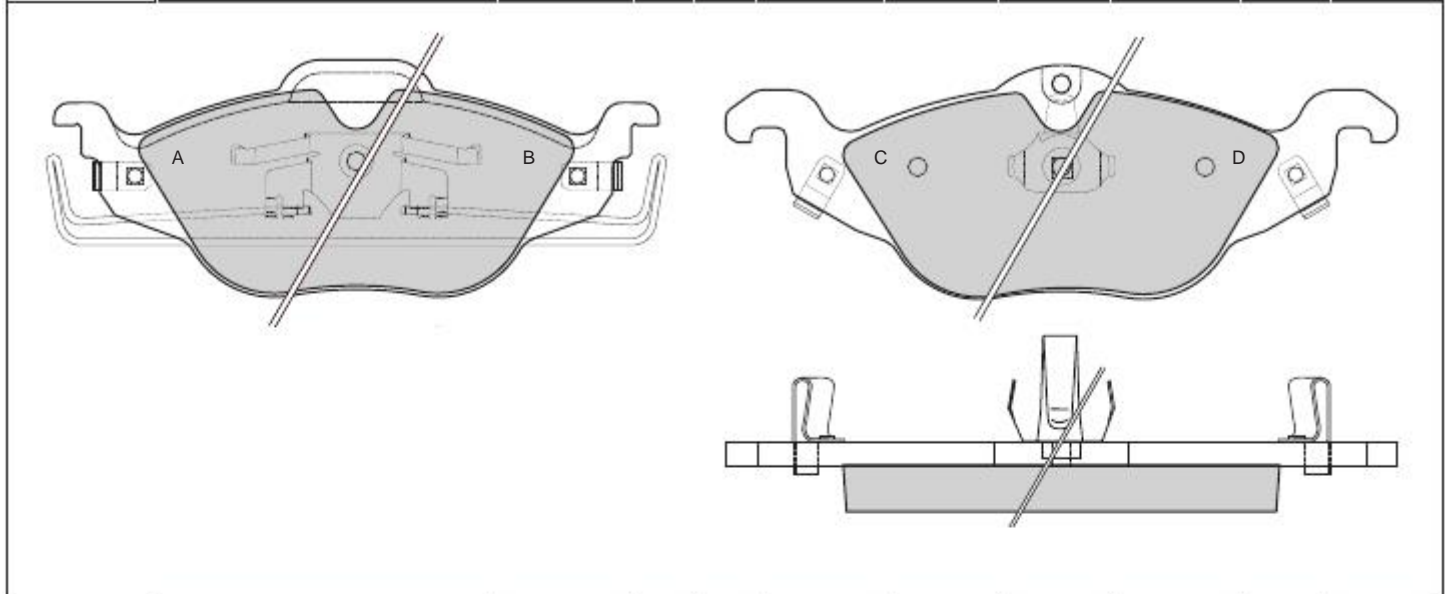



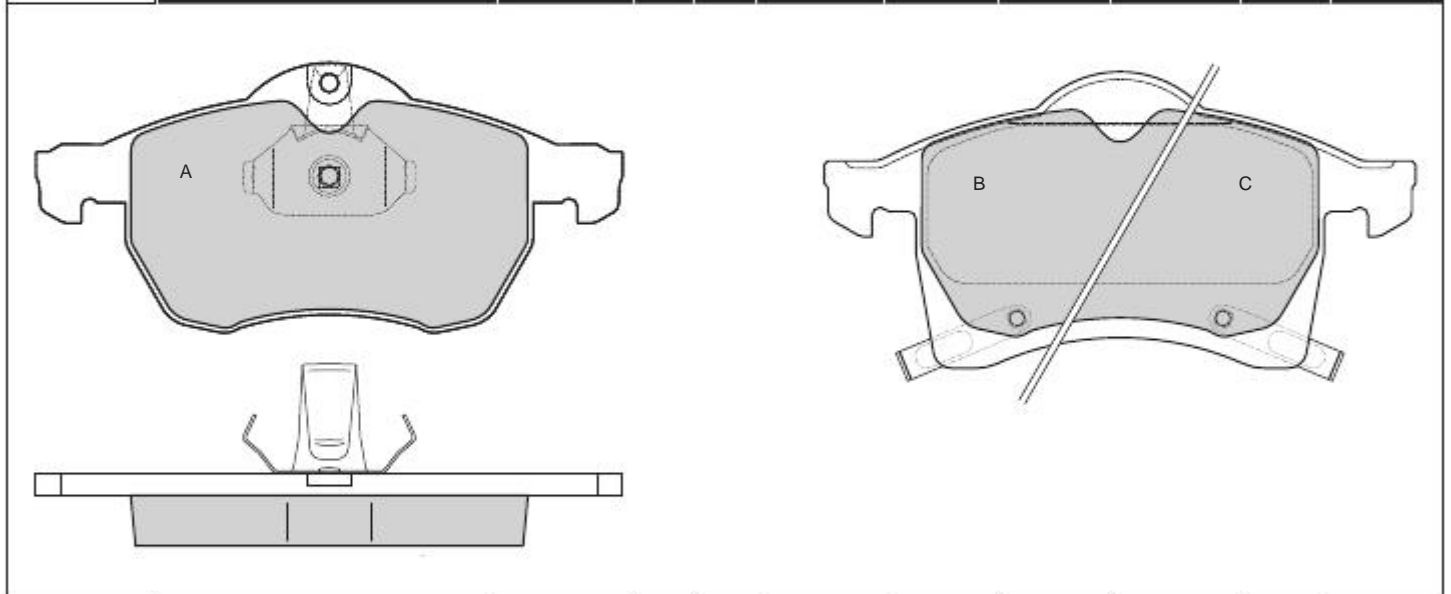



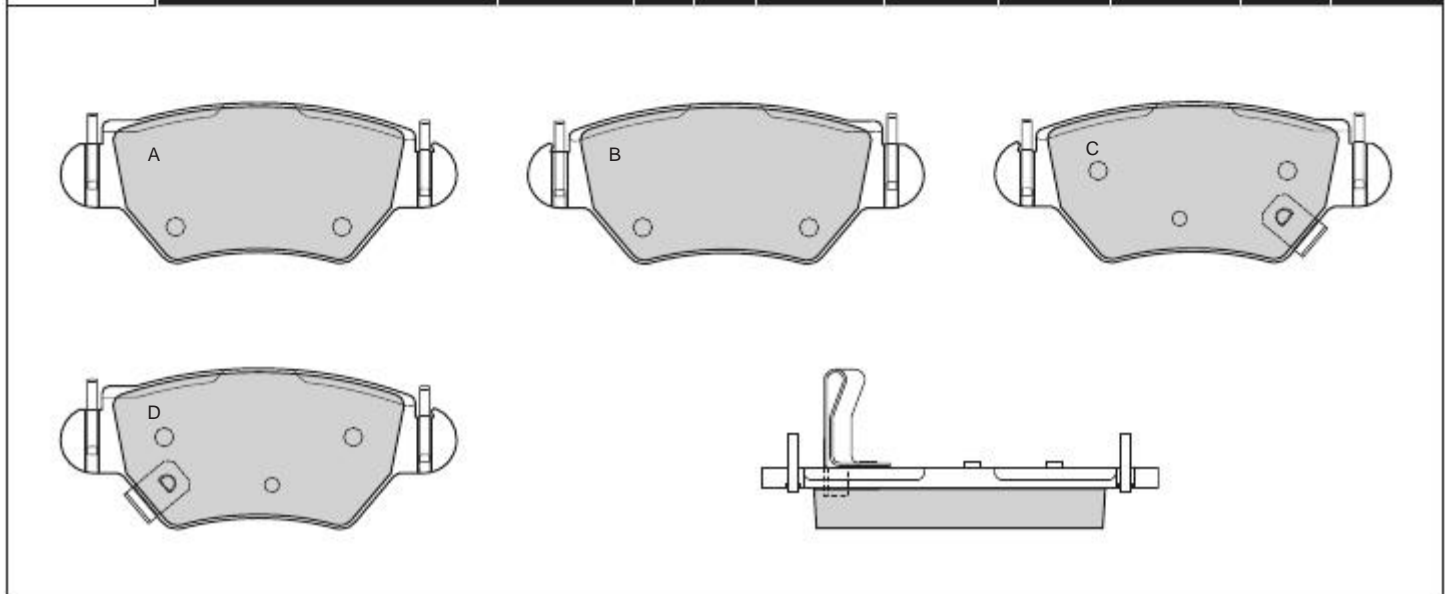



0811	OPEL - VAUXHALL	ATE	X	A 155,2 B-C 156,4	A 71,6 B-C 78,6	19	2A 1B-1C		
------	-----------------	-----	---	----------------------	--------------------	----	-------------	--	--



0812	OPEL - VAUXHALL	BOSCH	X	104,8	42,5	16,2	1A-1B 1C-1D		
------	-----------------	-------	---	-------	------	------	----------------	--	--



									
0813	SAAB	ATE	X	A 155,3 B 156,3	74	19,5	2A 1B-1C		

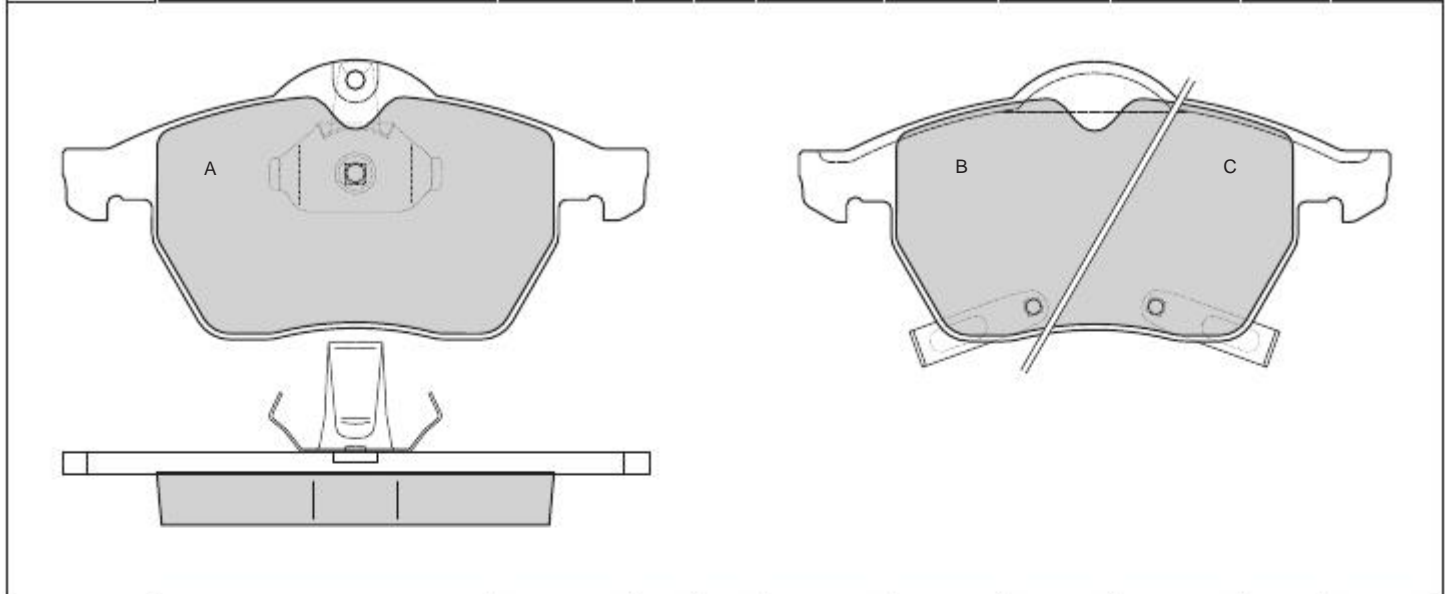



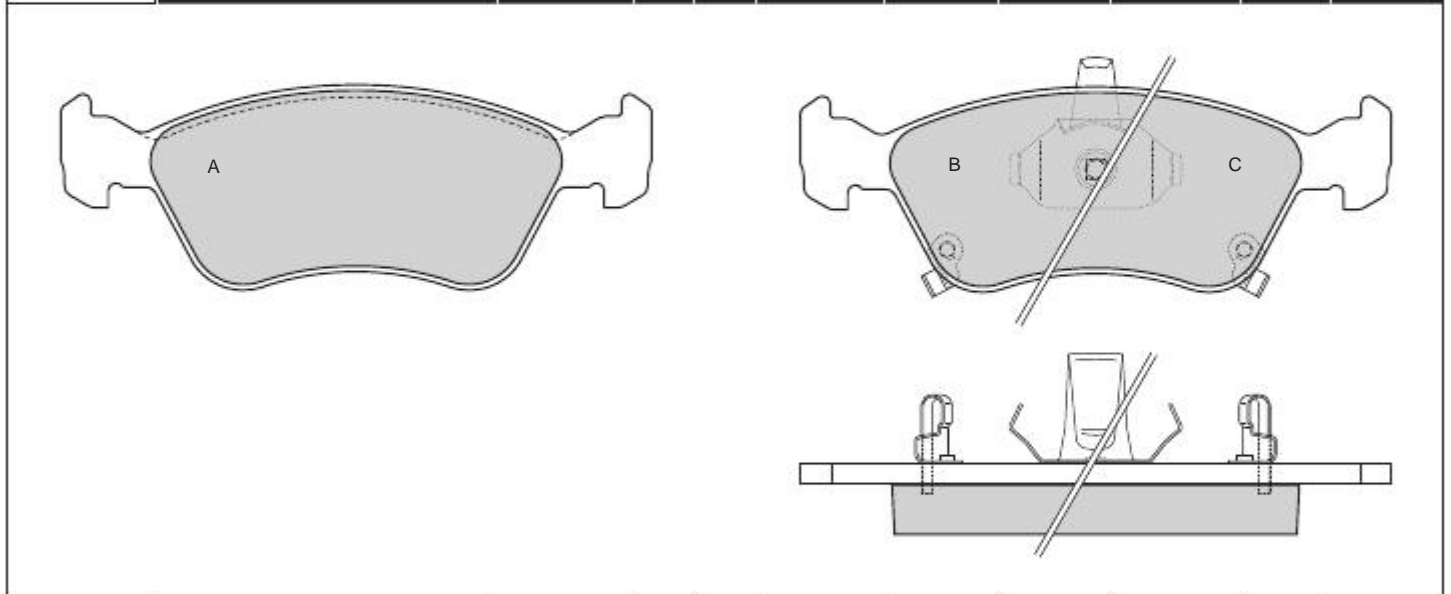



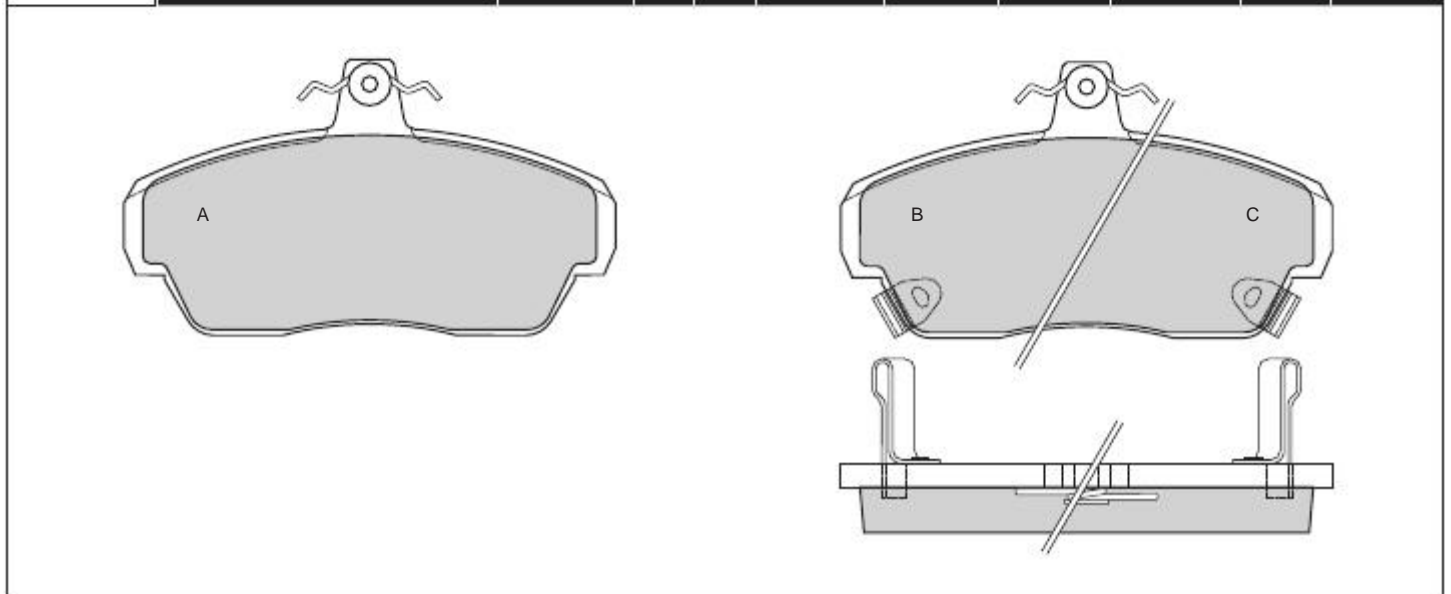

0814	TOYOTA	ATE	X	156,3	54,6	18,2	2A 1B-1C		
------	--------	-----	---	-------	------	------	-------------	--	--



0815	ROVER	GIRLING	X	130	73	18	2A 1B-1C		
------	-------	---------	---	-----	----	----	-------------	--	--

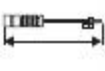

									
0816	AUDI	ATE	X	156,4	74,2	20,3	2A 1B-1C	1+1	215

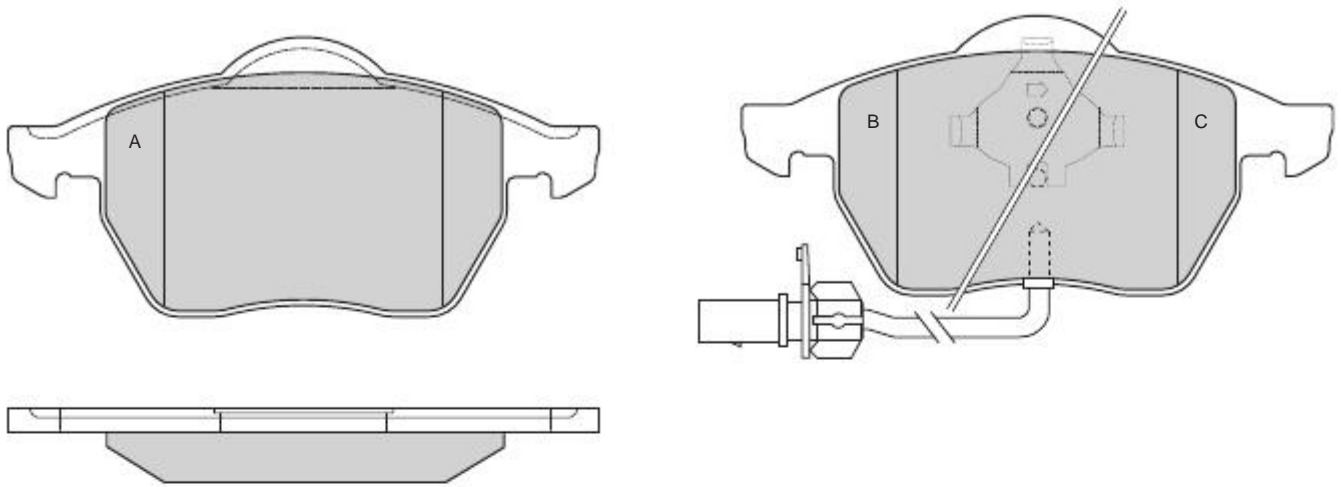



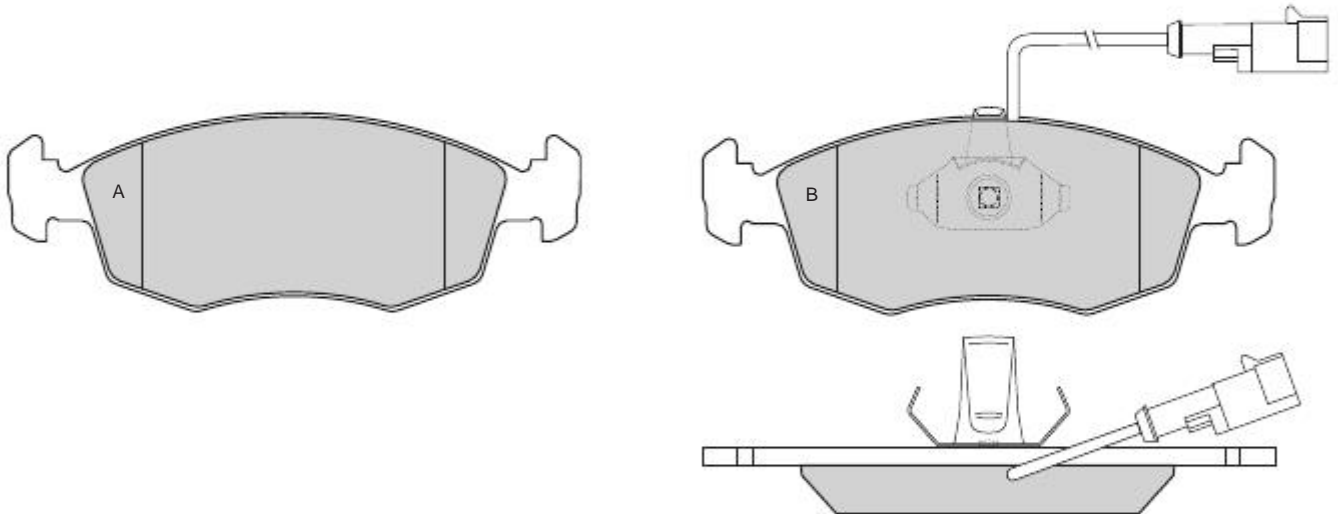



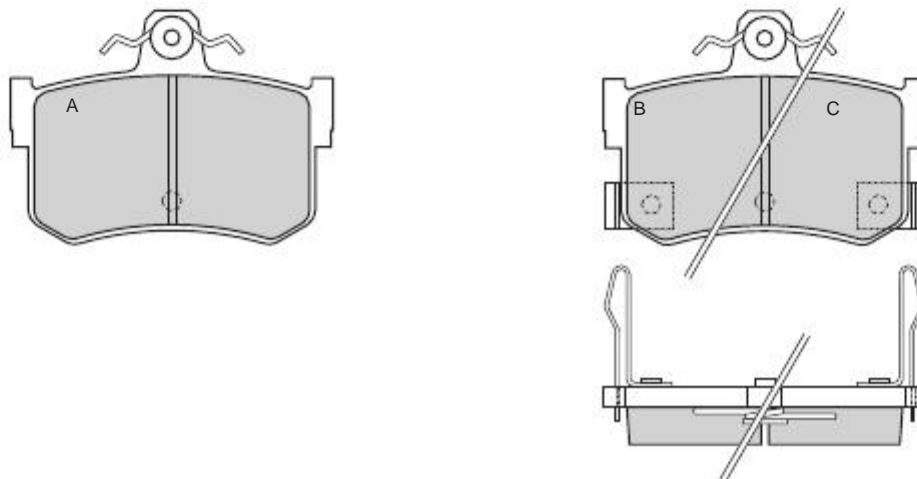



0817	FIAT	ATE	X	151,3	52,5	18,1	2A-2B	2	250
-------------	------	-----	---	-------	------	------	-------	---	-----



0818	ROVER	GIRLING	X	85,2	62,2	15	2A 1 B - 1C		
-------------	-------	---------	---	------	------	----	----------------	--	--



									
0819	SUBARU	AKEBONO	X	137,8	59,7	17	4		

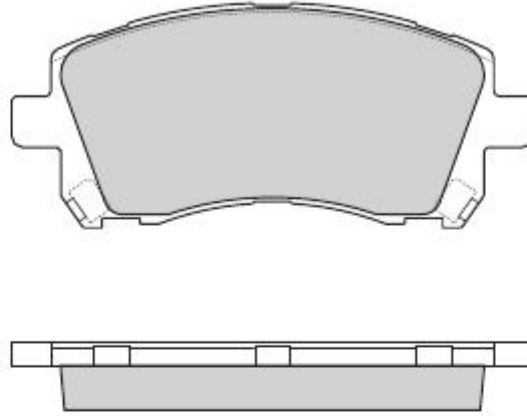



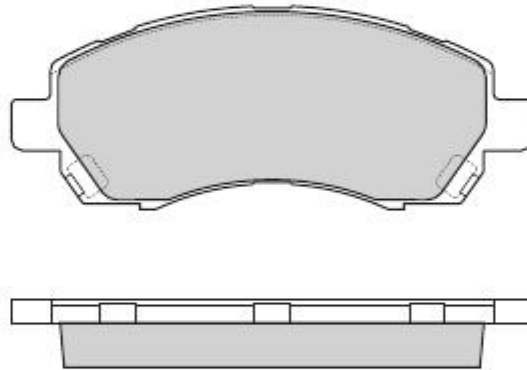



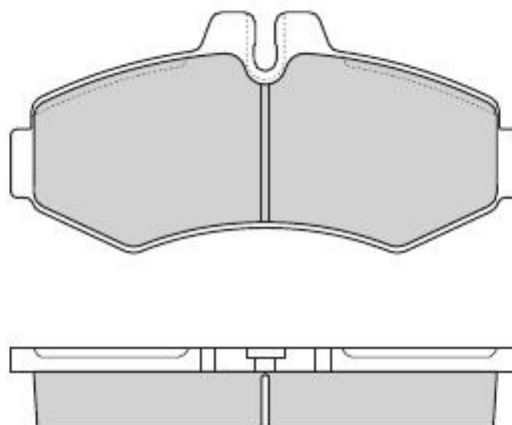



0820	SUBARU	AKEBONO	X	137,8	53,8	17	4		
-------------	--------	---------	---	-------	------	----	---	--	--



0821	MERCEDES	PERROT	X	134,5	64,3	21	4		
-------------	----------	--------	---	-------	------	----	---	--	--



									
0822	FIAT	ATE	X	151,3	50	18	2A-2B		

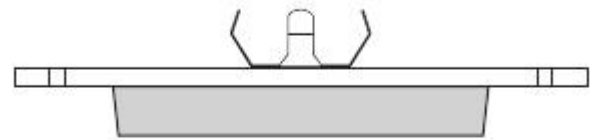
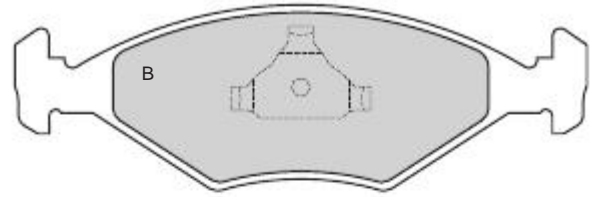



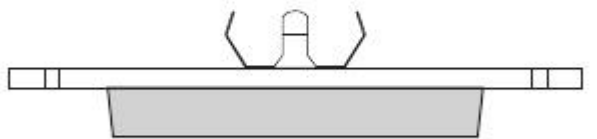
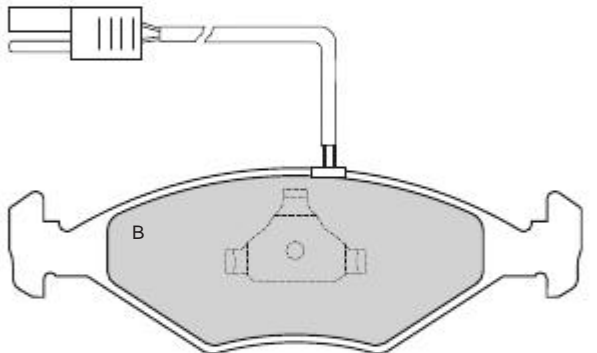
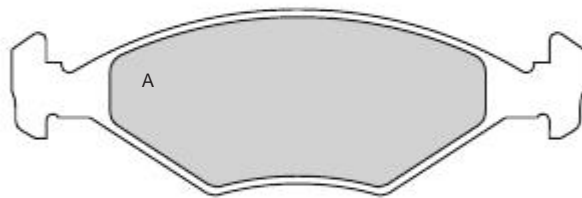



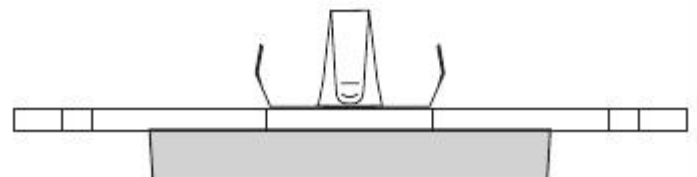
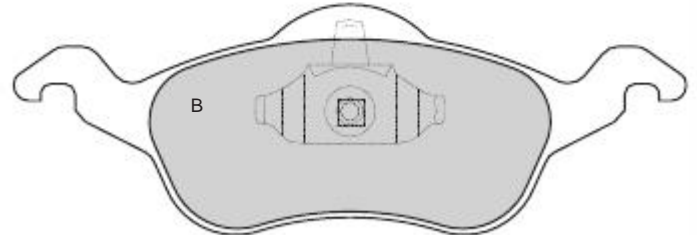
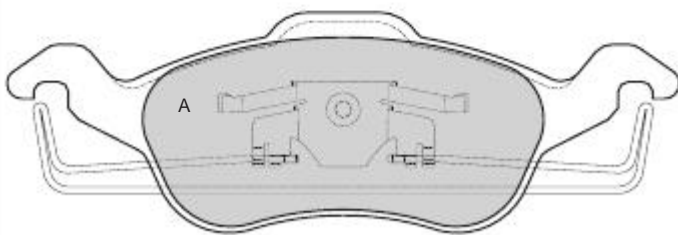

0823	FIAT	ATE	X	151,3	50	18	2A-2B	2	200
-------------	------	-----	---	-------	----	----	-------	---	-----



0824	FORD	ATE	X	177,8	A 58,7 B 60,9	19	2A-2B		
-------------	------	-----	---	-------	------------------	----	-------	--	--

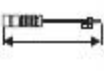

									
0825	HYUNDAI	MANDO	X	104,8	41,6	15,2	2A 1B-1C		

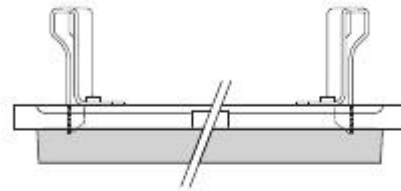
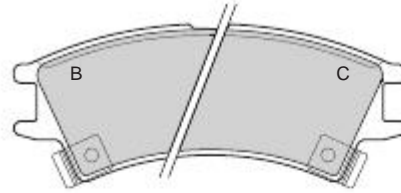
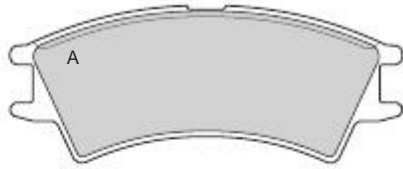



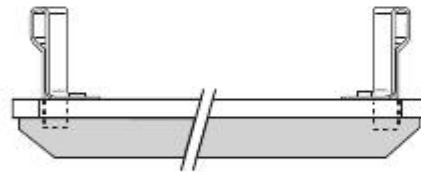
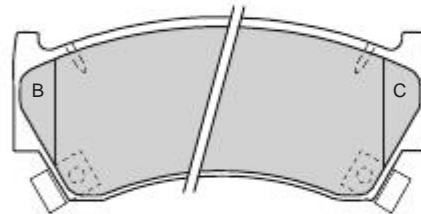
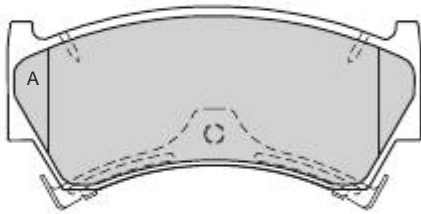



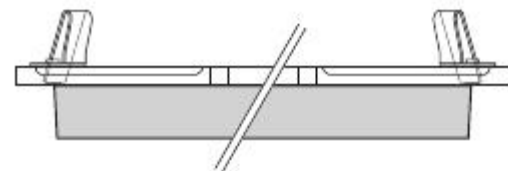
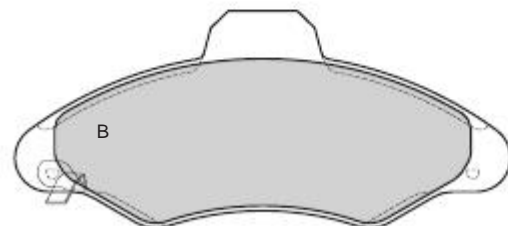
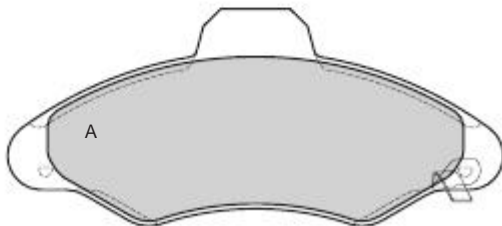



0826	NISSAN	SUMITOMO	X	108,5	48	15,5	2A 1B-1C		
-------------	--------	----------	---	-------	----	------	-------------	--	--



0827	FORD	BENDIX	X	130,9	57,7	18,8	2A-2B		
-------------	------	--------	---	-------	------	------	-------	--	--



									
0828	HYUNDAI	MANDO	X	147,8	52,6	16	2A-2B		

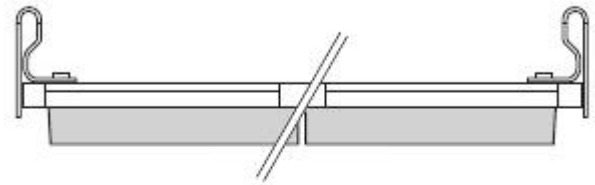
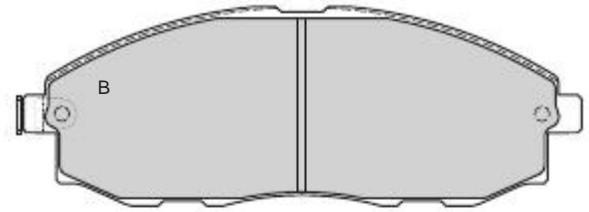
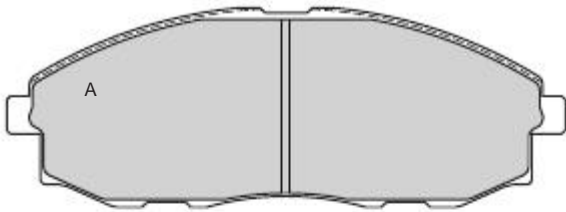



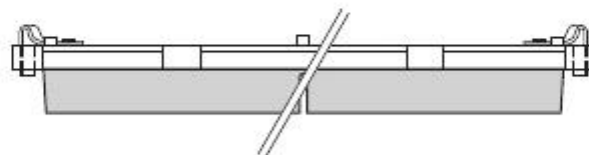
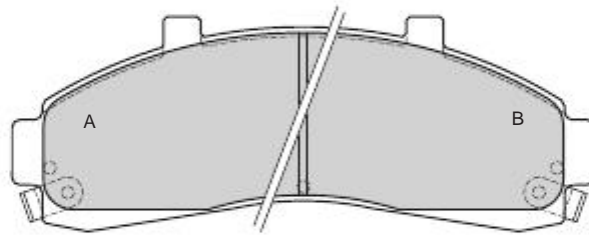



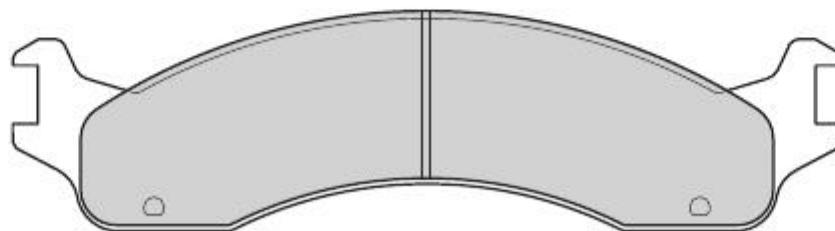



0829	FORD USA	WAGNER	X	154	57	16,8	2A-2B		
-------------	----------	--------	---	-----	----	------	-------	--	--



0830	FORD USA	KELSEY-HAYES	X	220	58	15	4		
-------------	----------	--------------	---	-----	----	----	---	--	--



									
0831	LEXUS - TOYOTA	SUMITOMO	X	122	41	15.5	2A-2B		

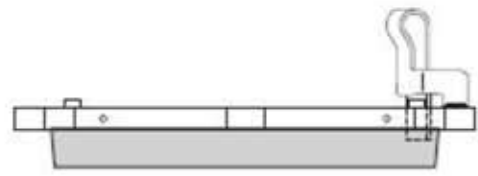



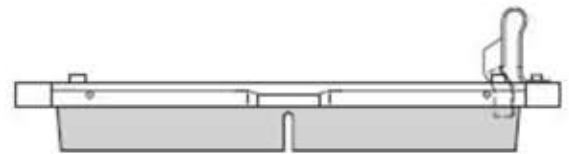
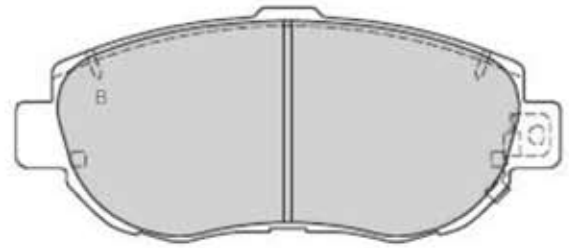
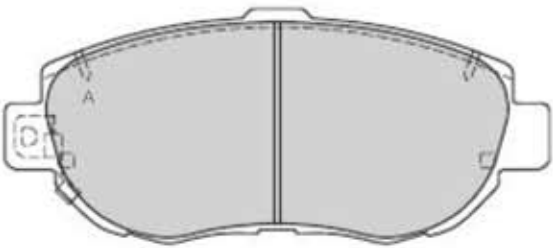



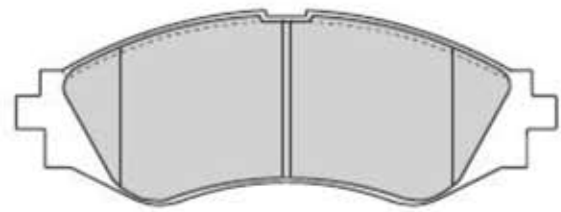

0832	LEXUS - TOYOTA	SUMITOMO	X	144	63.8	17.8	2A-2B		
------	----------------	----------	---	-----	------	------	-------	--	--

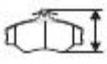

0833	DAEWOO	AKEBONO	X	143	51.5	16.8	4		
------	--------	---------	---	-----	------	------	---	--	--

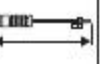

									
0834	DAEWOO	AKEBONO	X	143	51,5	16,8	2A 1B-1C		

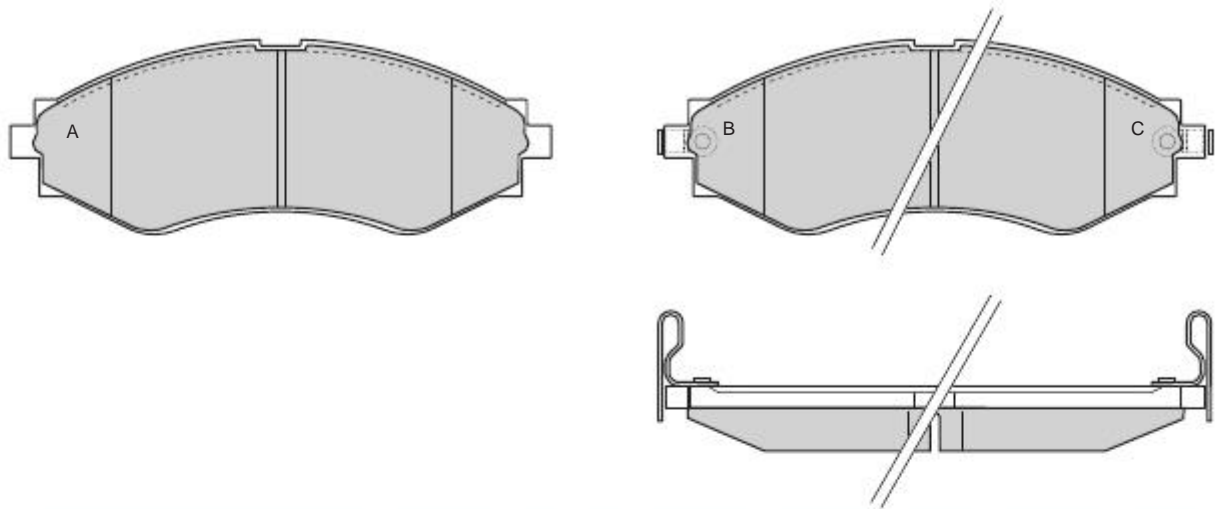



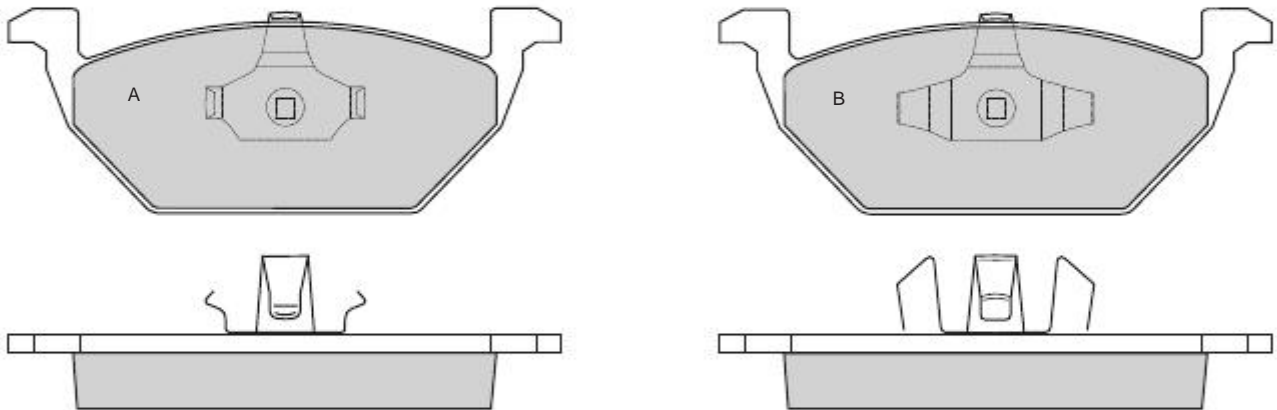



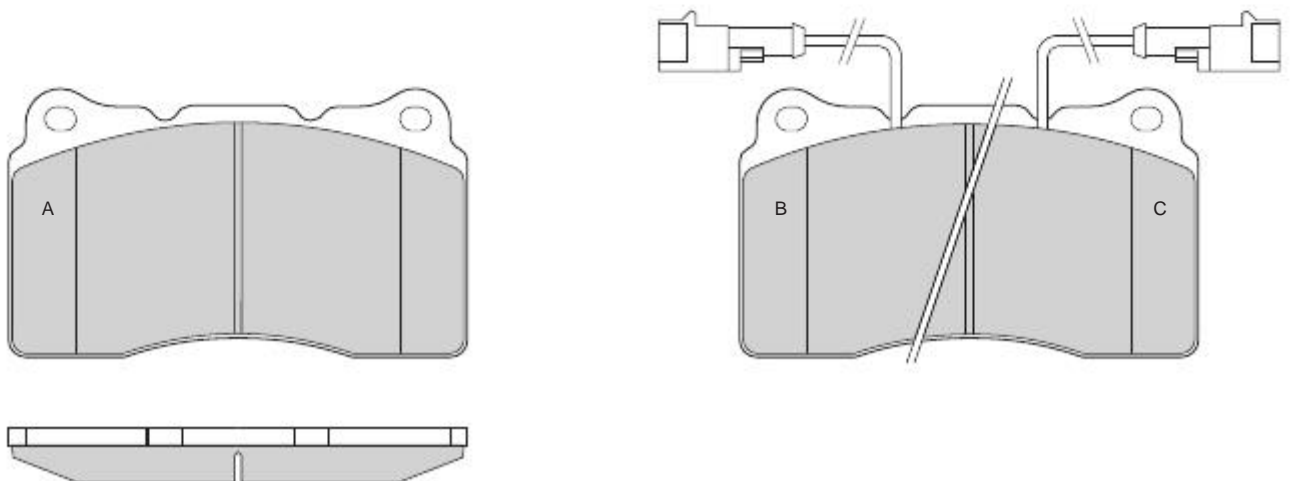



0835	AUDI - SEAT - SKODA VOLKSWAGEN	ATE	X	146	54,7	19,2	2A-2B		
-------------	-----------------------------------	-----	---	-----	------	------	-------	--	--



0836	ALFA ROMEO - LANCIA	BREMBO	X	131,8	77,3	15	2A 1B-1C	2	230
-------------	---------------------	--------	---	-------	------	----	-------------	---	-----



									
0837	CHRYSLER - DODGE PLYMOUTH	BENDIX	X	176,9	46,9	A 16 B-C 15	2A 1B-1C		

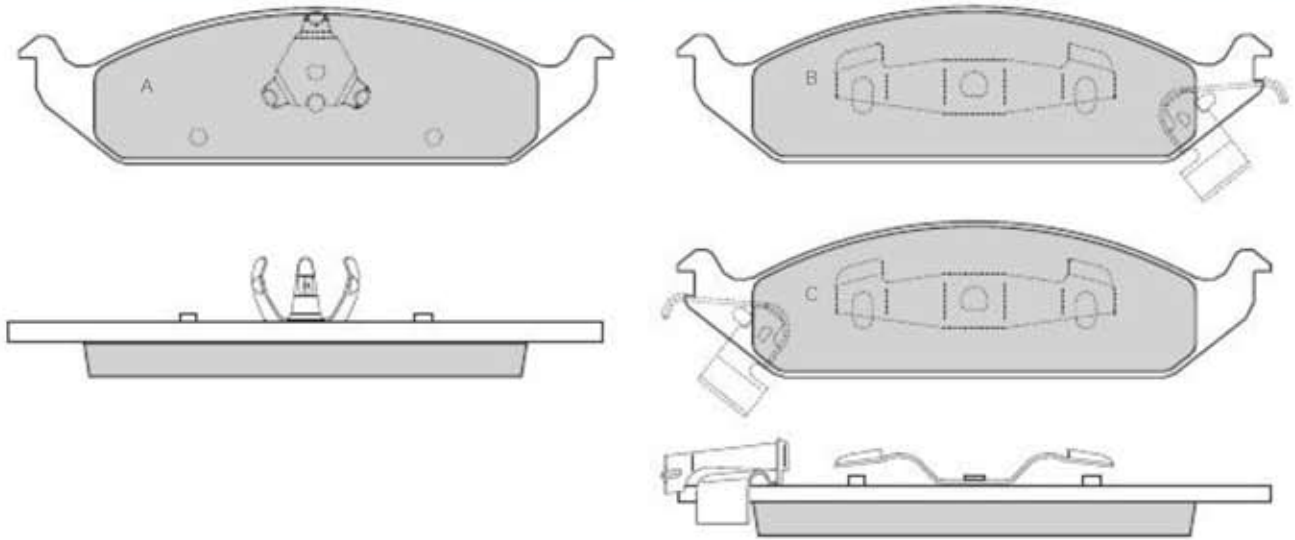



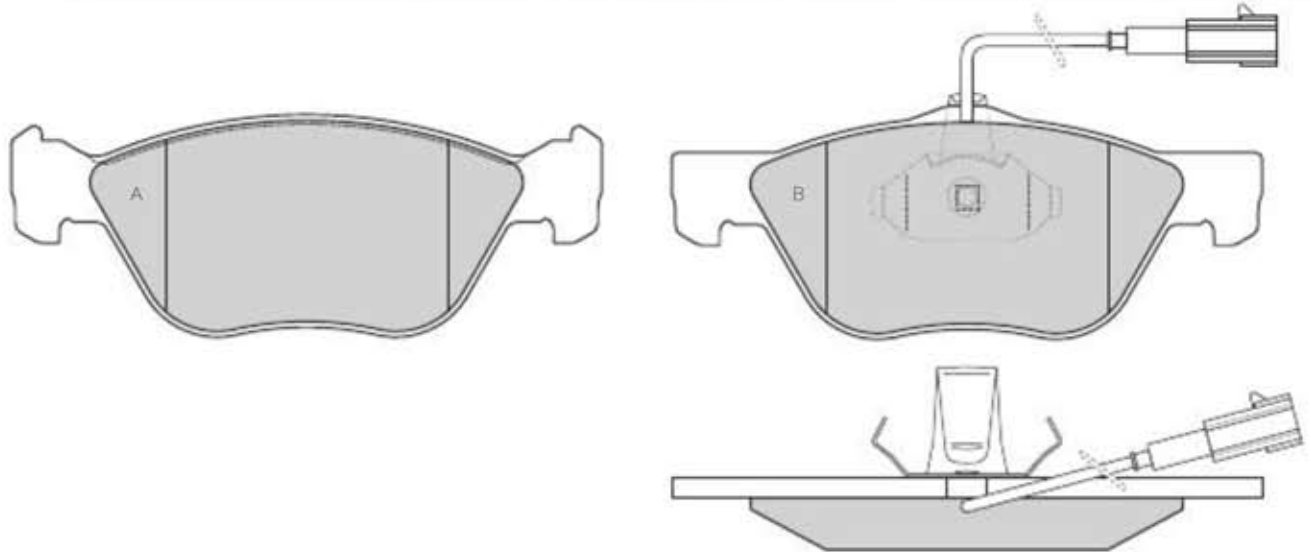



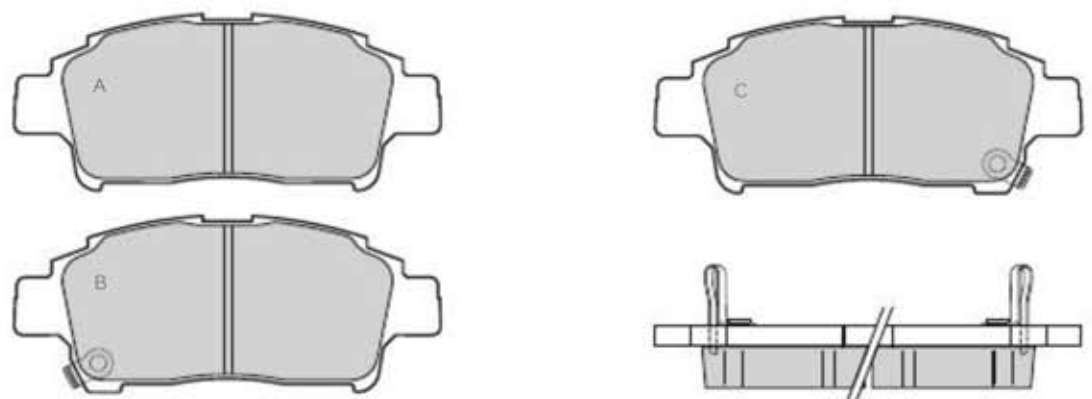



0838	ALFA ROMEO - LANCIA	ATE	X	A 156,4 B 155,2	A 59 B 61,8	19	2A-2B	2	220
------	---------------------	-----	---	--------------------	----------------	----	-------	---	-----



0839	TOYOTA	AKEBONO	X	112,7	46,7	16,5	2A 1B-1C		
------	--------	---------	---	-------	------	------	-------------	--	--



									
0840	FORD USA	WAGNER	X	A 160,2 B 172	A 62,6 B 63,6	A 15 B 14	2A-2B		

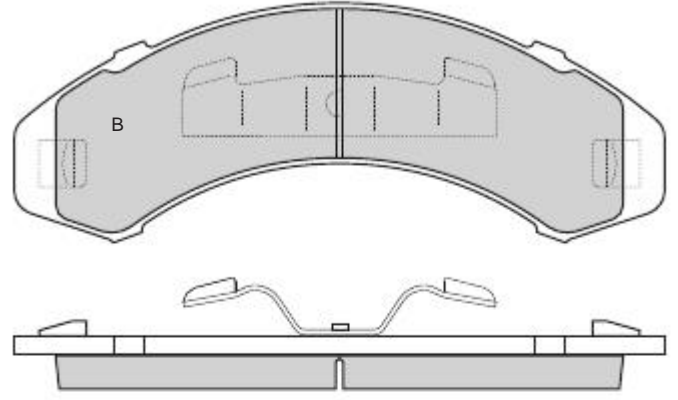
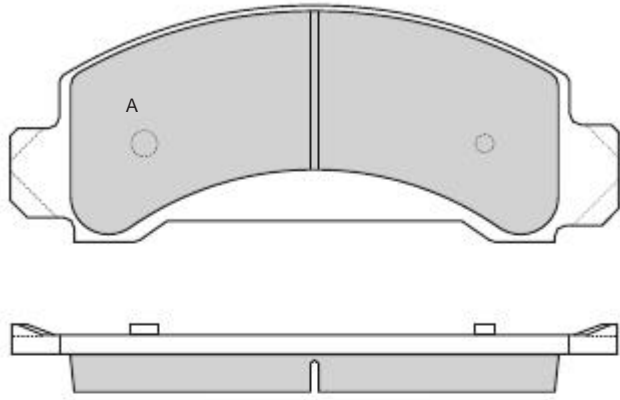



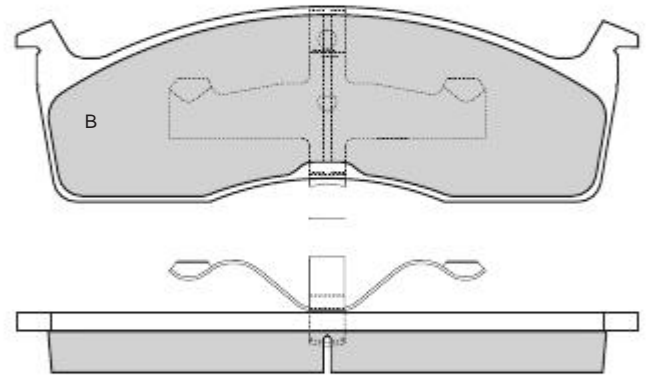
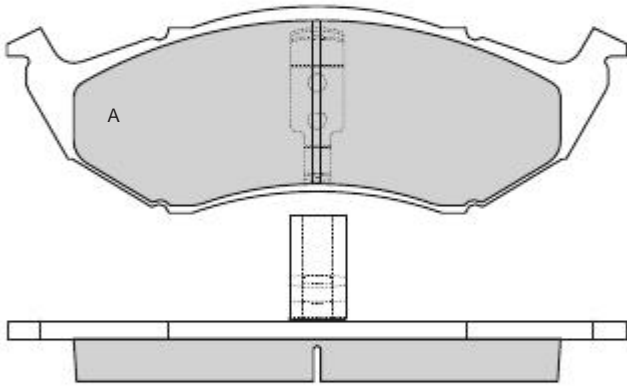



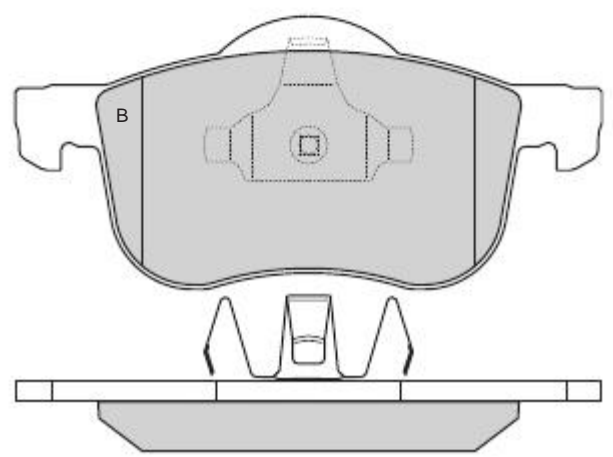



0841	CHRYSLER - DODGE EAGLE - PLYMOUTH	KELSEY-HAYES	X	A 164,1 B 164,7	A 54,8 B 51,6	16	2A-2B		
------	--------------------------------------	--------------	---	--------------------	------------------	----	-------	--	--



0842	VOLVO	ATE	X	A 156,6 B 155,3	A 69 B 72,4	18,6	2A-2B		
------	-------	-----	---	--------------------	----------------	------	-------	--	--



									
0843	VOLVO	ATE	X	A 123,8 B 122,7	53,7	17,5	2A-2B		

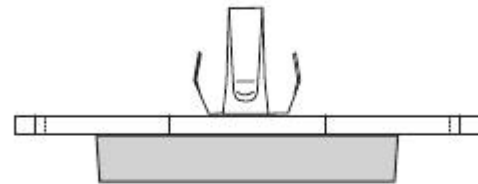
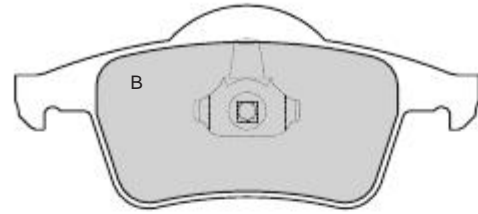



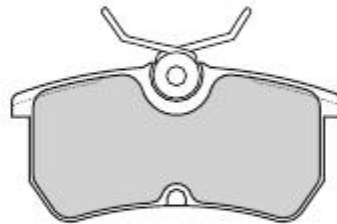



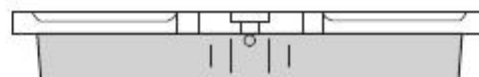
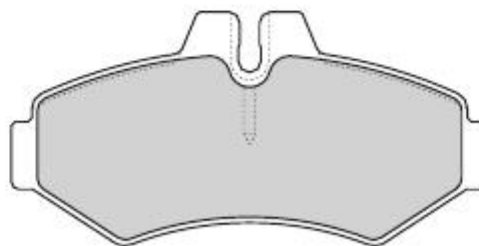



0844	FORD	GIRLING	X	87,2	42,5	14,5	4		
-------------	------	---------	---	------	------	------	---	--	--



0845	MERCEDES VOLKSWAGHEN	PERROT	X	126	61,3	17,8	4		
-------------	-------------------------	--------	---	-----	------	------	---	--	--



									
0846	SUBARU - SUZUKI	BOSCH	X	130.9	44.5	15	A-1B 1C-1D		

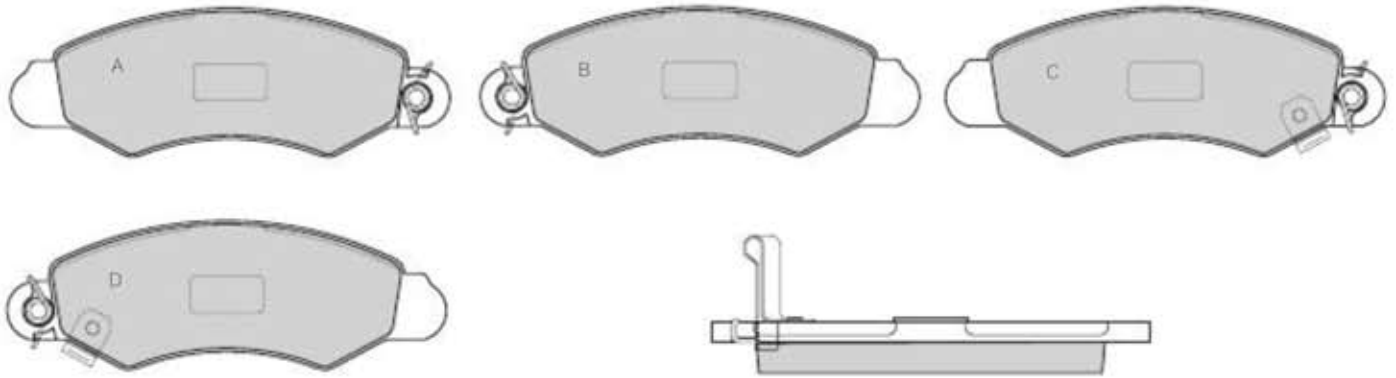



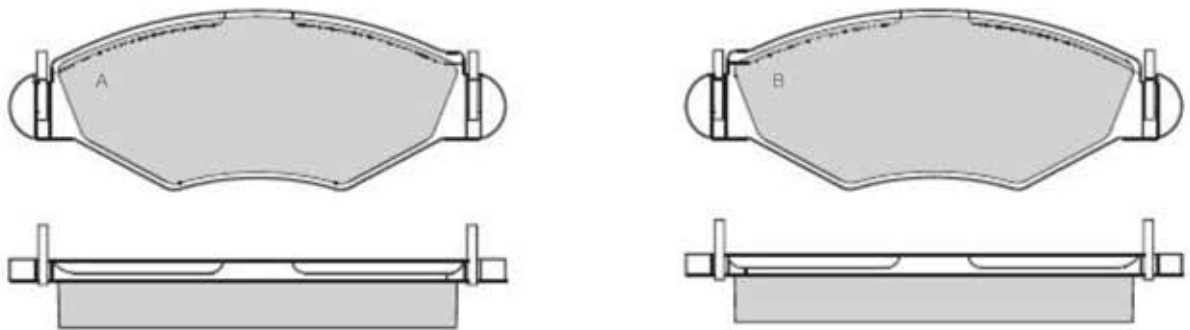



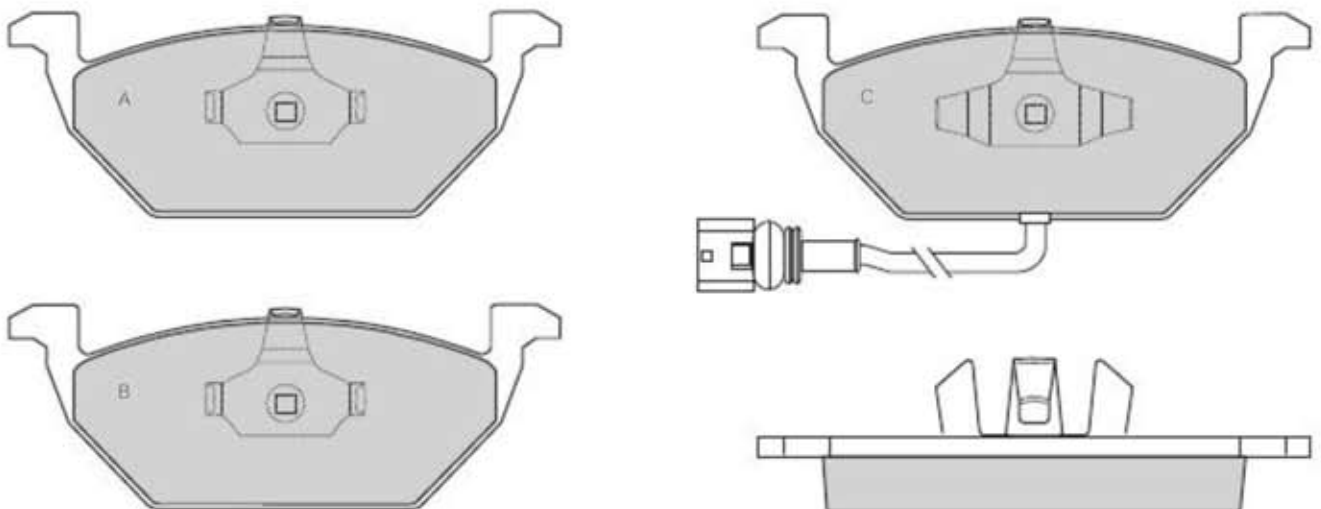

0847	PEUGEOT	BOSCH	X	131	47.3	18	2A-2B		
------	---------	-------	---	-----	------	----	-------	--	--



0848	AUDI - SEAT - SKODA VOLKSWAGEN	ATE	X	146	54.7	19.2	2A 1B-1C	T	140
------	-----------------------------------	-----	---	-----	------	------	-------------	---	-----

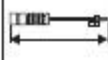

									
0849	RENAULT	GIRLING	X	130,1	55,8	18,5	3A-1B	1	305

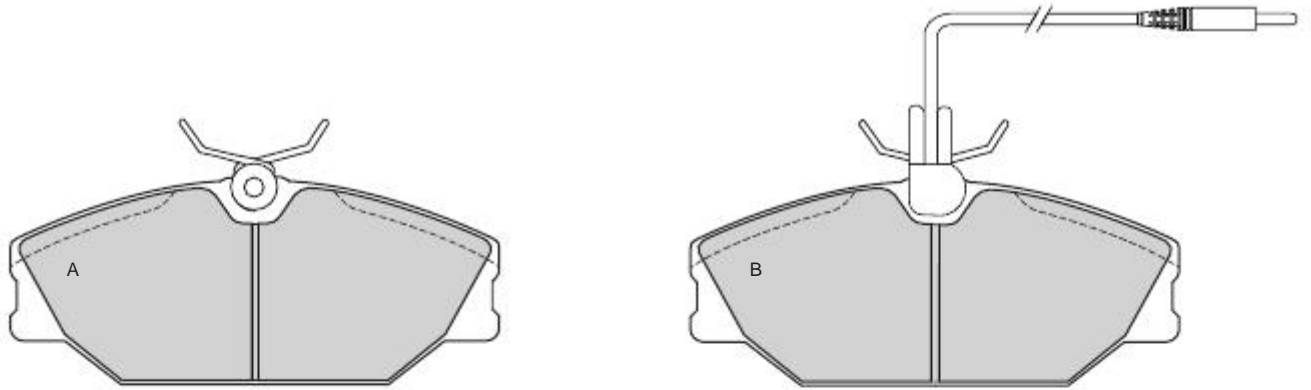



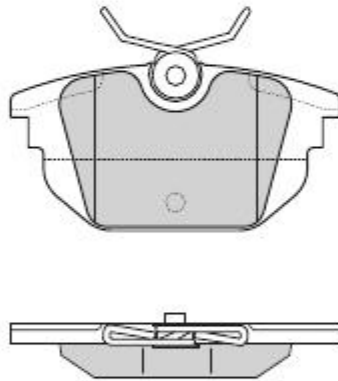



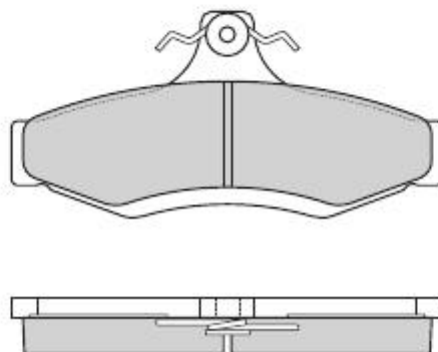



0850	ALFA ROMEO - FIAT LANCIA	GIRLING	X	87,3	44,4	14,4	4		
-------------	-----------------------------	---------	---	------	------	------	---	--	--



0851	DAEWOO	GIRLING	X	114	54,9	14,5	4		
-------------	--------	---------	---	-----	------	------	---	--	--



									
0852	CITROEN	CITROEN		37	146	10,7	2		

FRENO A MANO

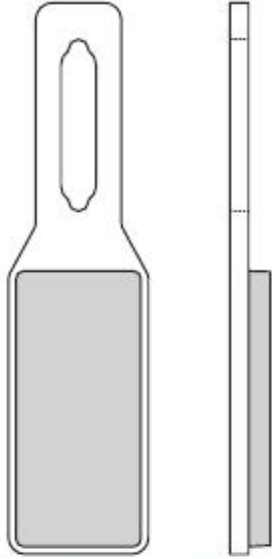



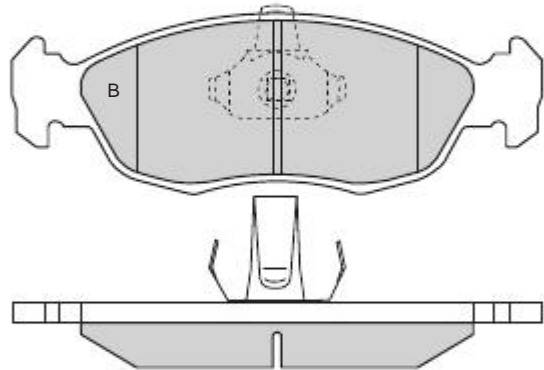
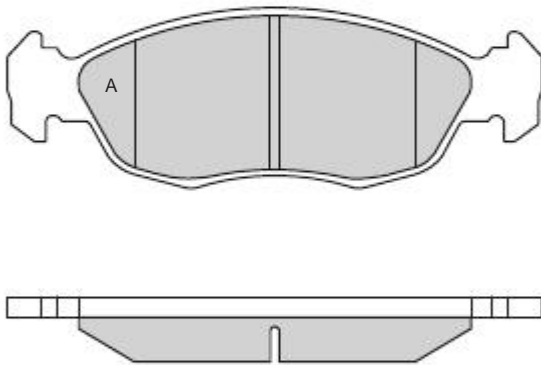



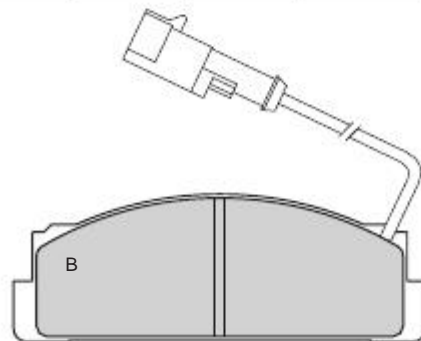
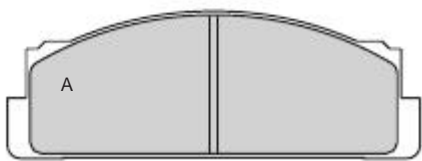

0853	PEUGEOT	ATE	X	A 141,5 B 140,25	A 47,6 B 47,45	17,3	2A-2B		
-------------	---------	-----	---	---------------------	-------------------	------	-------	--	--



0854	FIAT TURCHIA	BENDIX	X	109	39	17,5	3A-1B	1	230
-------------	--------------	--------	---	-----	----	------	-------	---	-----

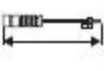

									
0855	JEEP	ATE	X	A 141,5 B 139,5	A 59 B 55	17,8	2A-2B		

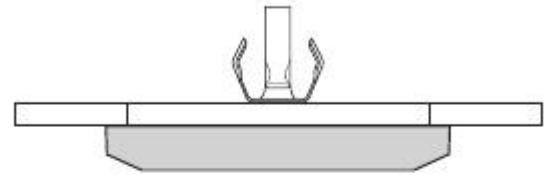
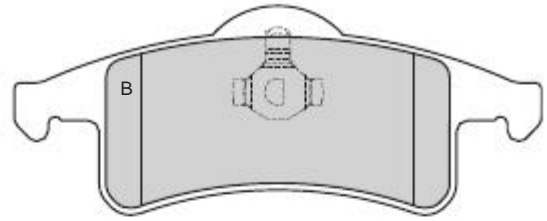
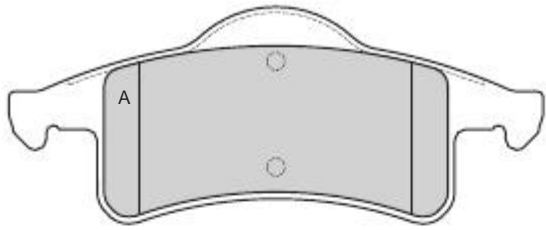



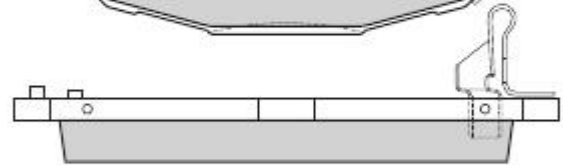
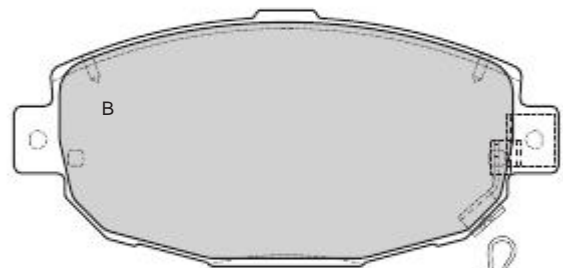
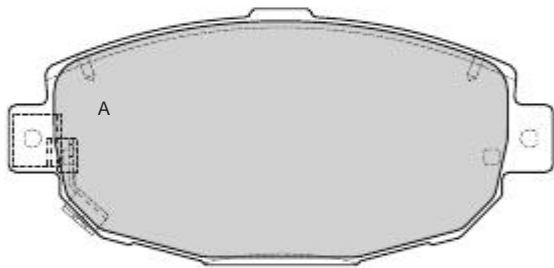



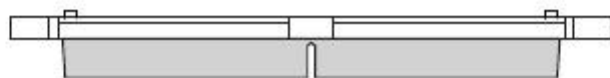
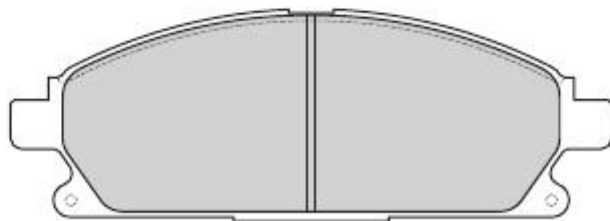



0856	LEXUS	AKEBONO	X	144,1	67,5	17	2A-2B		
------	-------	---------	---	-------	------	----	-------	--	--



0857	NISSAN	SUMITOMO	X	159	55,9	16	4		
------	--------	----------	---	-----	------	----	---	--	--



									
0858	TOYOTA - LEXUS	SUMITOMO	X	115,8	74,6	17	4		

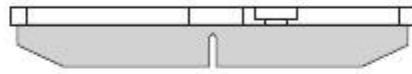
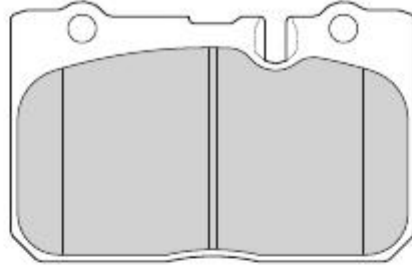



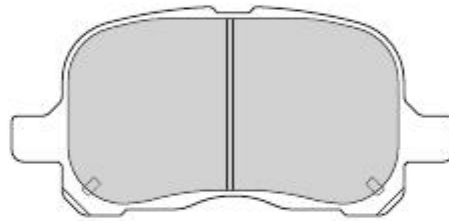



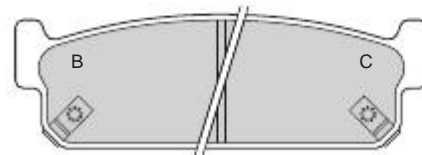

0859	TOYOTA	AKEBONO	X	116,85	55,2	16,5	4		
-------------	--------	---------	---	--------	------	------	---	--	--



0860	NISSAN	SUMITOMO	X	108,7	35,3	15	2A 1B-1C		
-------------	--------	----------	---	-------	------	----	-------------	--	--

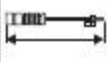

									
0861	MERCEDES	ATE	X	62	72,8	15	4		





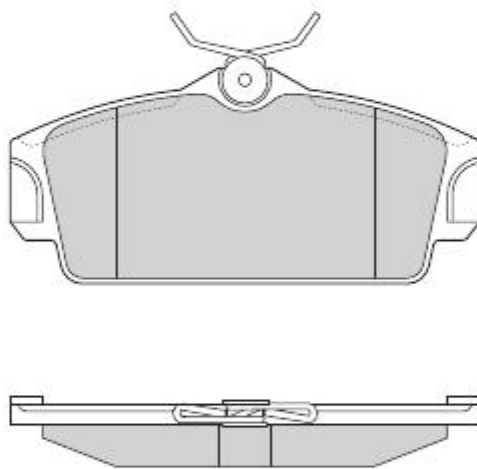



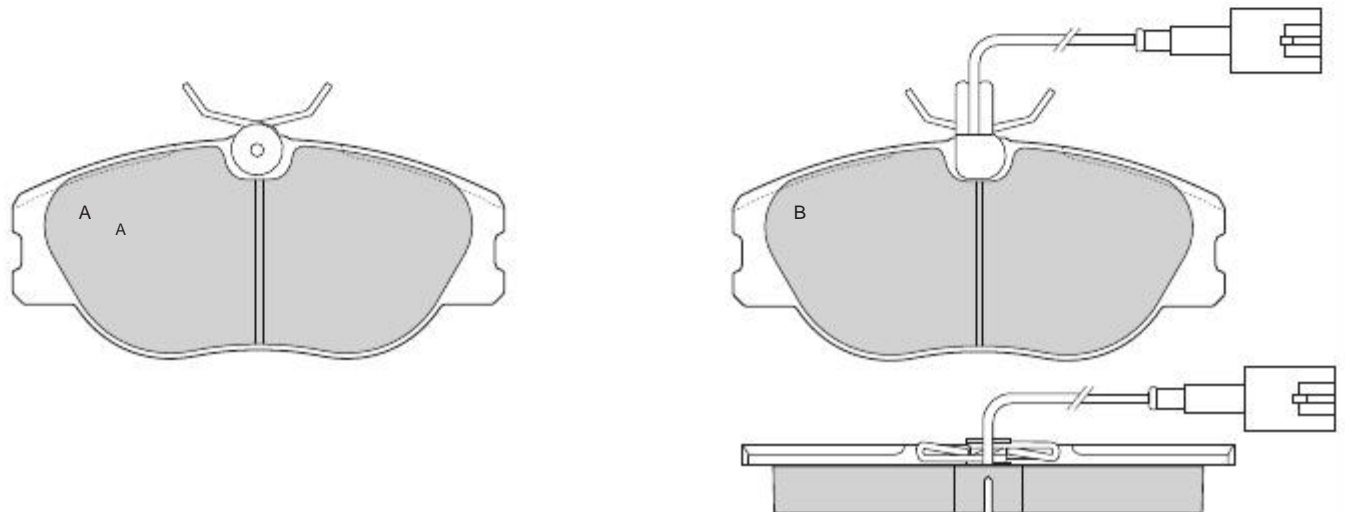

0862	NISSAN	GIRLING	X	123,95	57,3	16,6	4		
------	--------	---------	---	--------	------	------	---	--	--



0863	LANCIA	GIRLING	X	129,9	56,6	18,2	2A-2B	2	240
------	--------	---------	---	-------	------	------	-------	---	-----

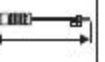

									
0864	MAZDA	SUMITOMO	X	131,7	51,5	A 15 B 16	2A 1B-1C		

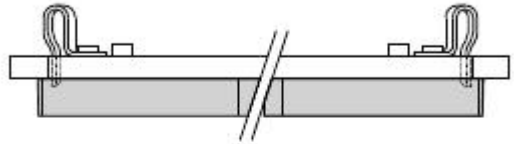
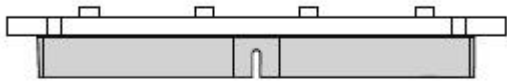
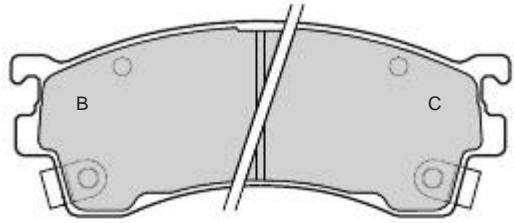
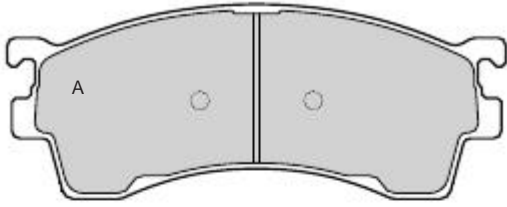



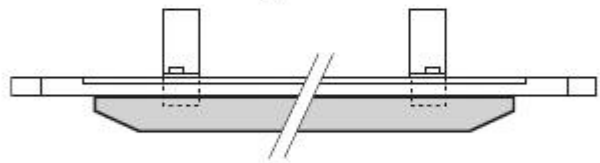
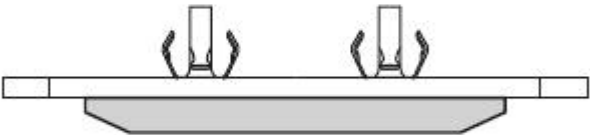
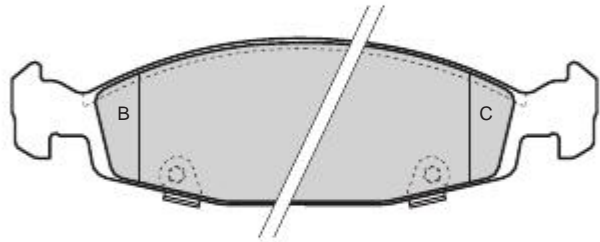
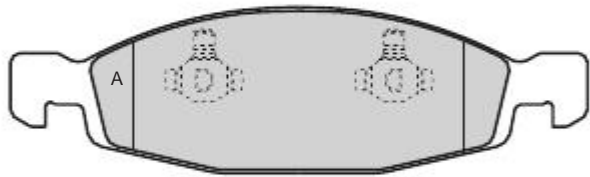





0865	JEEP	KELSEY-HAYES	X	A 192,2 B-C 194,2	55,4	18	2A 1B-1C		
------	------	--------------	---	----------------------	------	----	-------------	--	--



0866	VOLKSWAGEN	LUCAS	X	94,9	57,4	16	4		
------	------------	-------	---	------	------	----	---	--	--

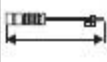

									
0867	SEAT - VOLKSWAGEN	LUCAS	X	94,9	57,4	16	2A-2B	2	210

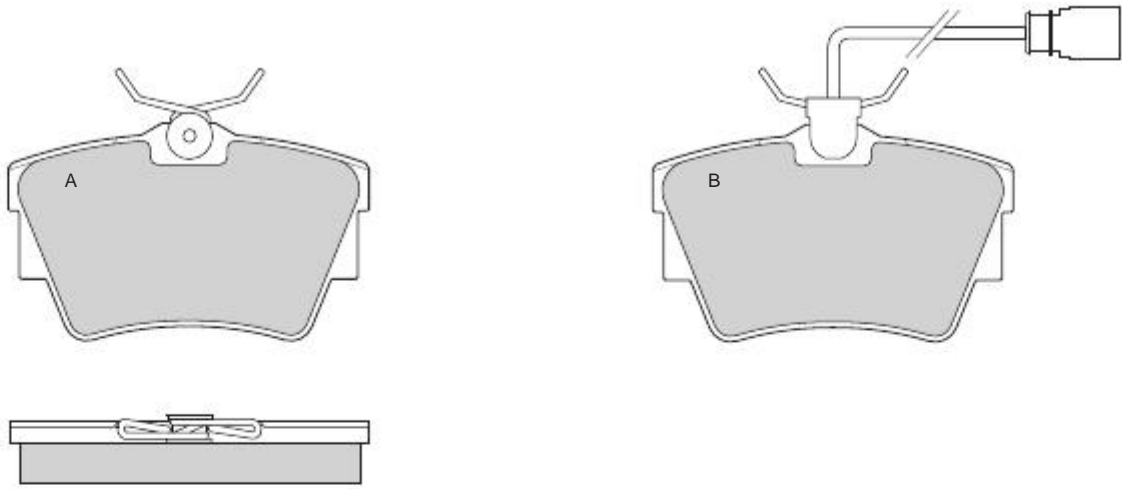



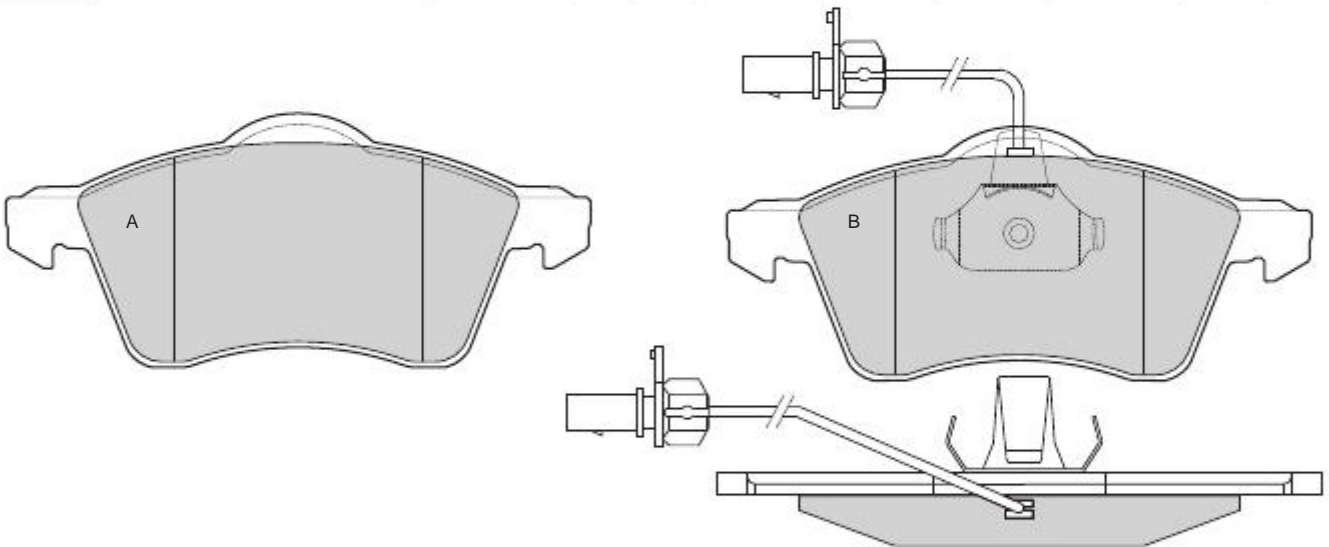



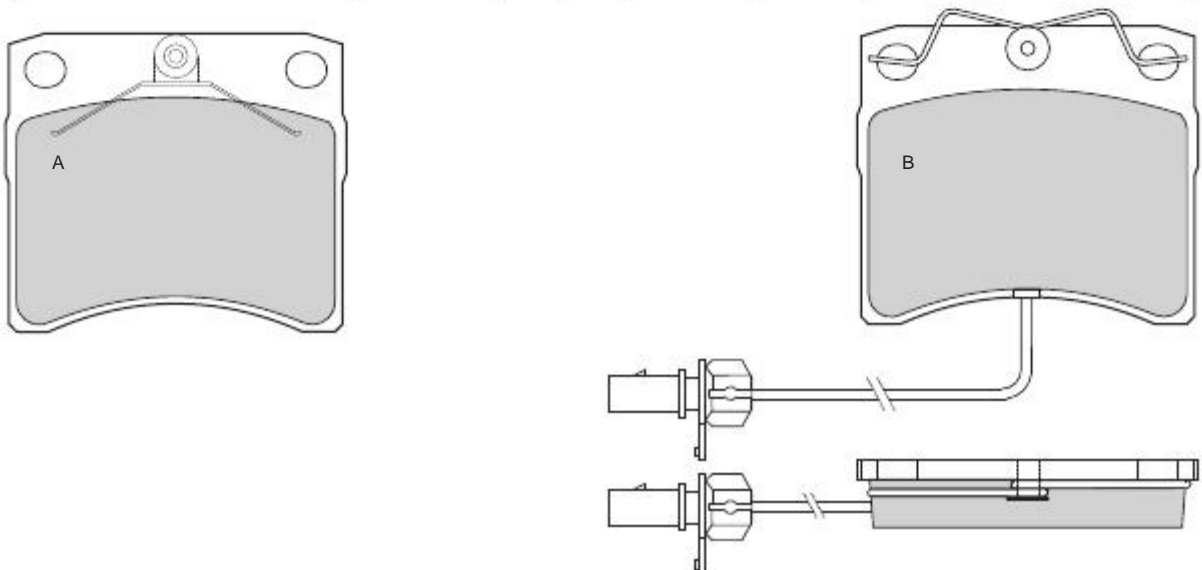

0868	VOLKSWAGEN	ATE	X	156,4	68,5	19,6	2A-2B	2	210
------	------------	-----	---	-------	------	------	-------	---	-----



0869	VOLKSWAGEN	LUCAS	X	91,4	80	18	2A-2B	2	215
------	------------	-------	---	------	----	----	-------	---	-----

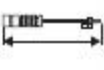

									
0870	HONDA - NISSAN - ROVER	SUMITOMO	X	131,6	58,6	17,2	2A 1 B - 1C		

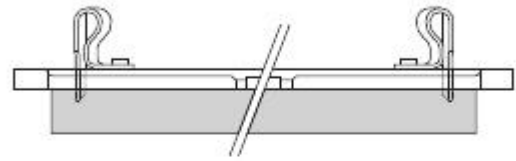
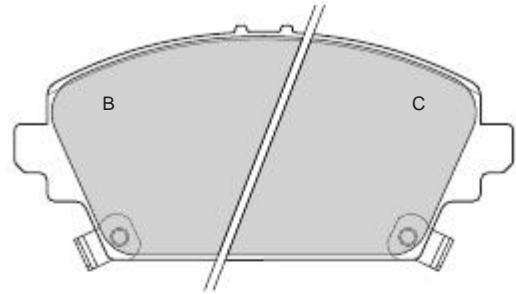
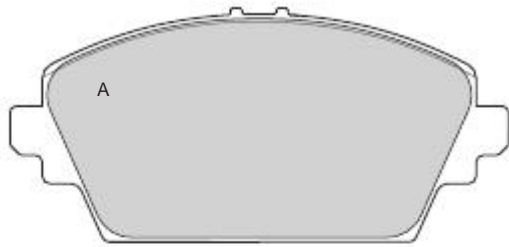



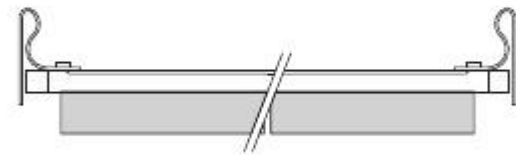
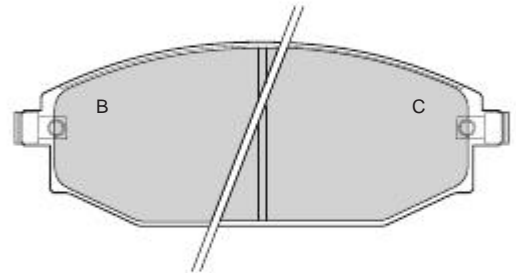
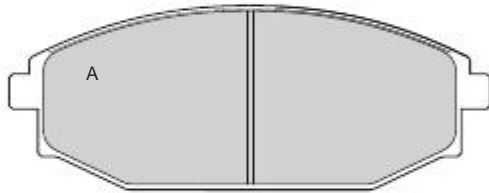



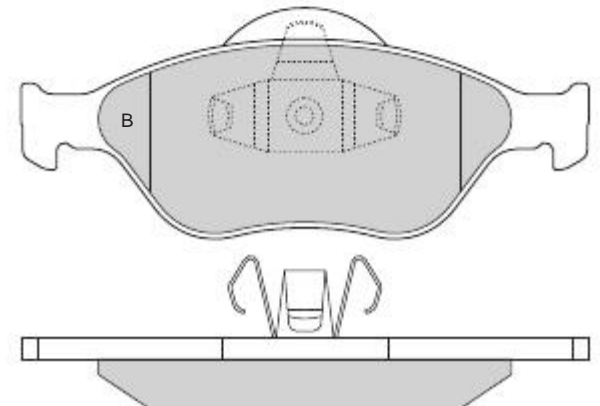
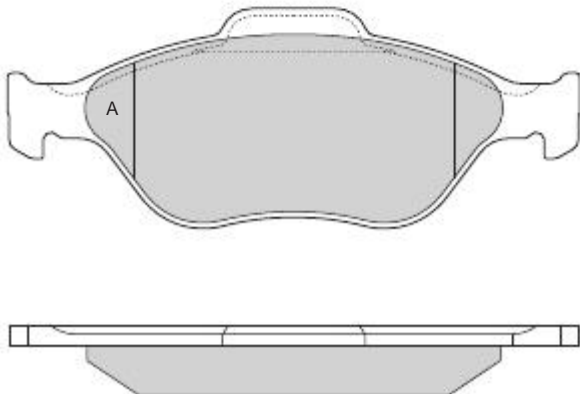



0871	HYUNDAI	SUMITOMO	X	137	52,5	18	2A 1B-1C		
------	---------	----------	---	-----	------	----	-------------	--	--



0872	FORD	ATE	X	A 151,3 B 150	A 61 B 58,20	18,8	2A-2B		
------	------	-----	---	------------------	-----------------	------	-------	--	--



									
0873	FORD	ATE	X	A 151,3 B 150	A 51,2 B 54	18,8	2A-2B		

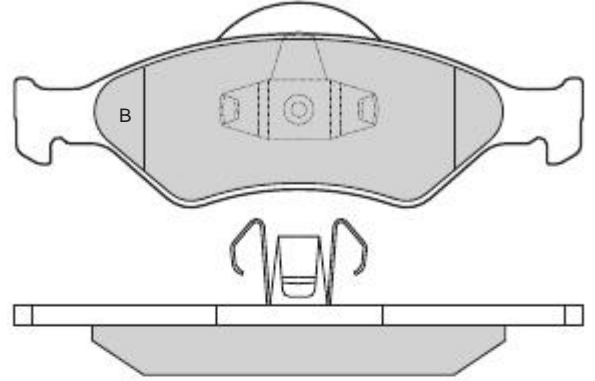
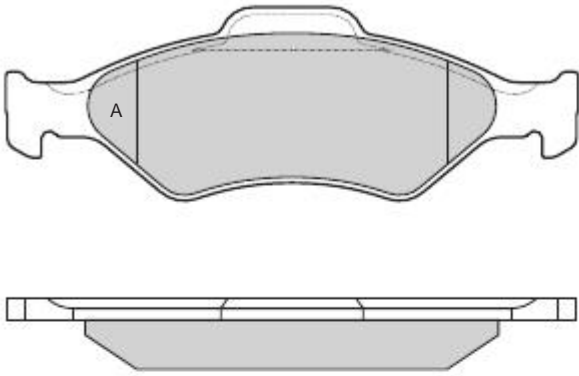



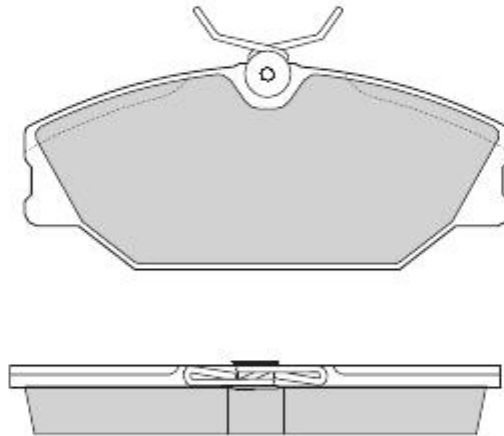



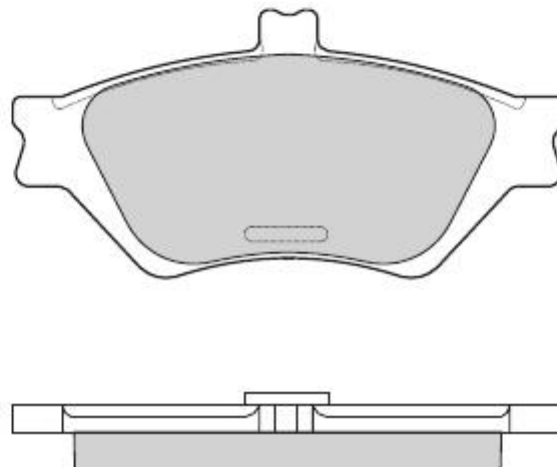

0874	RENAULT	LUCAS	X	129,1	55,8	18	4		
------	---------	-------	---	-------	------	----	---	--	--



0875	FORD - LINCOLN - MERCURY	BENDIX	X	144,6	70,9	16,8	4		
------	--------------------------	--------	---	-------	------	------	---	--	--

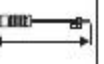

									
0876	OPEL - BUICK - CADILLAC CHEVROLET - OLDSMOBILE	WAGNER	X	147,5	61,7	17	2A 1B-1C		

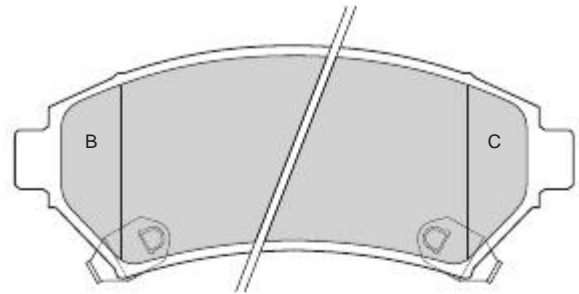
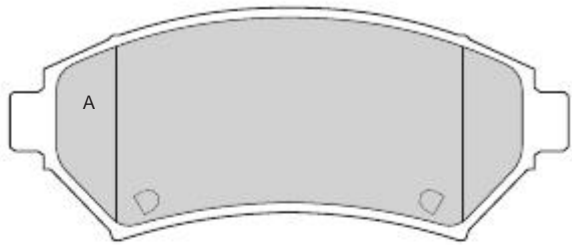



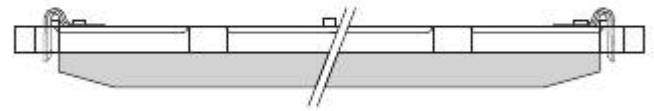
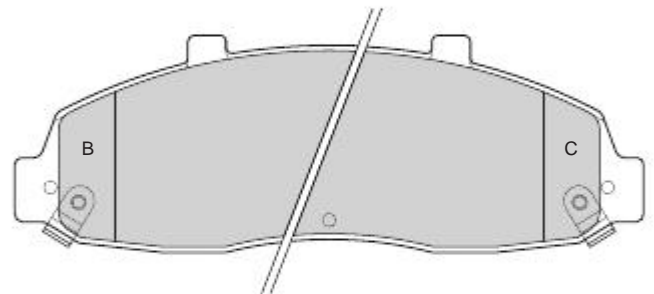
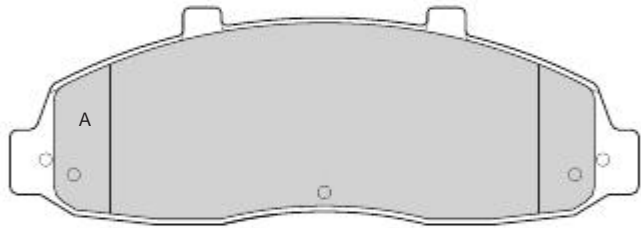



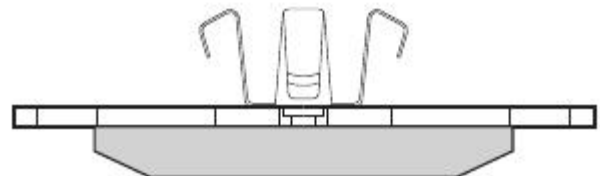
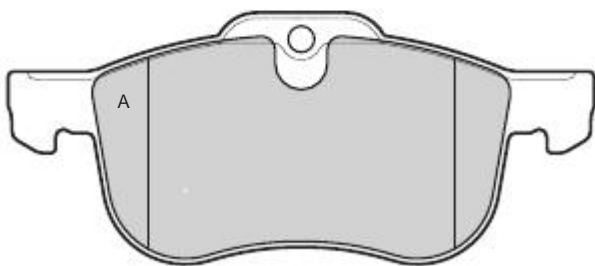

0877	FORD TRUCK	WAGNER	X	166,1	57,2	16	2A 1B-1C		
------	------------	--------	---	-------	------	----	-------------	--	--



0878	ROVER	ATE	X	A 156,3 B 155	A 62,4 B 70,4	19	2A-2B		
------	-------	-----	---	------------------	------------------	----	-------	--	--

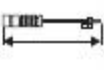

									
0879	CITROEN - PEUGEOT	BOSCH	X	130,9	52,2	18	2A-2B		

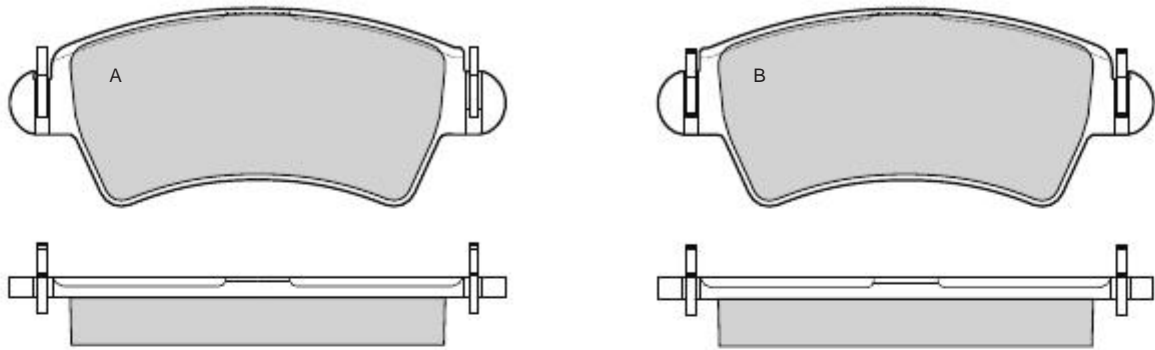



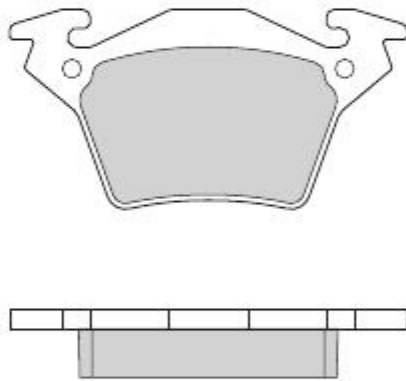



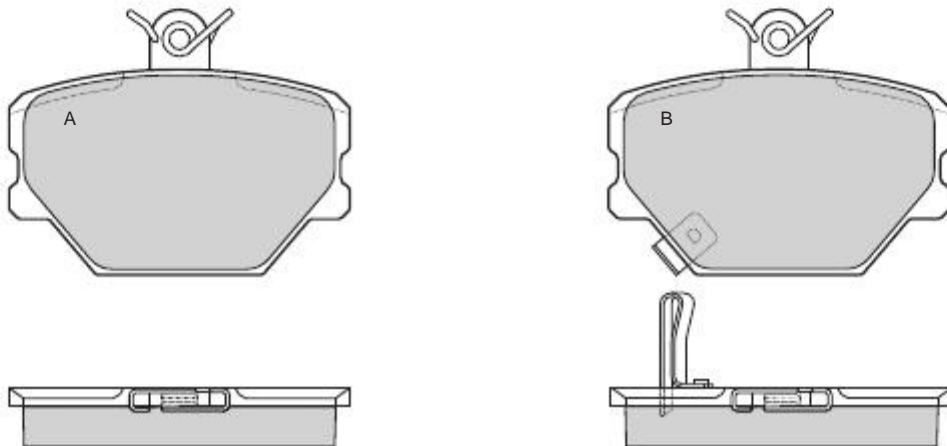

0880	MERCEDES	BOSCH	X	104,9	52,6	17,9	4		
-------------	----------	-------	---	-------	------	------	---	--	--



0881	MERCEDES - SMART	BOSCH	X	90	70,1	15,5	2A-2B		
-------------	------------------	-------	---	----	------	------	-------	--	--

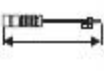

									
0882	CHEVROLET	SUMITOMO	X	161,2	A 57,7 B-C 62,8	A 16,2 B-C 16,8	2A 1B-1C		

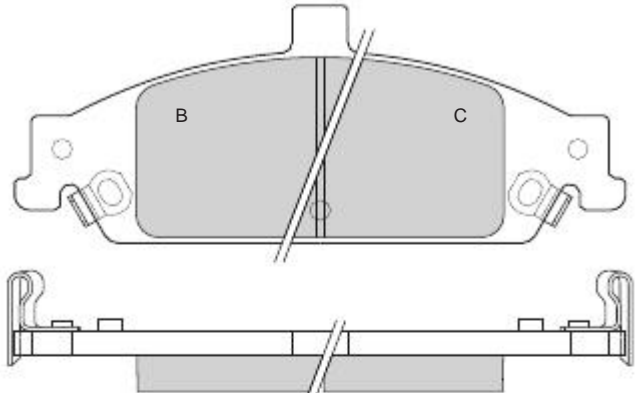
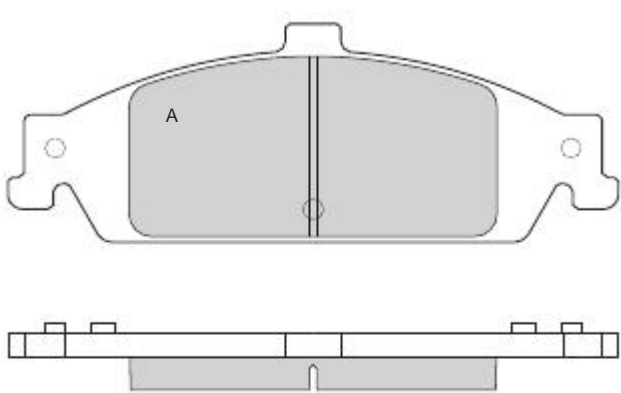



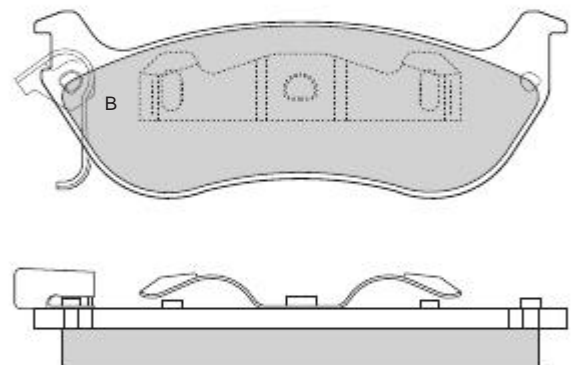
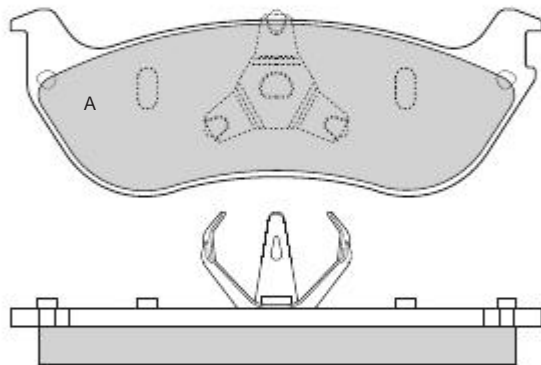



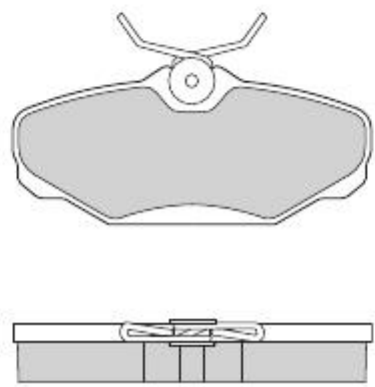

0883	MERCURY	KELSEY-HAYES	X	140,6	49,3	16	2A-2B		
------	---------	--------------	---	-------	------	----	-------	--	--



0884	FORD USA - LINCOLN MERCURY	GIR	X	94,5	41,7	15,5	4		
------	-------------------------------	-----	---	------	------	------	---	--	--

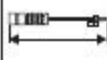

									
0885	CHEVROLET - DODGE	BENDIX	X	A 125,7 B 147,3	A 85,6 B-C 58,9	A 16 B-C 15,7	2A 1B-1C		

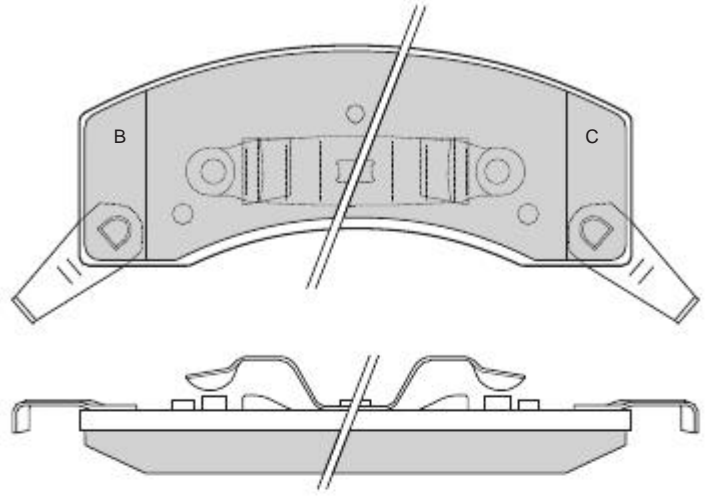
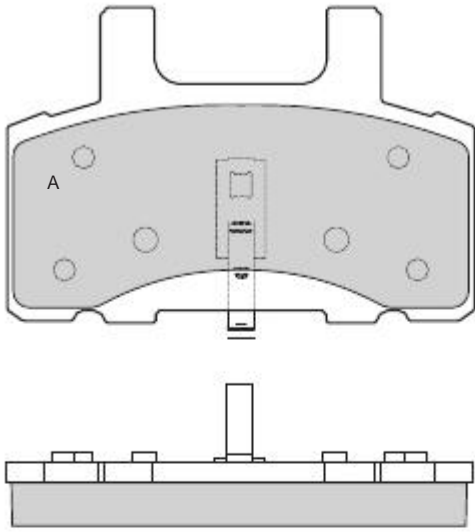



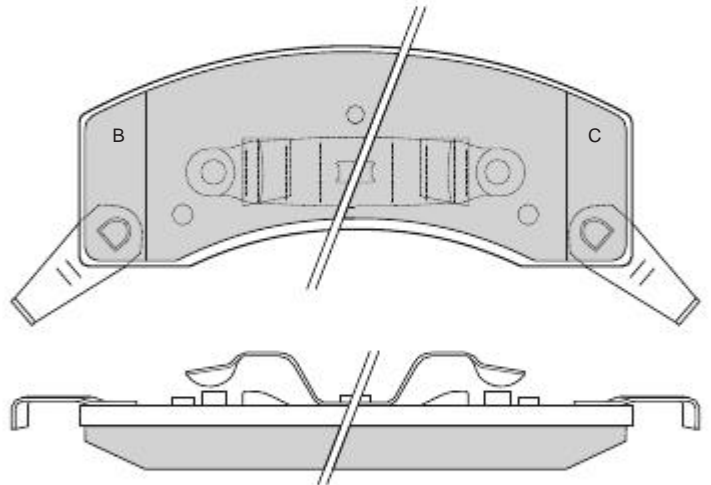
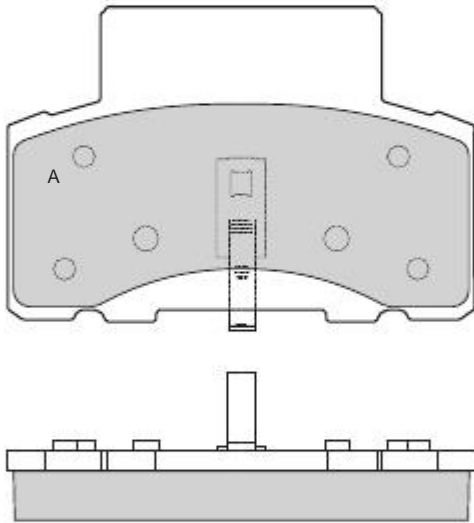



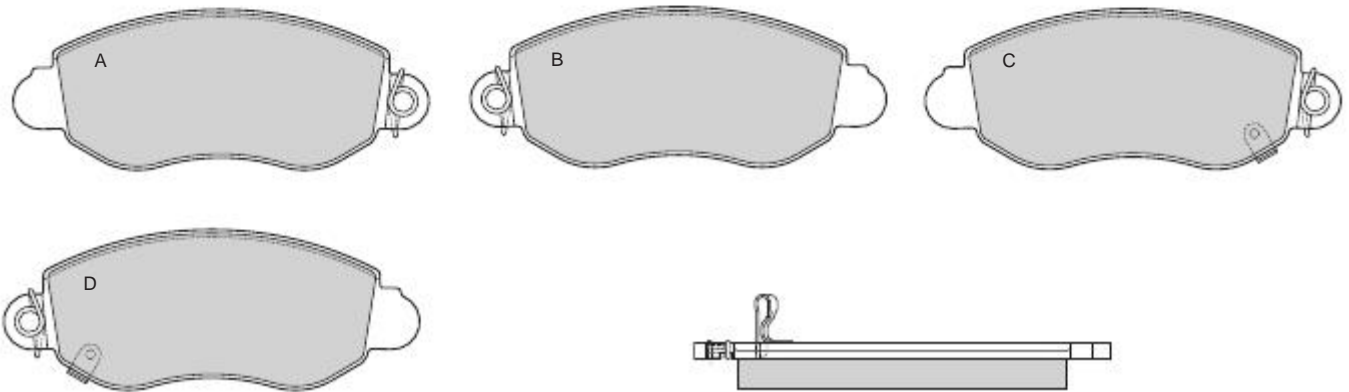



0886	CHEVROLET - DODGE - GMC	BENDIX	X	A 125,7 B-C 147,3	A 84,6 B-C 58,9	A 18,8 B-C 15,7	2A 1B-1C		
-------------	-------------------------	--------	---	----------------------	--------------------	--------------------	-------------	--	--



0887	FORD	BOSCH	X	168,4	65	18,5	1A-1B 1C-1D		
-------------	------	-------	---	-------	----	------	----------------	--	--



									
0888	CITROEN - FIAT	LUCAS	X	144,9	59	19,5	3A-1B	1	300

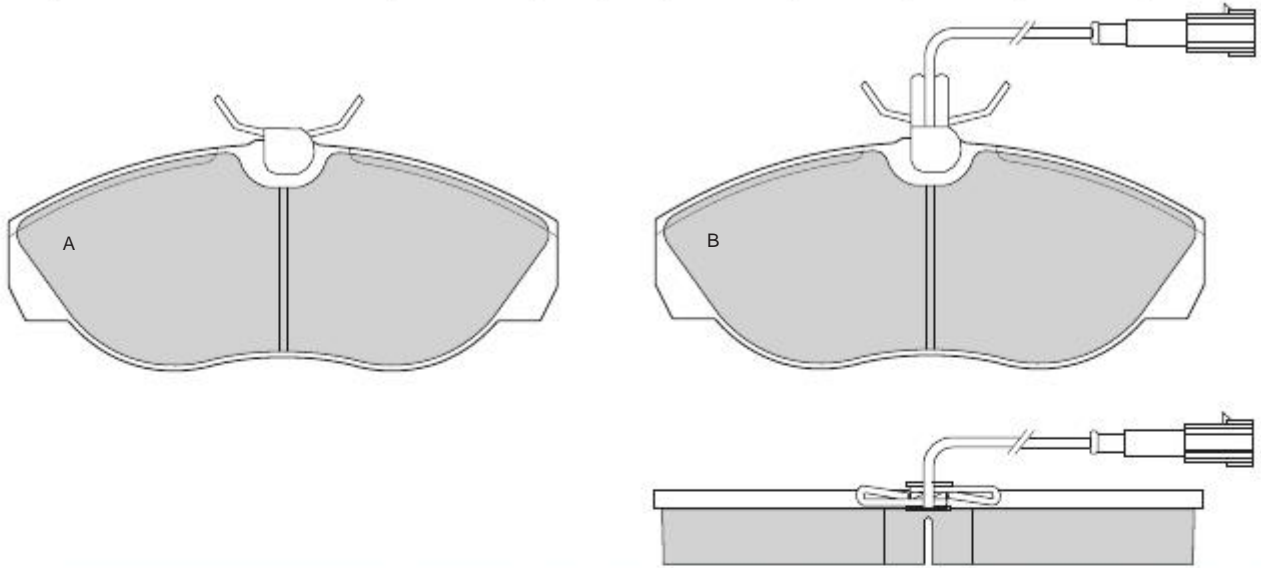



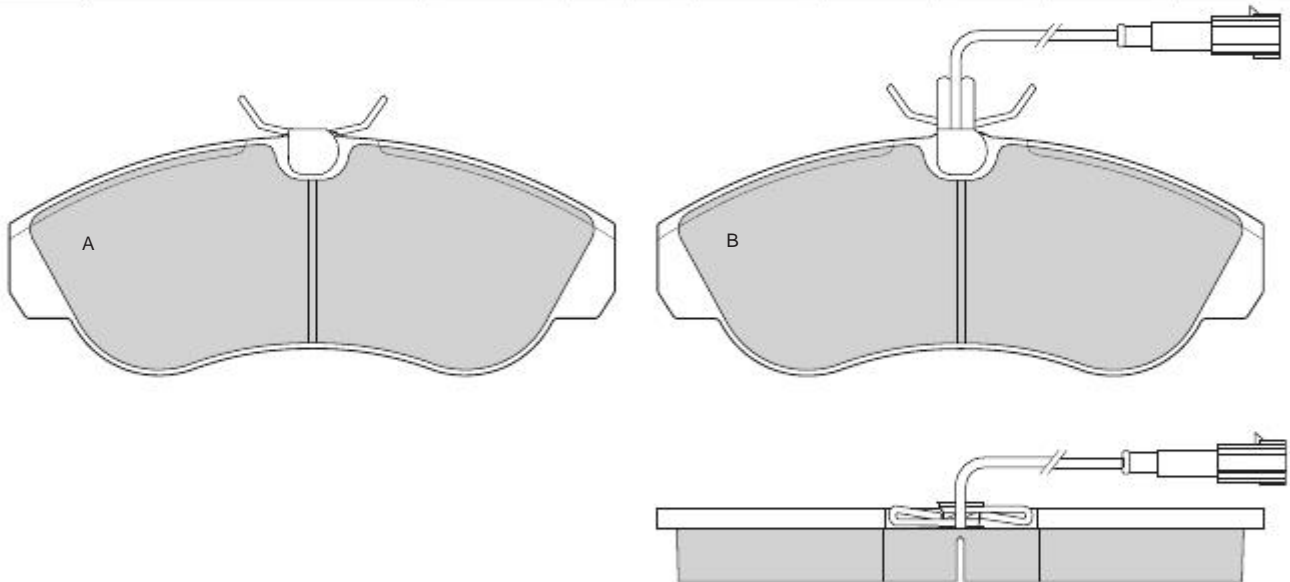



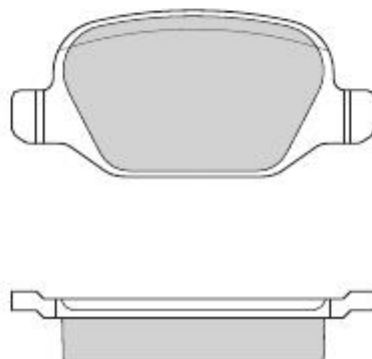



0889	CITROEN - FIAT	LUCAS	X	159,9	62,8	19,5	3A-1B	1	300
------	----------------	-------	---	-------	------	------	-------	---	-----



0890	ALFA ROMEO - LANCIA	GIRLING	X	95,8	43,9	16,5	4		
------	---------------------	---------	---	------	------	------	---	--	--



									
0891	FIAT	GIRLING	X	95,8	43,9	13	4		





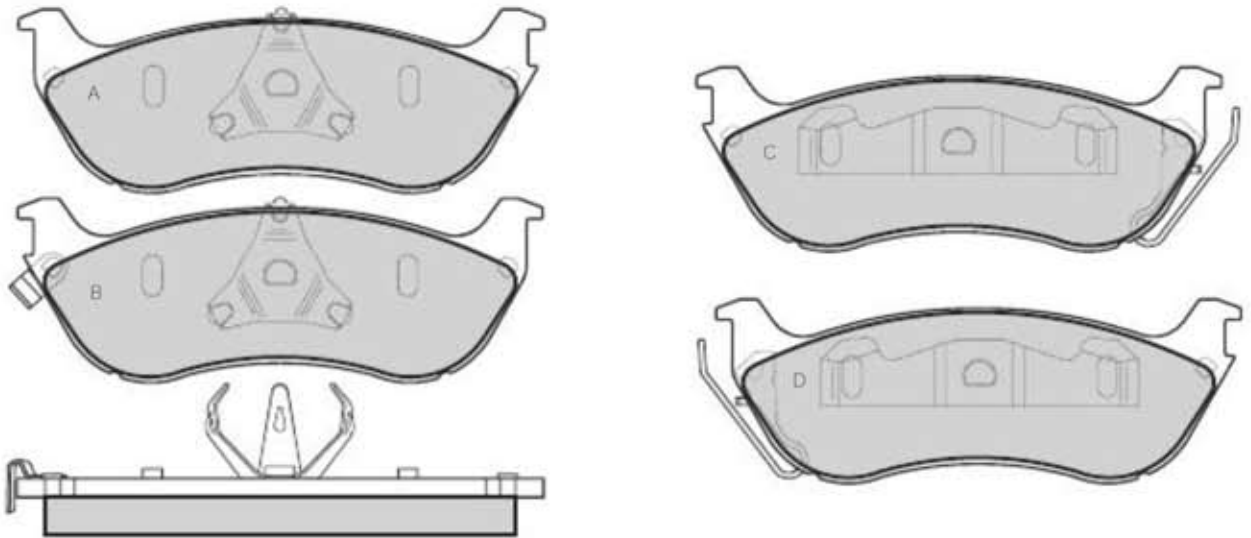



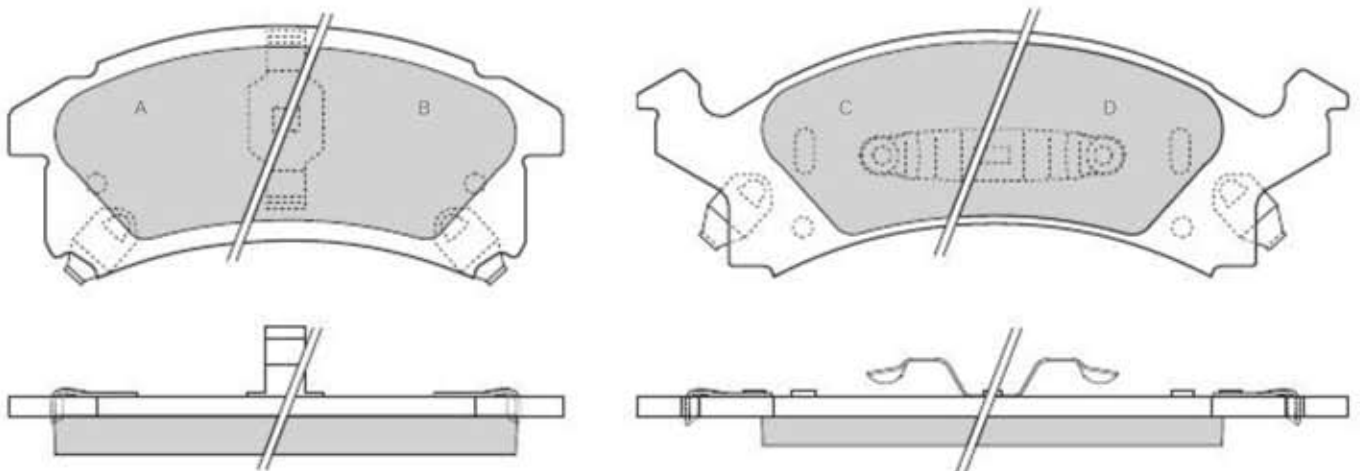



0892	MERCEDES	KELSEY-HAYES	X	140	50	16,6	1A-1B 1C-1D		
------	----------	--------------	---	-----	----	------	----------------	--	--



0893	BUICK - CHEVROLET	KELSEY-HAYES	X	A-B 147,6 B-C 189,7	A-B 67,4 C-D 65,5	A-B 15,4 C-D 12,8	1A-1B 1C-1D		
------	-------------------	--------------	---	------------------------	----------------------	----------------------	----------------	--	--



									
0894	SUZUKI	AKEBONO	X	106,4	50,2	15,6	4		

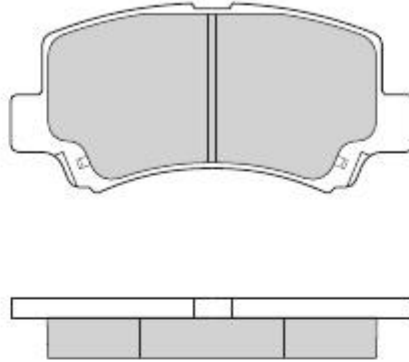



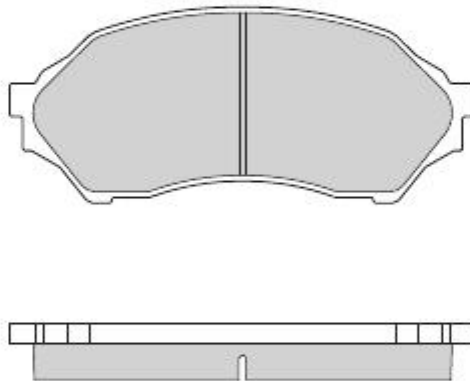



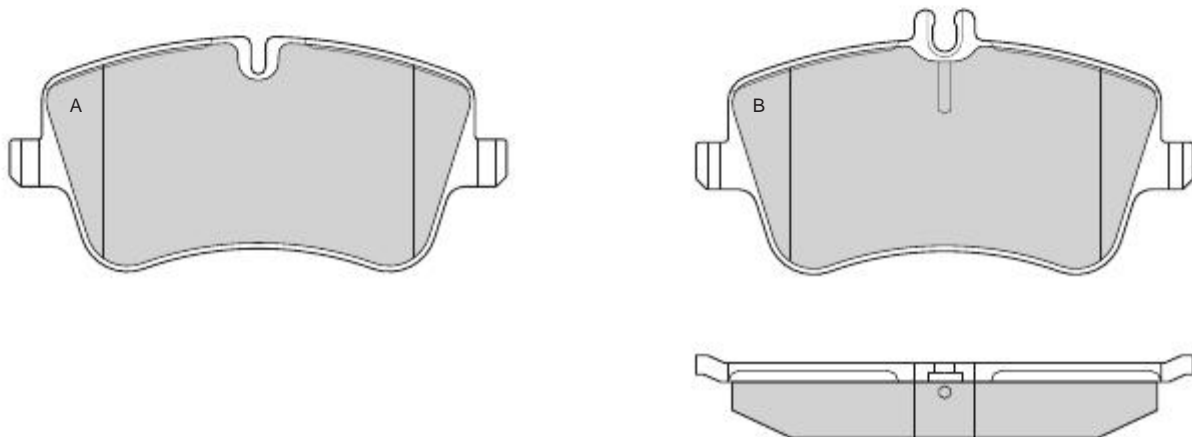



0895	MAZDA	SUMITOMO	X	123	51,8	15,2	4		
-------------	-------	----------	---	-----	------	------	---	--	--



0896	MERCEDES	LUCAS	X	131	A 62,05 B 69,75	19,85	2A-2B		
-------------	----------	-------	---	-----	--------------------	-------	-------	--	--



									
0897	MERCEDES	KELSEY-HAYES	X	A187,75 B-C-D 187,8	A-B 77,15		1C-1D	1	185

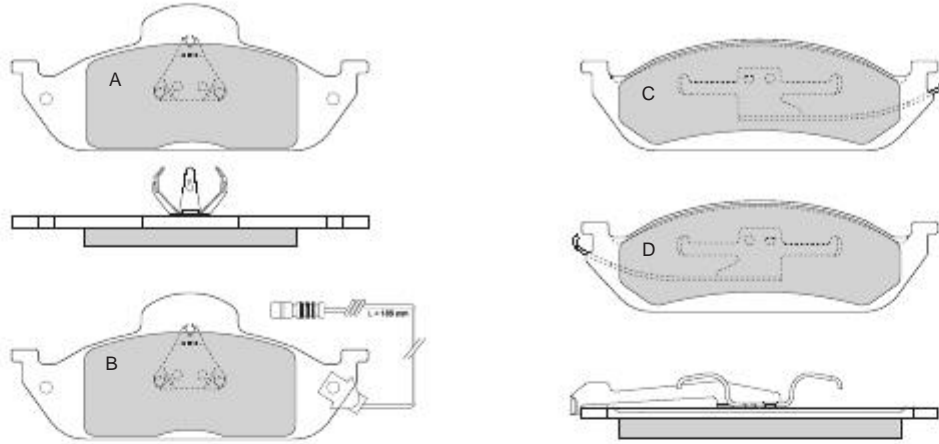





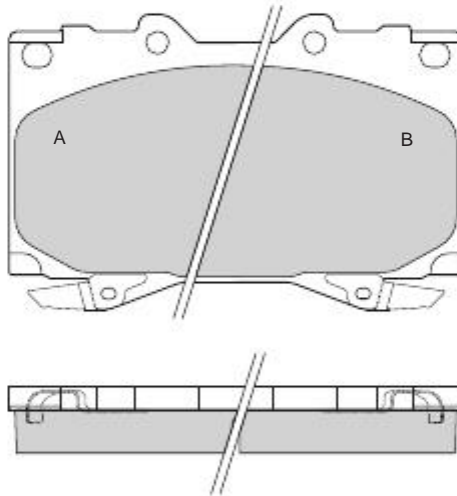



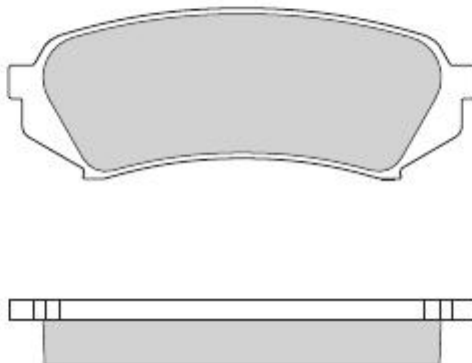

25%

0898	TOYOTA	SUMITOMO	X	119,6	78	17,5	2A-2B		
------	--------	----------	---	-------	----	------	-------	--	--



0899	TOYOTA	SUMITOMO	X	123,1	45,1	17,5	4		
------	--------	----------	---	-------	------	------	---	--	--

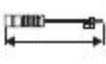

									
0900	VOLKSWAGEN	ATE	X	156,4	78,7	19,6	2A-2B	2	280

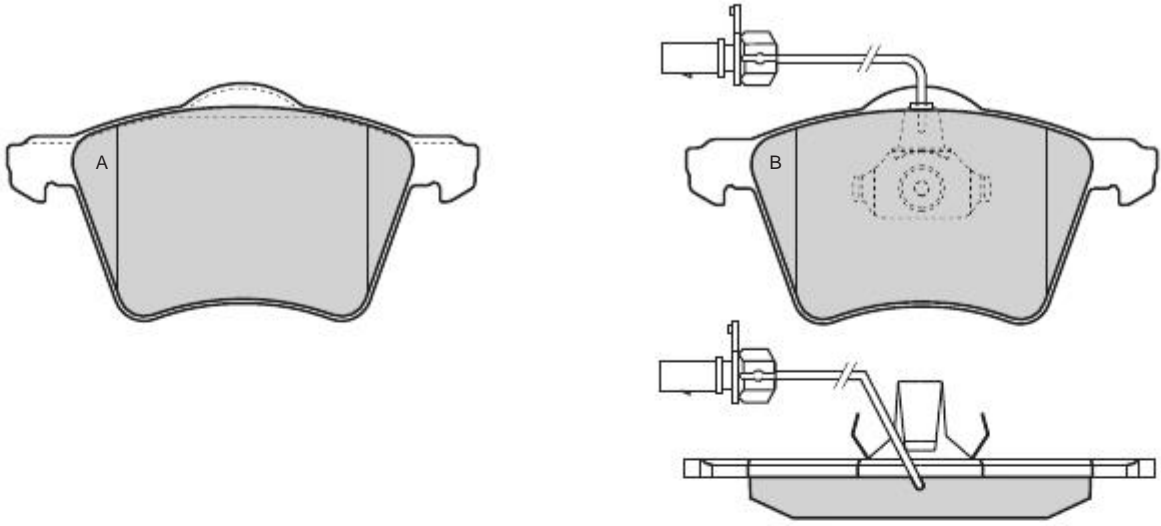



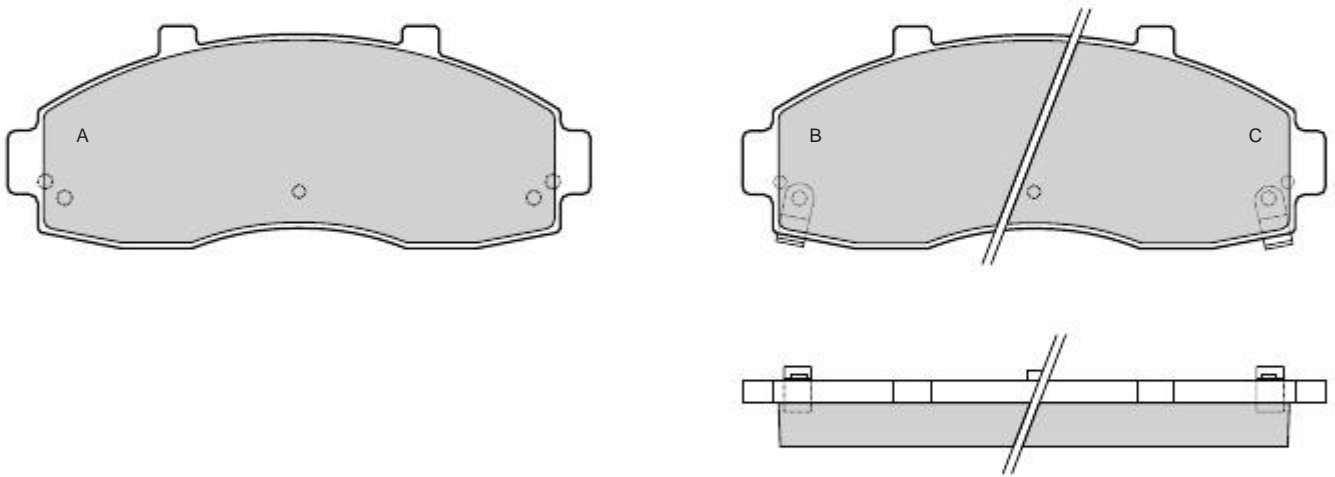



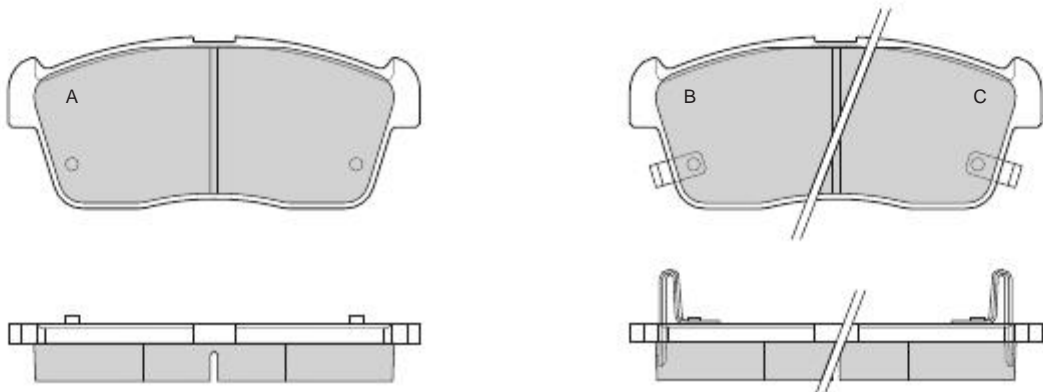

0901	KIA	WAGNER	X	154	58,7	17,5	2A 1B-1C		
------	-----	--------	---	-----	------	------	-------------	--	--



0902	DAIHATSU - SUZUKI	SUMITOMO	X	108,7	45,5	15	2A 1B-1C		
------	-------------------	----------	---	-------	------	----	-------------	--	--

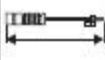

									
0903	MAZDA	AKEBONO	X	142,8	55	16,6	4		

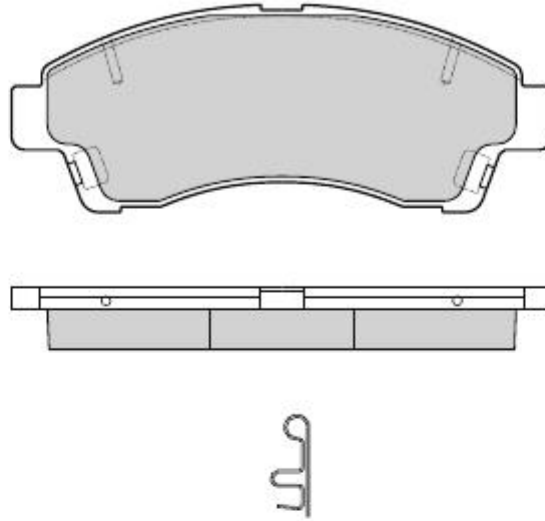



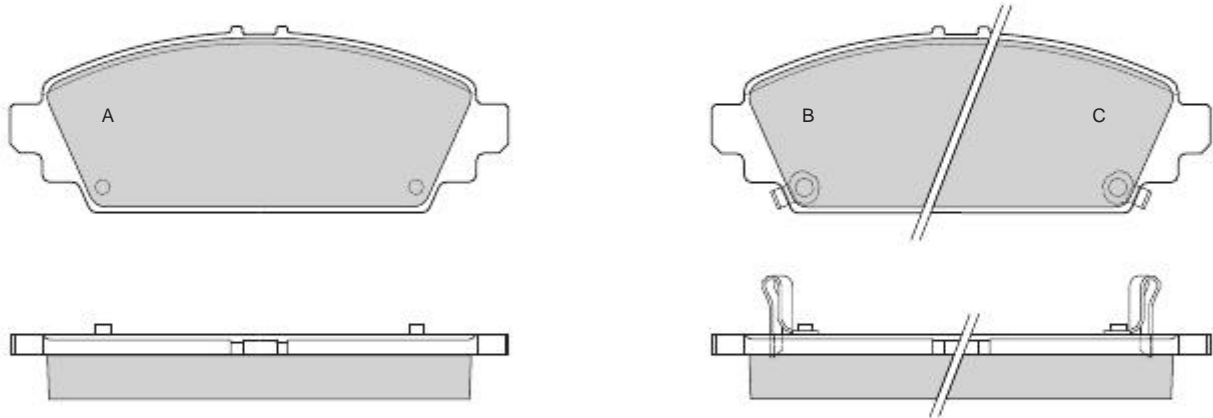



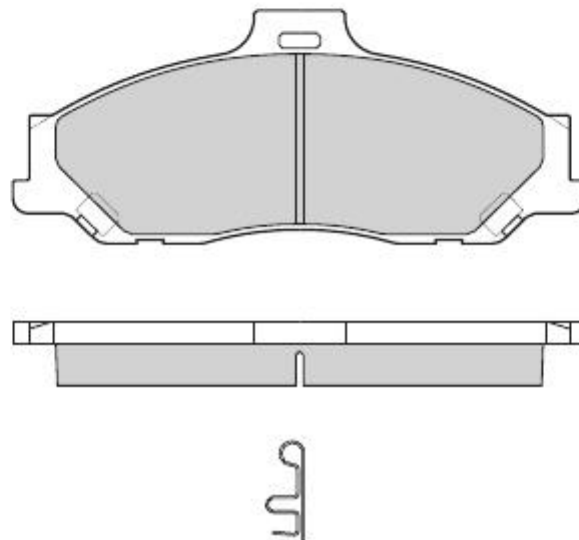

0904	HONDA	SUMITOMO	X	131,7	49,2	17,2	2A 1B-1C		
-------------	-------	----------	---	-------	------	------	-------------	--	--



0905	FORD - MAZDA	KELSEY-HAYES	X	151,5	61,7	17	4		
-------------	--------------	--------------	---	-------	------	----	---	--	--

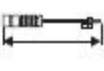

									
0906	AUDI	LUCAS	X	87	52,9	17	4		

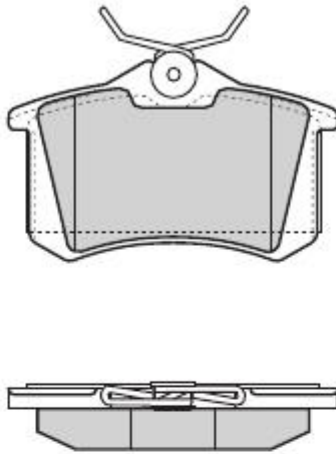



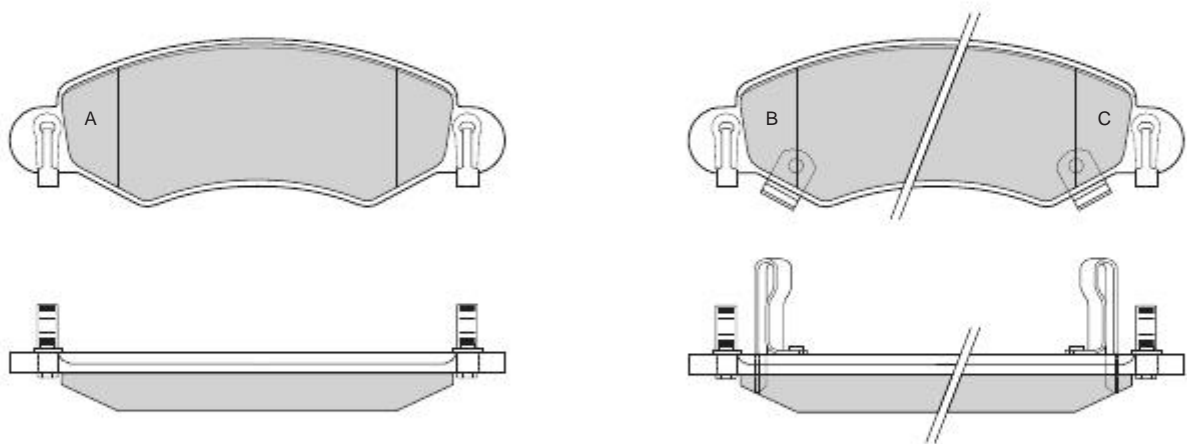



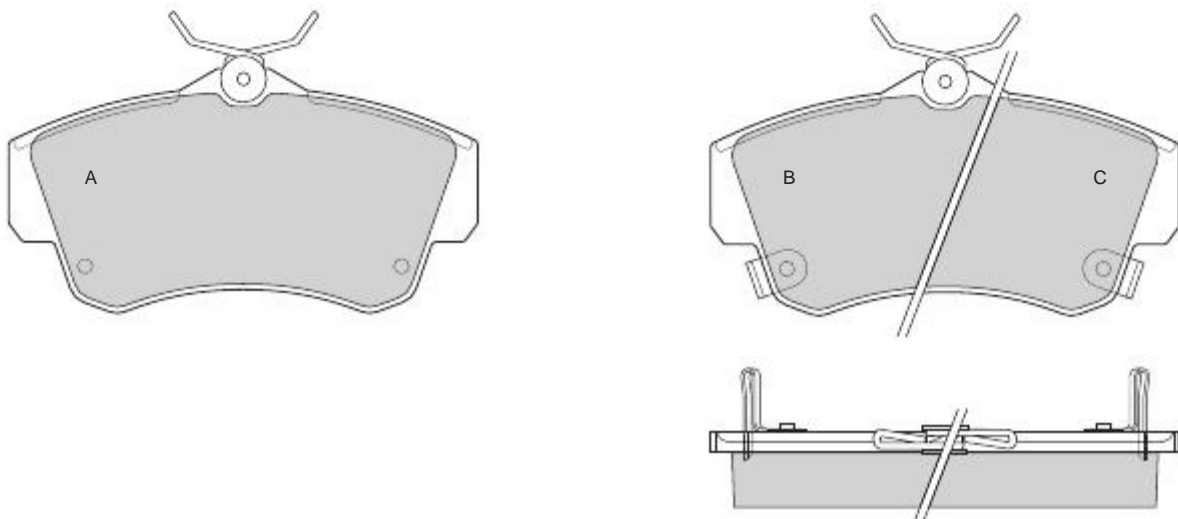

0907	OPEL - VAUXHALL	BOSCH	X	130,8	44,5	15,5	2A 1B-1C		
-------------	-----------------	-------	---	-------	------	------	-------------	--	--



0908	CHRYSLER	LUCAS	X	123,9	64,6	20	2A 1B-1C		
-------------	----------	-------	---	-------	------	----	-------------	--	--

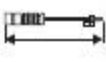

									
0909	HYUNDAI	MANDO	X	148,92	58,1	17	2A 1B-1C		

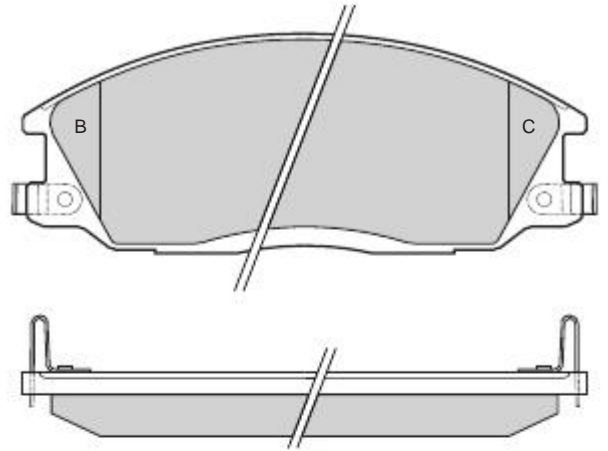
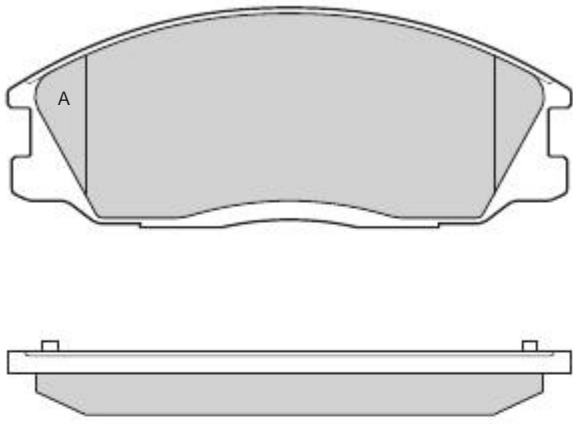



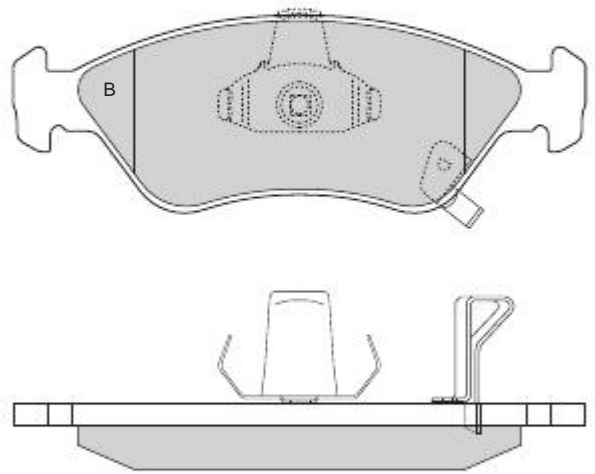
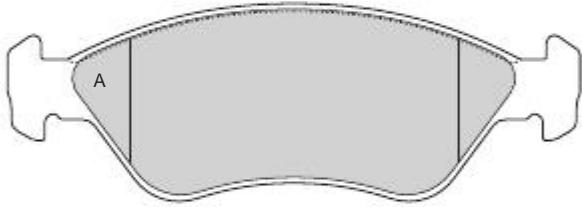



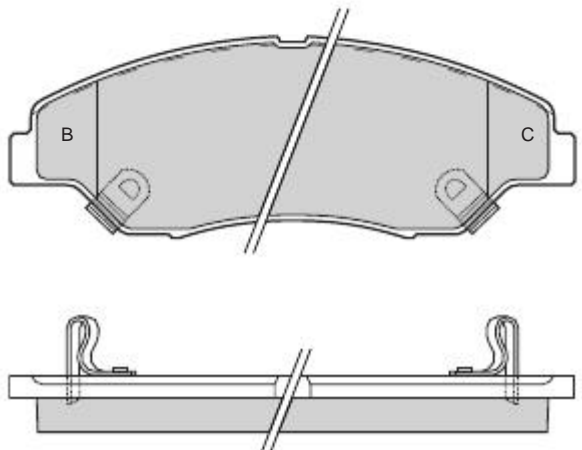
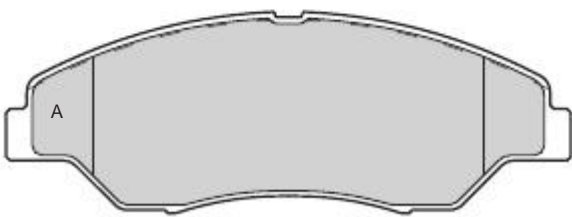



0910	KIA	ATE	X	151,3	52,5	17,8	2A-2B		
------	-----	-----	---	-------	------	------	-------	--	--



0911	KIA	SUMITOMO	X	149,2	52,9	15,1	2A 1B-1C		
------	-----	----------	---	-------	------	------	-------------	--	--



									
0912	MAZDA	SUMITOMO	X	131,4	56,1	16	2A 1B-1C		

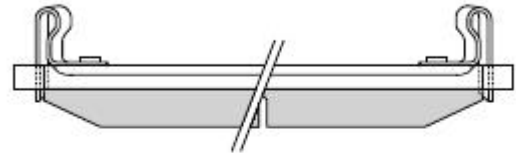
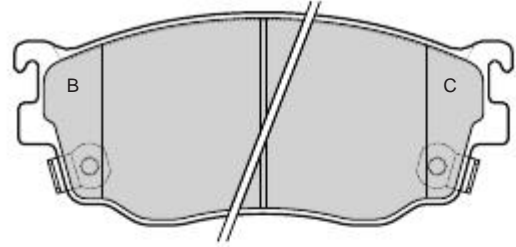
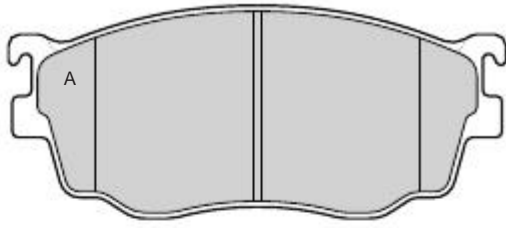



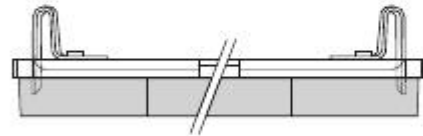
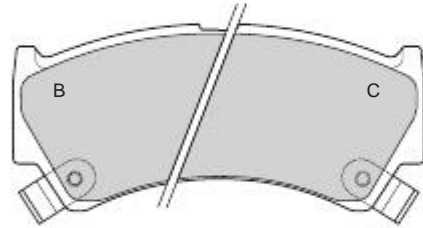



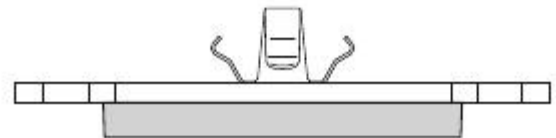
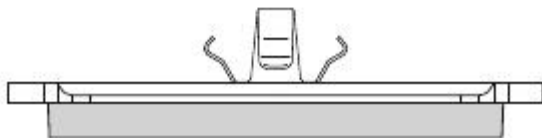
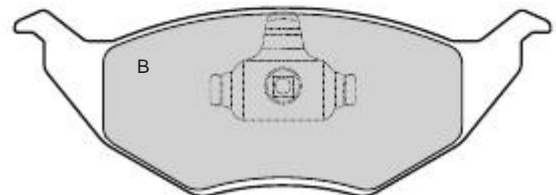
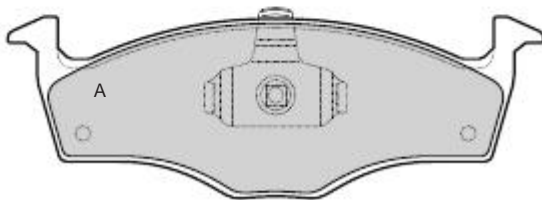

0913	SUZUKI	SUMITOMO	X	108,5	49,5	15	2A 1B-1C		
-------------	--------	----------	---	-------	------	----	-------------	--	--

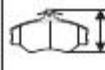

0914	SEAT - VOLKSWAGEN	KELSEY-HAYES	X	141,5	A 47,5 B 49,7	14,3	2A-2B		
-------------	-------------------	--------------	---	-------	------------------	------	-------	--	--

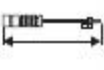

									
0915	OPEL	LUCAS	X	131,4	A 55,6 B 51,5	17	2A-2B		

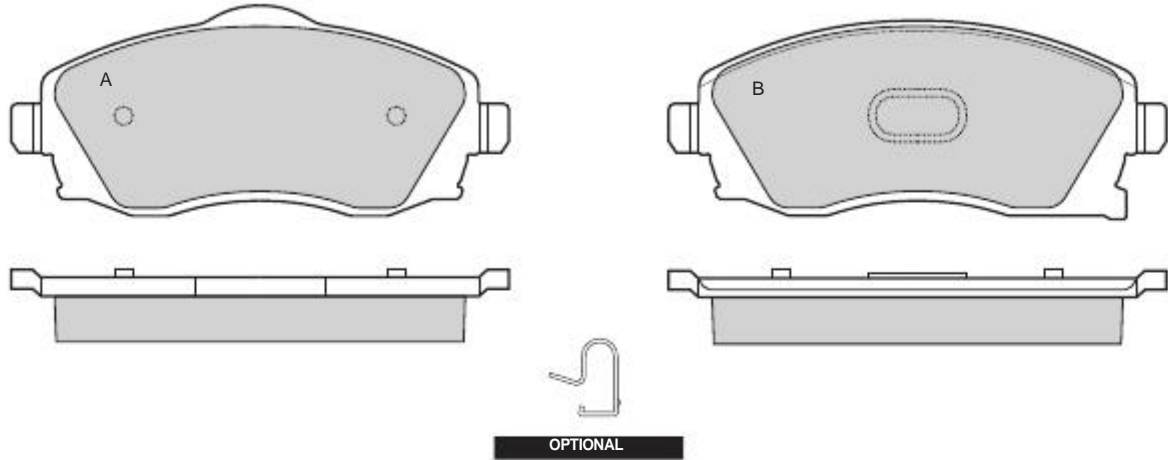



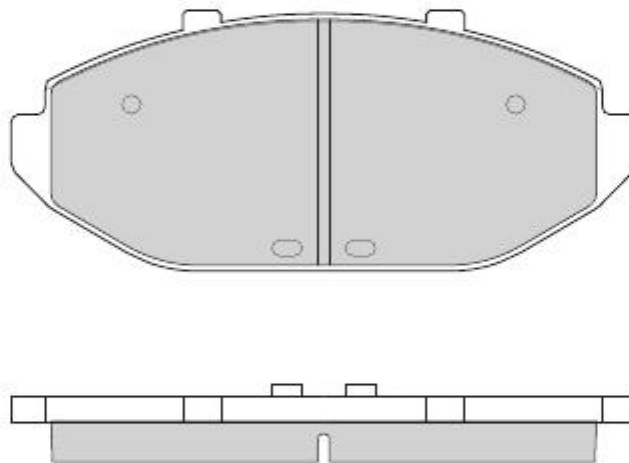



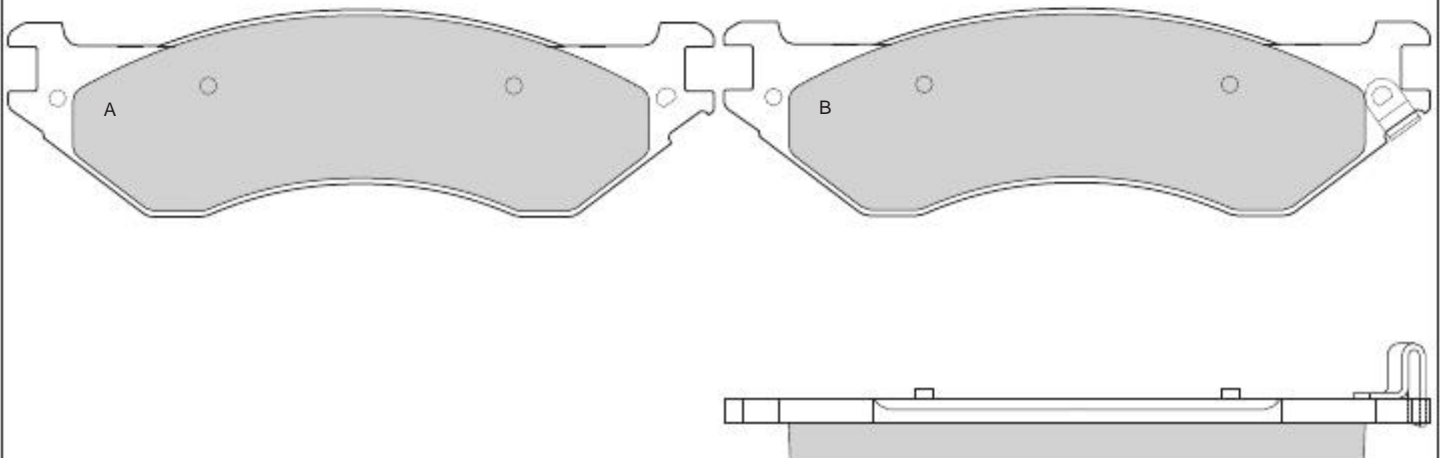

0916	FORD USA - LINCOLN MERCURY	BENDIX	X	165,1	68,8	17,2	4		
------	-------------------------------	--------	---	-------	------	------	---	--	--



0917	FORD TRUCK - LINCOLN DODGE TRUCK	KELSEY-HAYES	X	X	188,4	56,5	16,5	2A-2B	
------	-------------------------------------	--------------	---	---	-------	------	------	-------	--

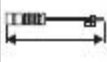

									
0918	CHEVROLET TRUCK						1B-1C		

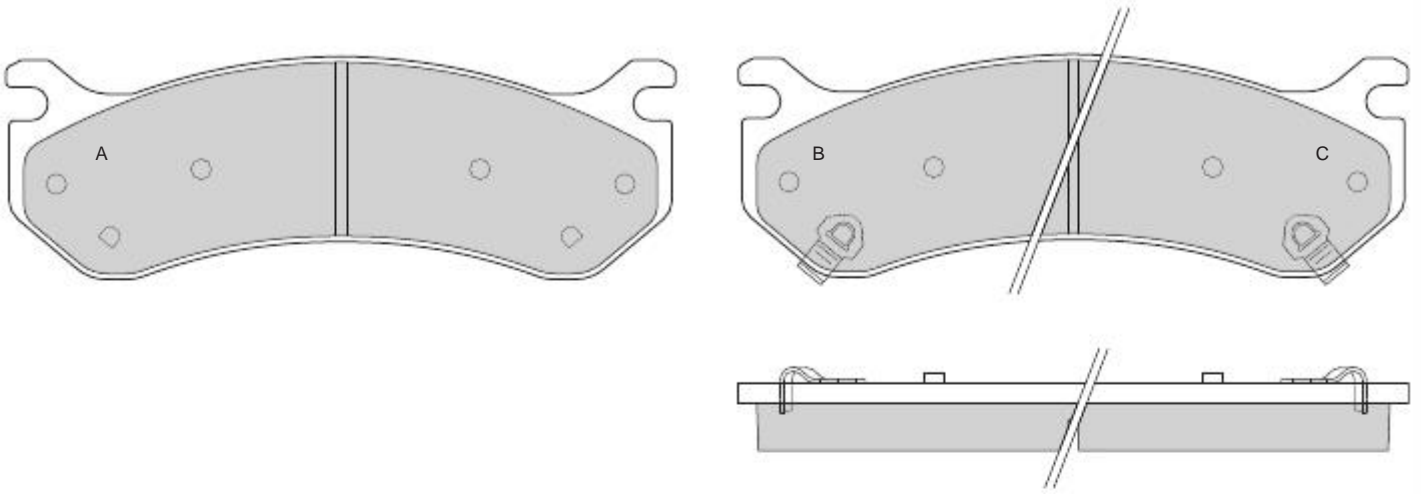



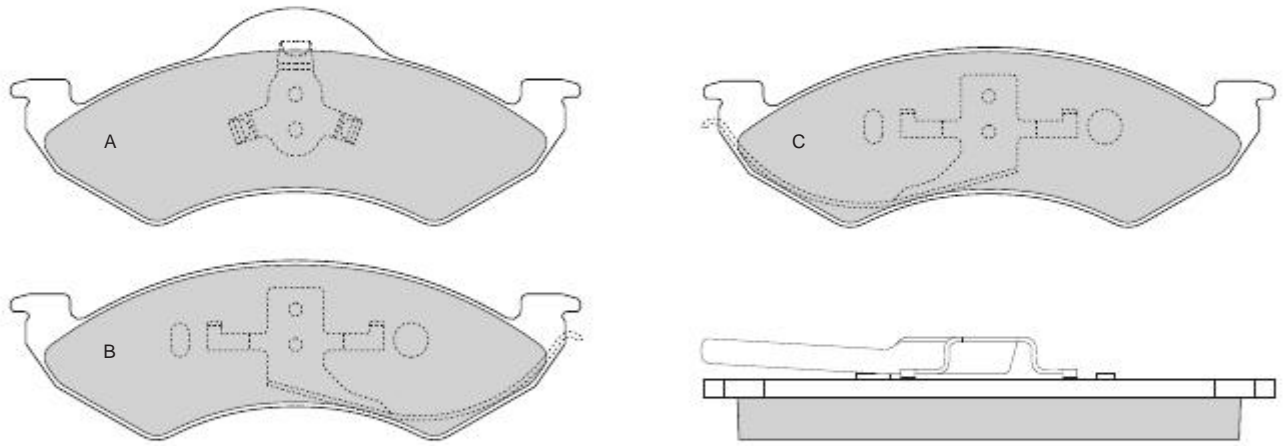



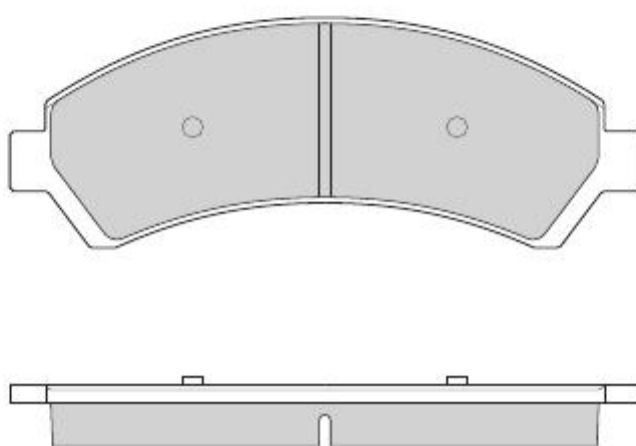

0919	DODGE TRUCK		X	191,7	A 72,8 B-C 60,1	20,2	2A 1B-1C		
-------------	--------------------	--	---	-------	--------------------	------	-------------	--	--



0920	CHEVROLET TRUCK GMC TRUCK - OLDSMOBILE		X	166,3	60,8	16,3	4		
-------------	---	--	---	-------	------	------	---	--	--

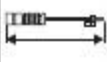

									
0921	CITROEN	GIRLING	X	130	57	19	4		

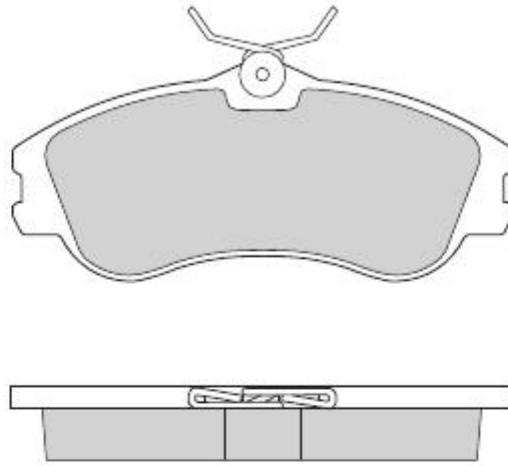



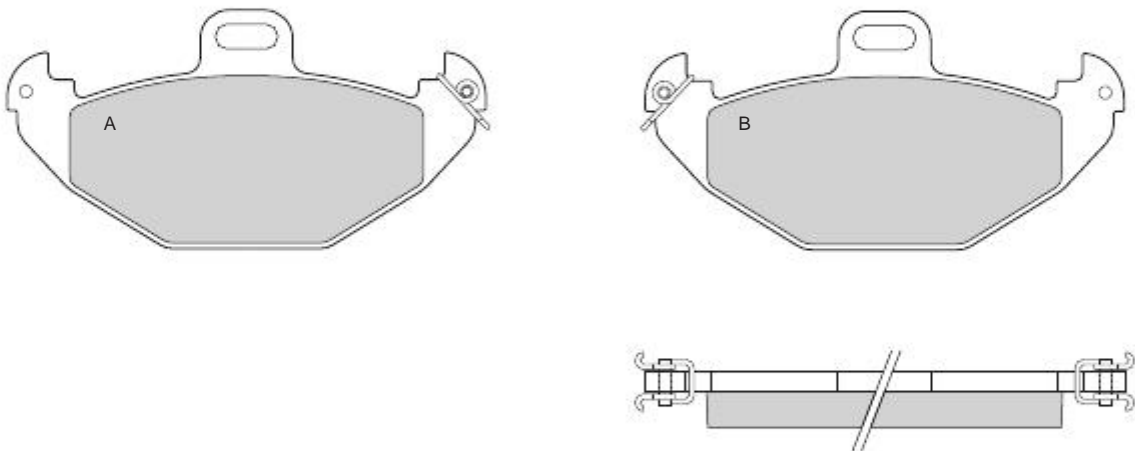



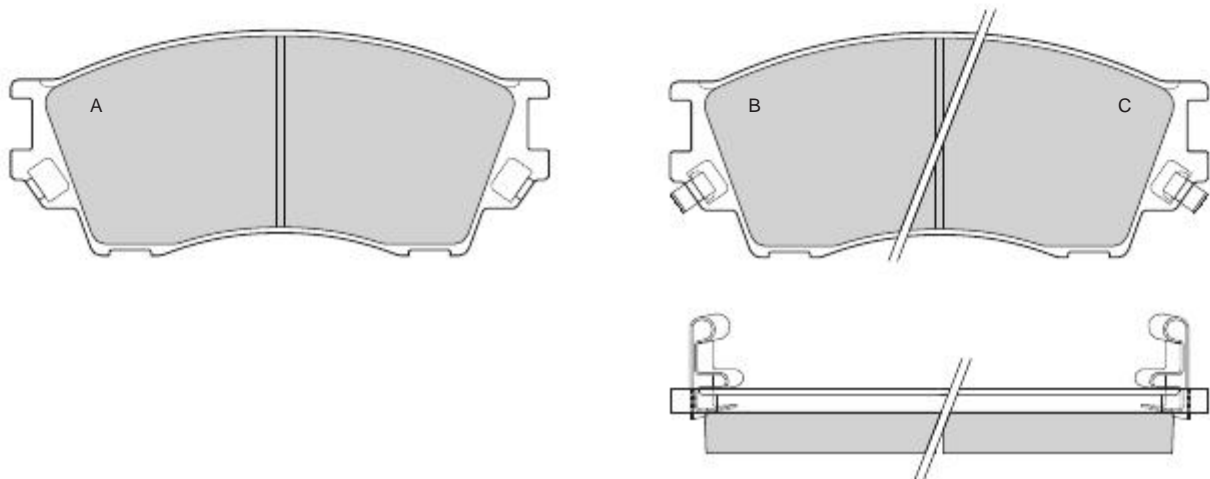

0922	RENAULT	BREMBO	X	126	63	14,5	2A-2B		
------	---------	--------	---	-----	----	------	-------	--	--



0923	MAZDA	AKEBONO	X	142	59,5	16,8	2A 1B-1C		
------	-------	---------	---	-----	------	------	-------------	--	--

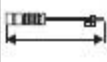

									
0924	PEUGEOT	BREMBO	X	131,8	77,3	15,8	2A-2B	4	305

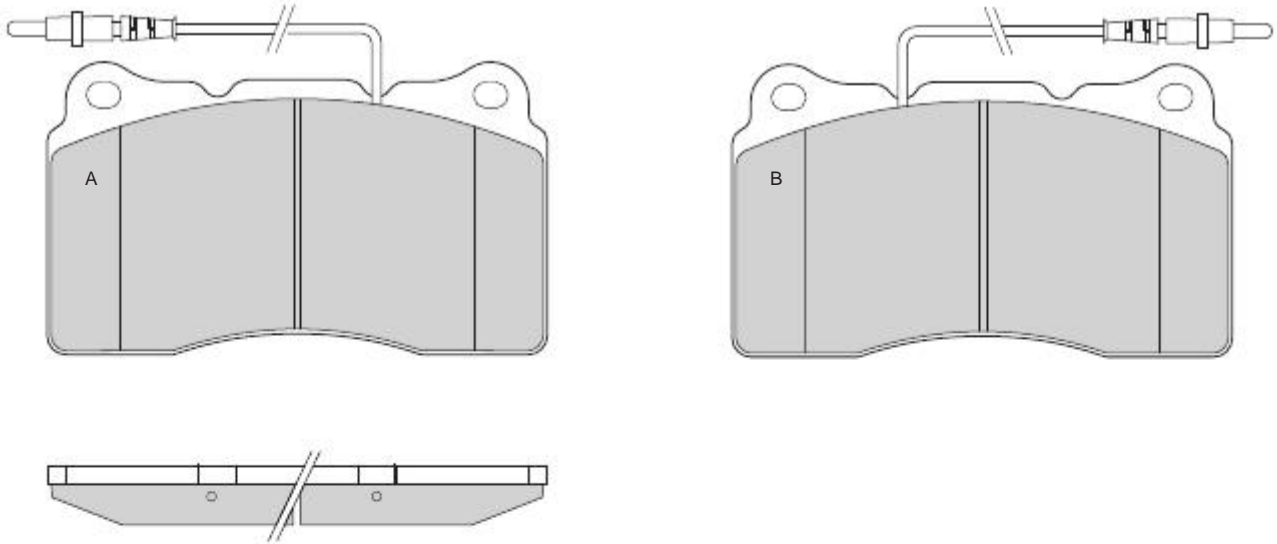



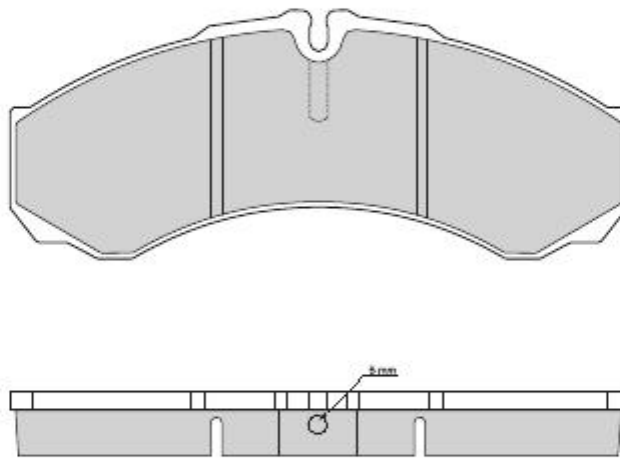



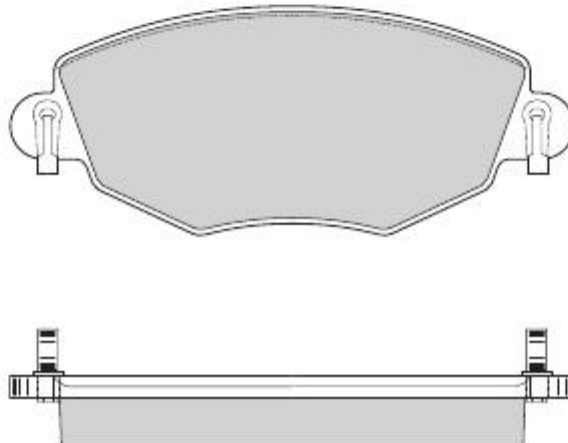

0925	FIAT IVECO	BREMBO	X	164,8	66,5	17	4		
-------------	------------	--------	---	-------	------	----	---	--	--



0926	FORD - JAGUAR	BOSCH	X	148,8	60,3	18,5	4		
-------------	---------------	-------	---	-------	------	------	---	--	--

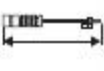

									
0927	FORD - JAGUAR	BOSCH	X	115,6	51,8	16,2	4		

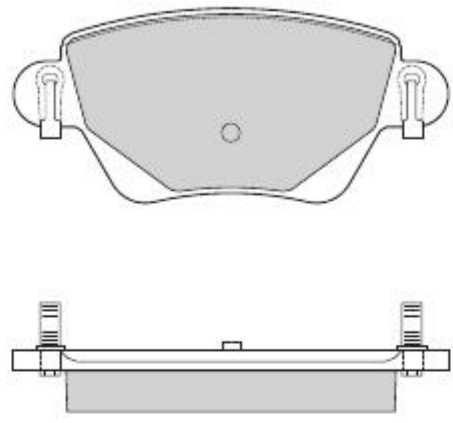



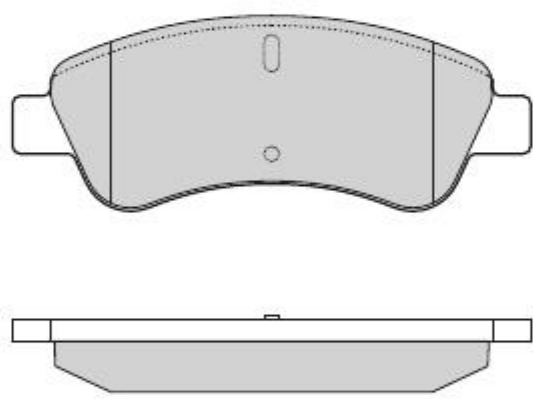



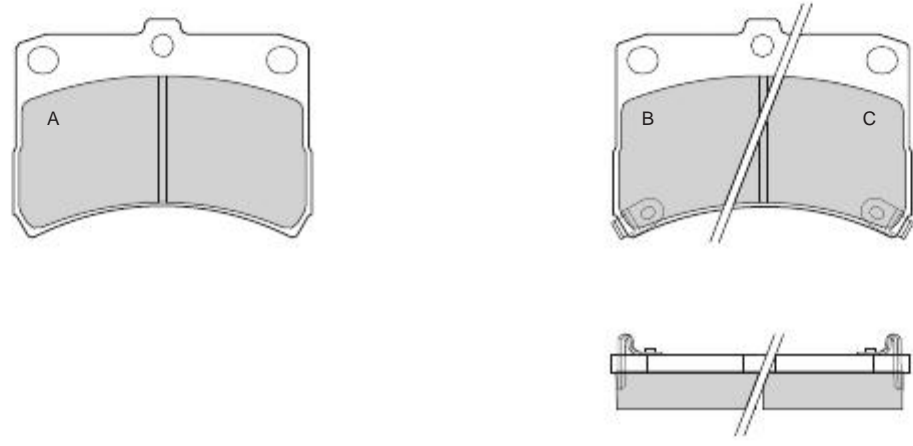

0928	CITROEN - PEUGEOT	BOSCH	X	136,8	51,6	19	4		
------	-------------------	-------	---	-------	------	----	---	--	--



0929	DAIHATSU	SUMITOMO	X	78,8	58,2	14,4	2A 1B-1C		
------	----------	----------	---	------	------	------	-------------	--	--

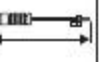

									
0930	CITROEN - PEUGEOT	BOSCH	X	168,9	61,2	17,8	2A-2B	2	180 410

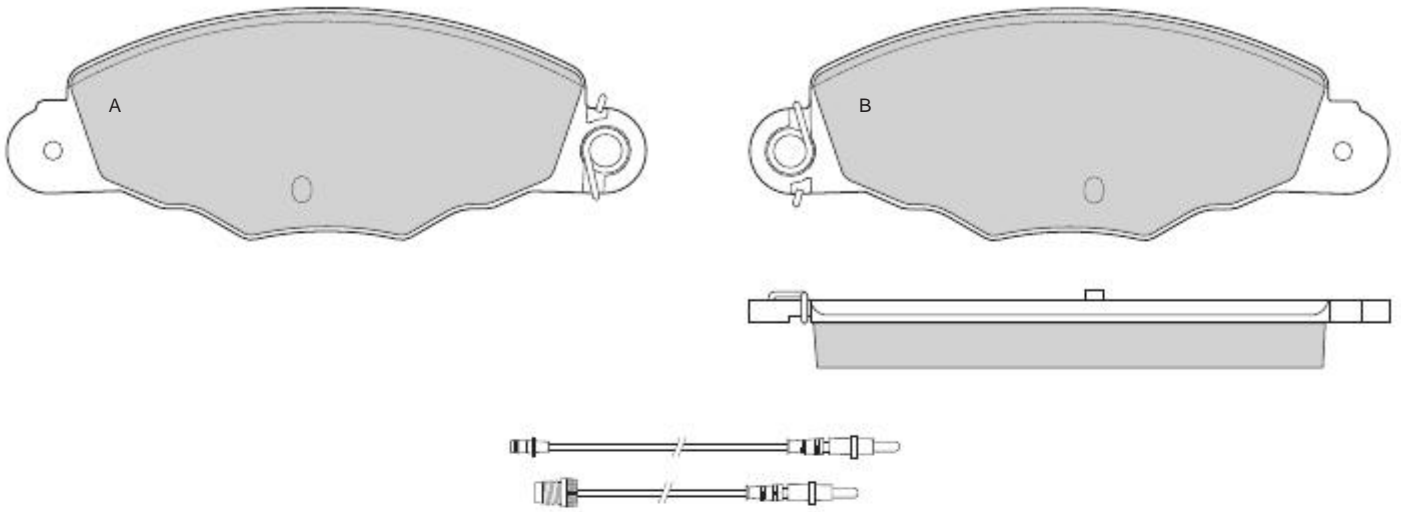



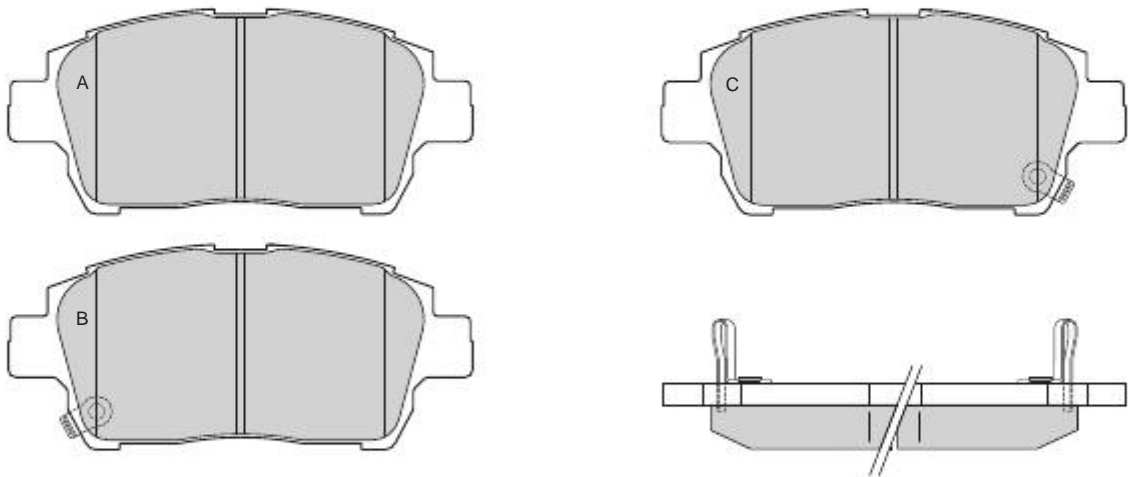



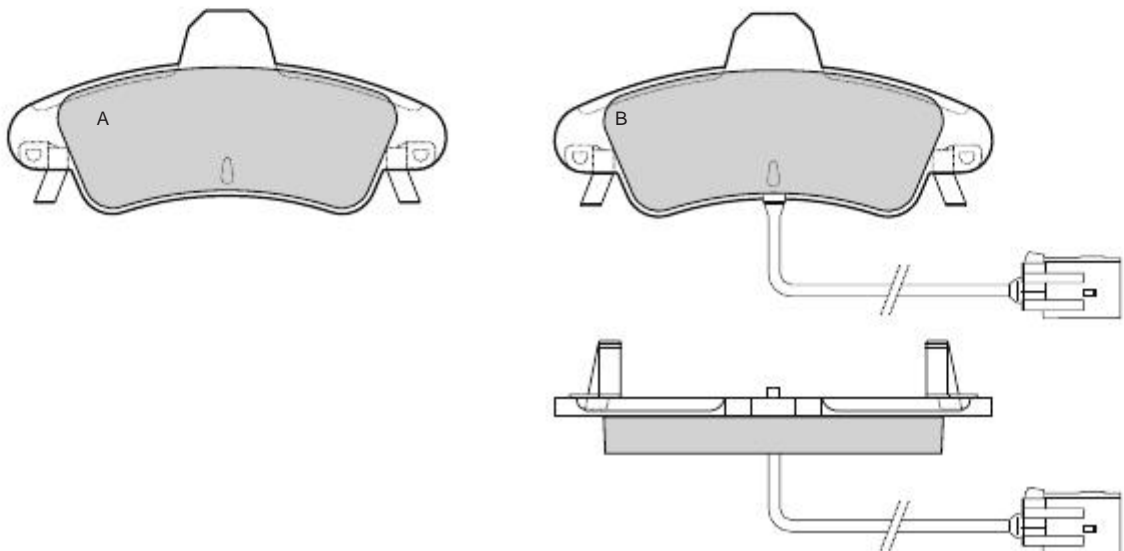

0931	TOYOTA	AKEBONO	X	116,3	51,6	16,5	2A 1B-1C		
------	--------	---------	---	-------	------	------	-------------	--	--



0932	FORD	BENDIX	X	115,7	53,7	14,7	2A-2B	2	225
------	------	--------	---	-------	------	------	-------	---	-----

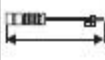

									
0933	JAGUAR	TRW	X	163,2	58	17,8	4		

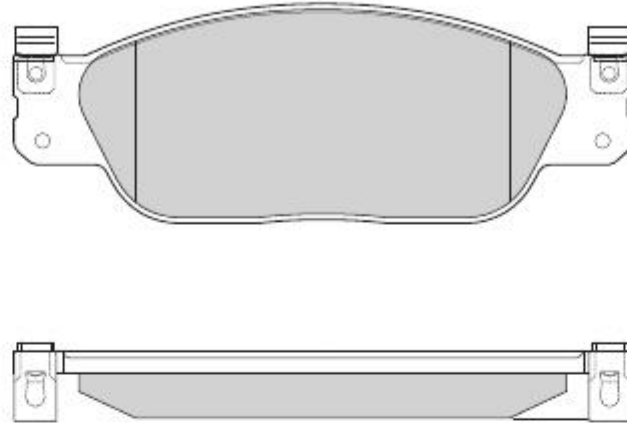



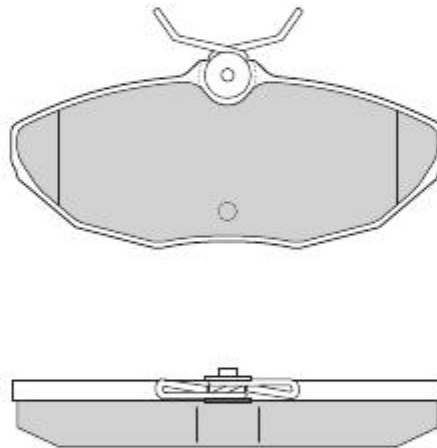



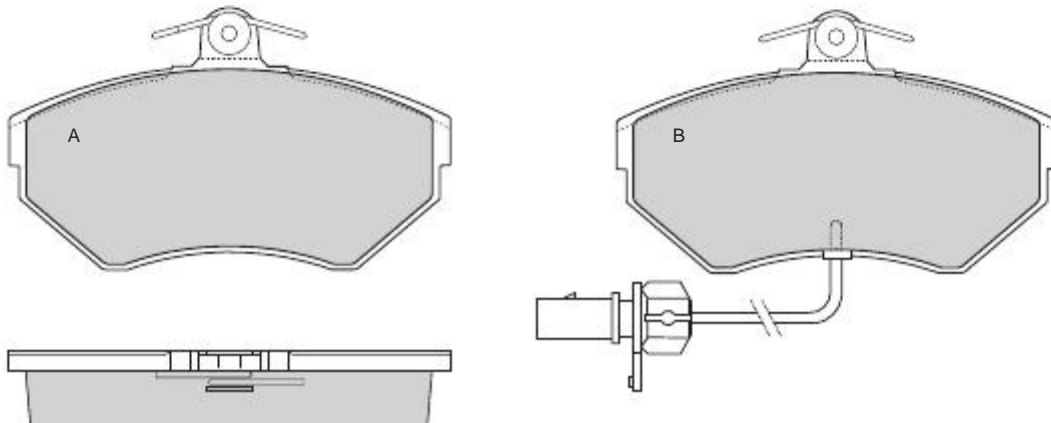

0934	JAGUAR - LINCOLN	TRW	X	114,3	49,5	17,8	4		
-------------	------------------	-----	---	-------	------	------	---	--	--



0935	AUDI - VOLKSWAGEN	GIRLING	X	118,9	69,5	19,6	2A-2B	2	210
-------------	-------------------	---------	---	-------	------	------	-------	---	-----

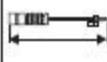

									
0936	MERCEDES	ATE	X	63,38	78,2	15,8	3A-1B		

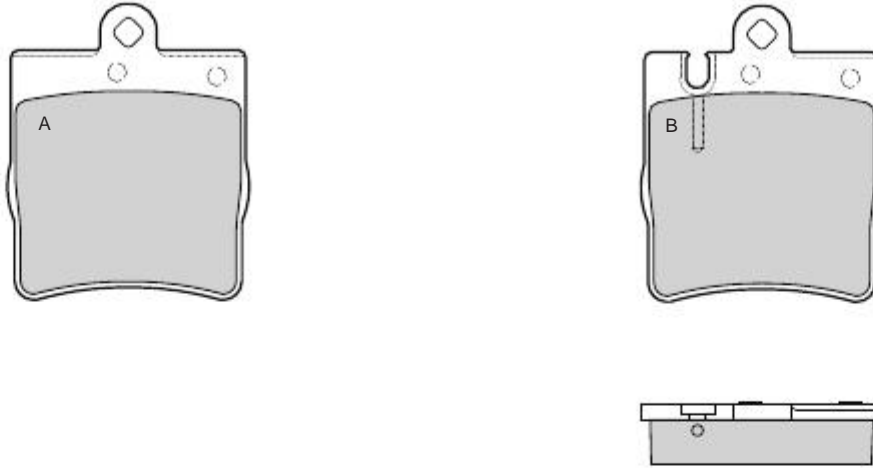



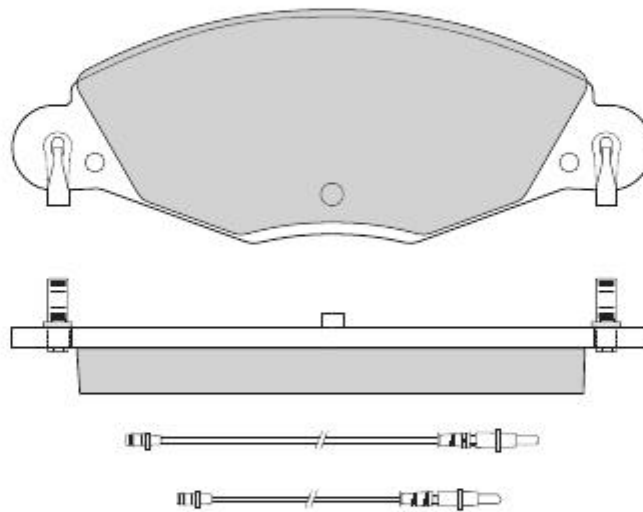





0937	CITROEN	BOSCH	X	168,8	61,3	18	4	2 2	410 280
-------------	---------	-------	---	-------	------	----	---	--------	------------



0938	CITROEN	CITROEN	X	73	70,5	15,2	4		
-------------	---------	---------	---	----	------	------	---	--	--

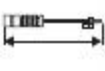

									
0939	CITROEN	BOSCH	X	148,8	59,3	17,8	4	2 2	410 280

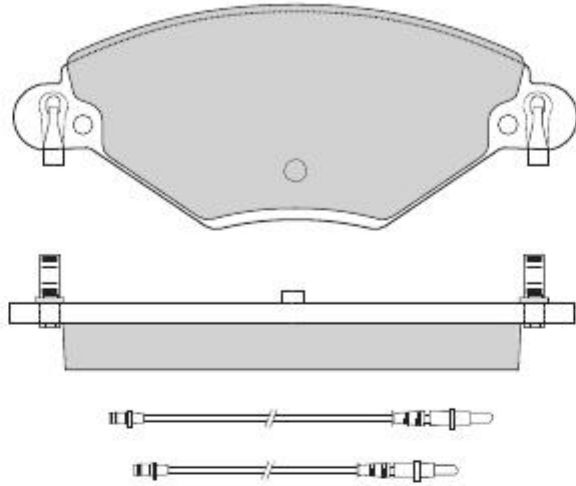



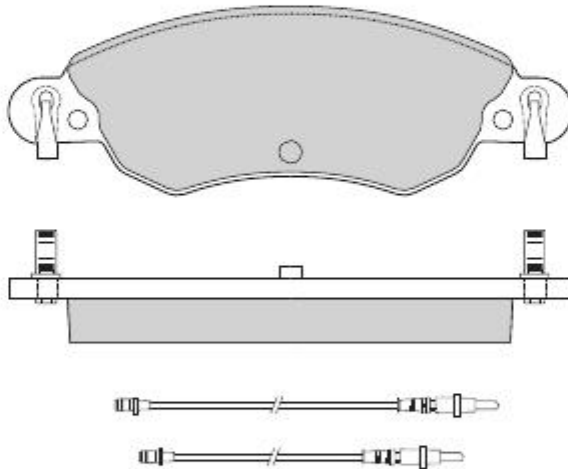



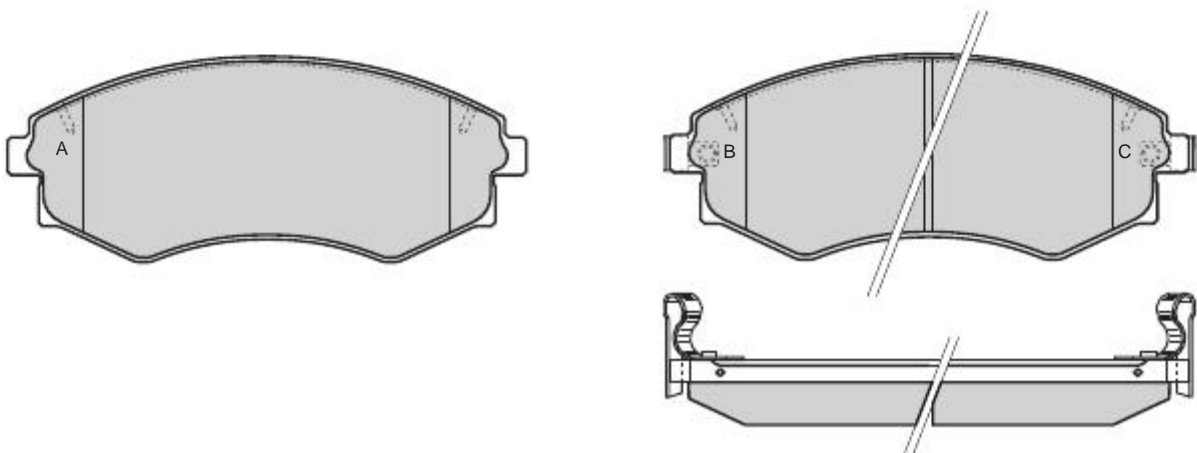



0940	CITROEN	BOSCH	X	148,9	50	17	4	2 2	410 280
-------------	---------	-------	---	-------	----	----	---	--------	------------



0941	HYUNDAI	SUMITOMO	X	137,1	54,4	17,2	2A 1B-1C		
-------------	---------	----------	---	-------	------	------	-------------	--	--



									
0942	FIAT	BOSCH	X	122,8	53,6	17,8	3A-1B	1	220

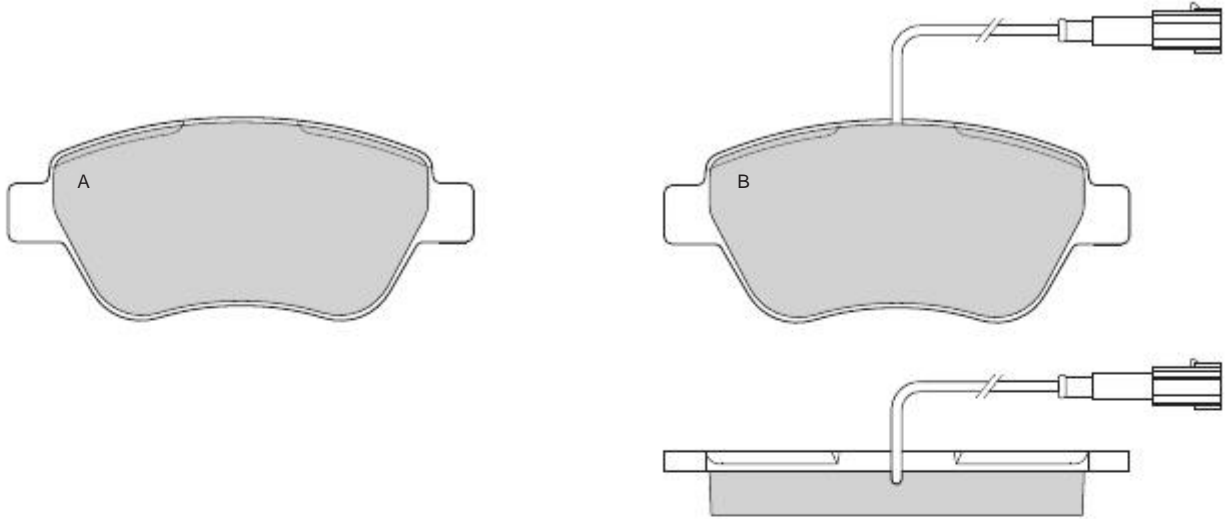



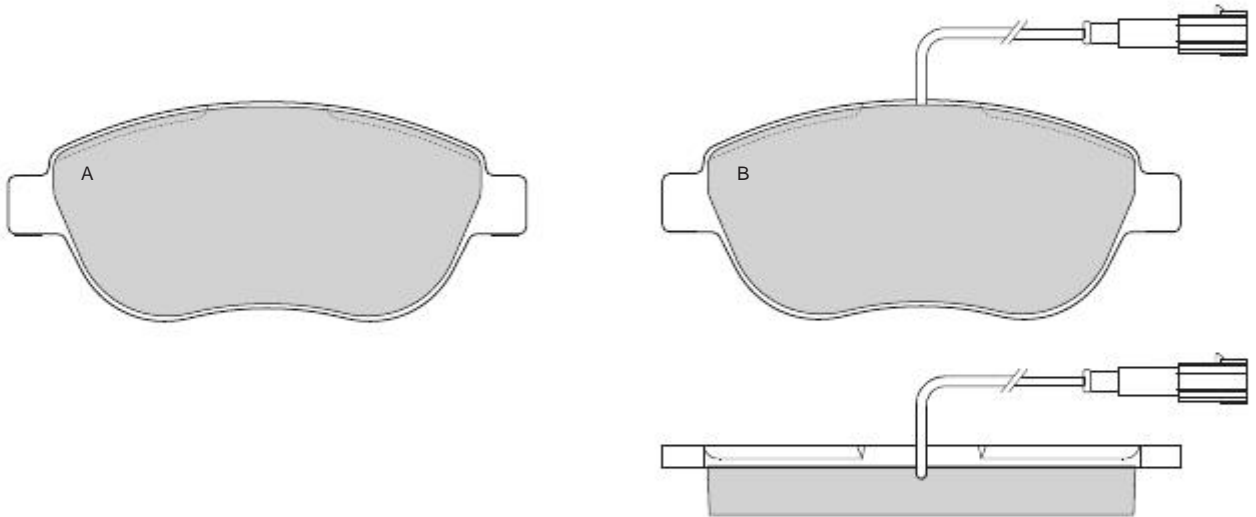



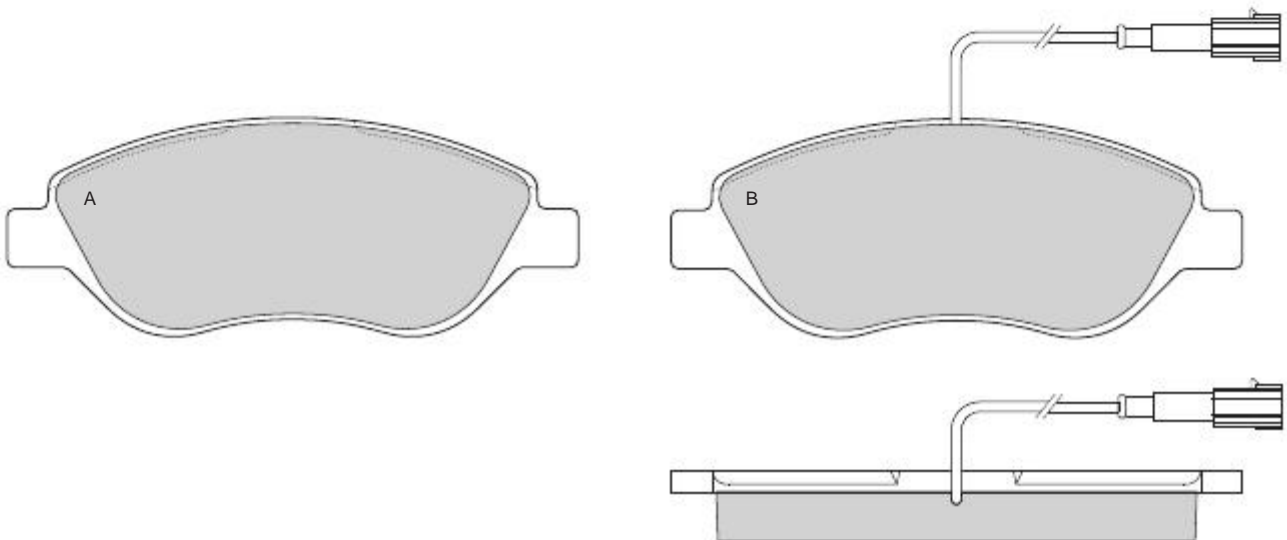

0943	FIAT	BOSCH	X	136,8	57,9	18,3	3A-1B	1	220
-------------	------	-------	---	-------	------	------	-------	---	-----



0944	FIAT	BOSCH	X	150,8	57,8	18,5	3A-1B	1	220
-------------	------	-------	---	-------	------	------	-------	---	-----

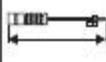

									
0945	NISSAN	GIRLING	X	131,6	58,6	17,2	4		

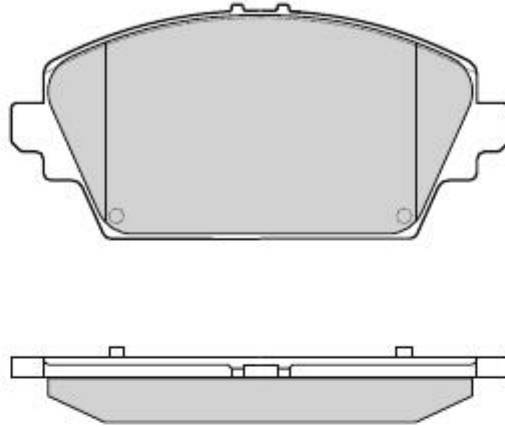



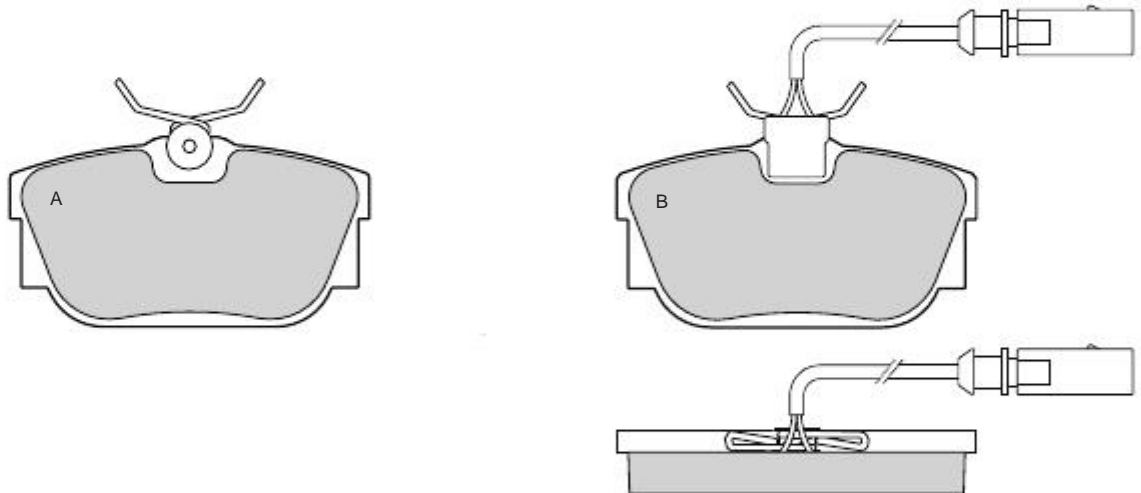



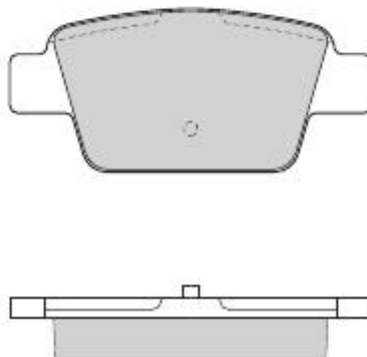

0946	FORD - SEAT VOLKSWAGEN	LUCAS	X	94,9	51	16,5	2A-2B	2	210
-------------	---------------------------	-------	---	------	----	------	-------	---	-----



0947	FIAT	BOSCH	X	94,8	42,8	16,3	4		
-------------	------	-------	---	------	------	------	---	--	--

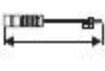

									
0948	IVECO	PERROT	X	149	69	18	2A-2B	2	280

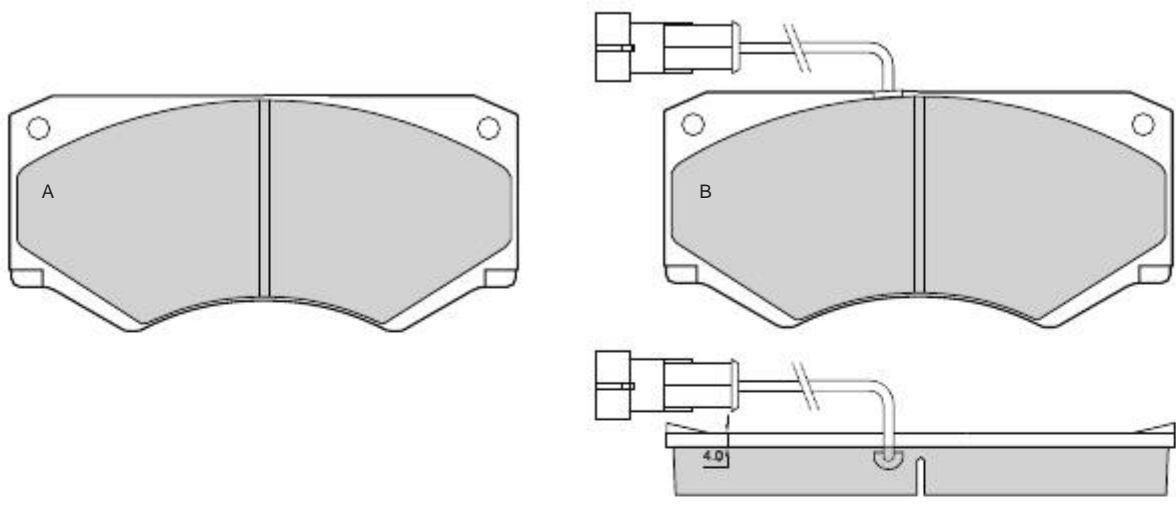



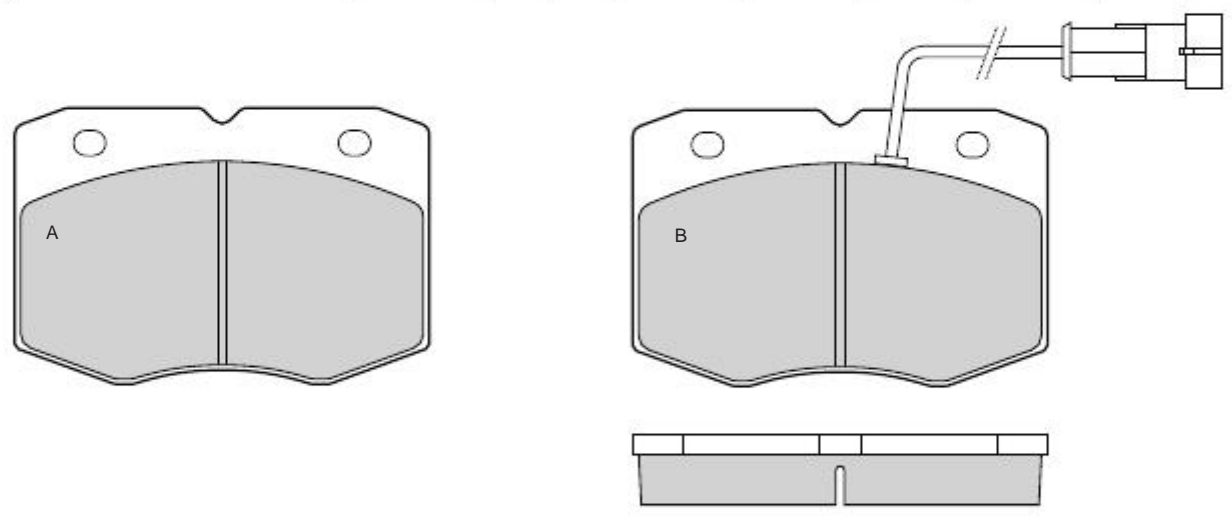



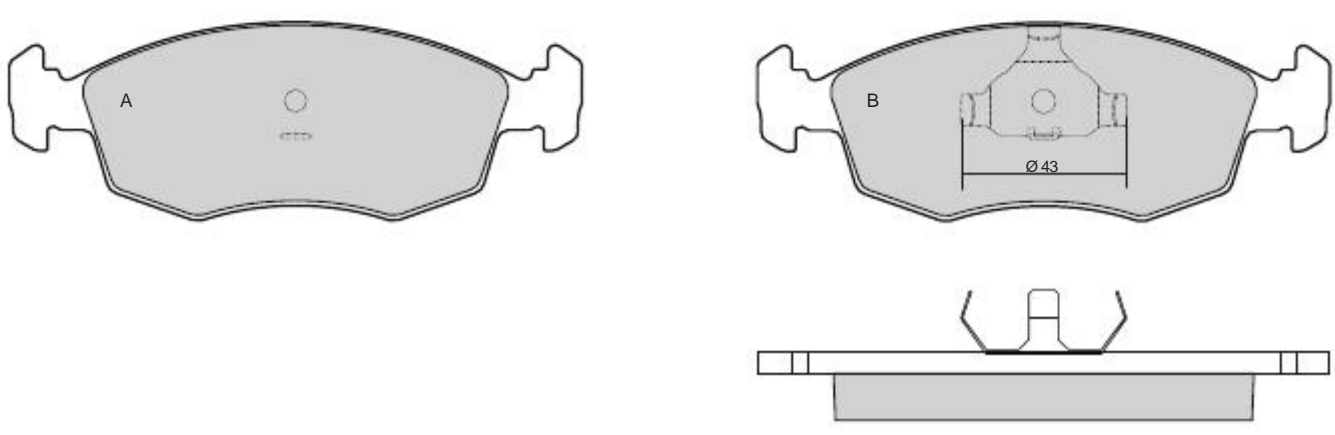



0949	IVECO	BREMBO	X	109,6	73	18,3	2A-2B	2	280
------	-------	--------	---	-------	----	------	-------	---	-----



0950	FIAT - MERCURY	ATE	X	151,3	52,5	18	2A-2B		
------	----------------	-----	---	-------	------	----	-------	--	--



									
0951	FIAT	ATE	X	A 151,3 B 150,1	52,5	18	2A-2B		

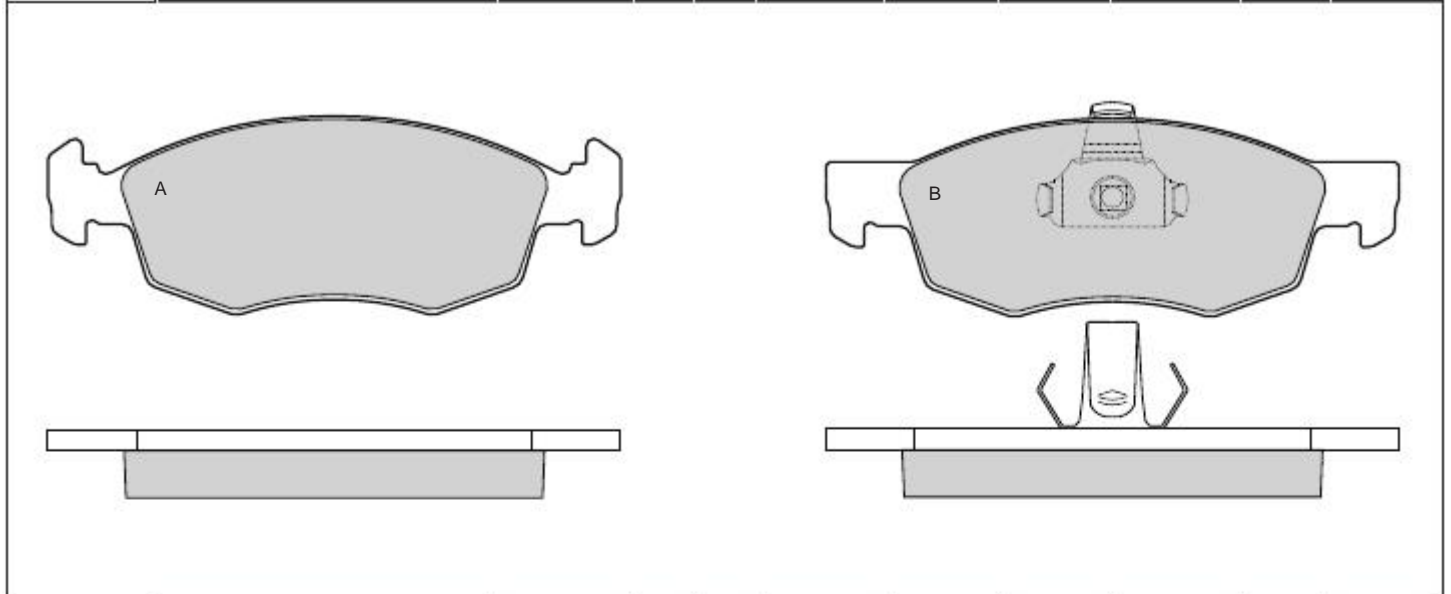



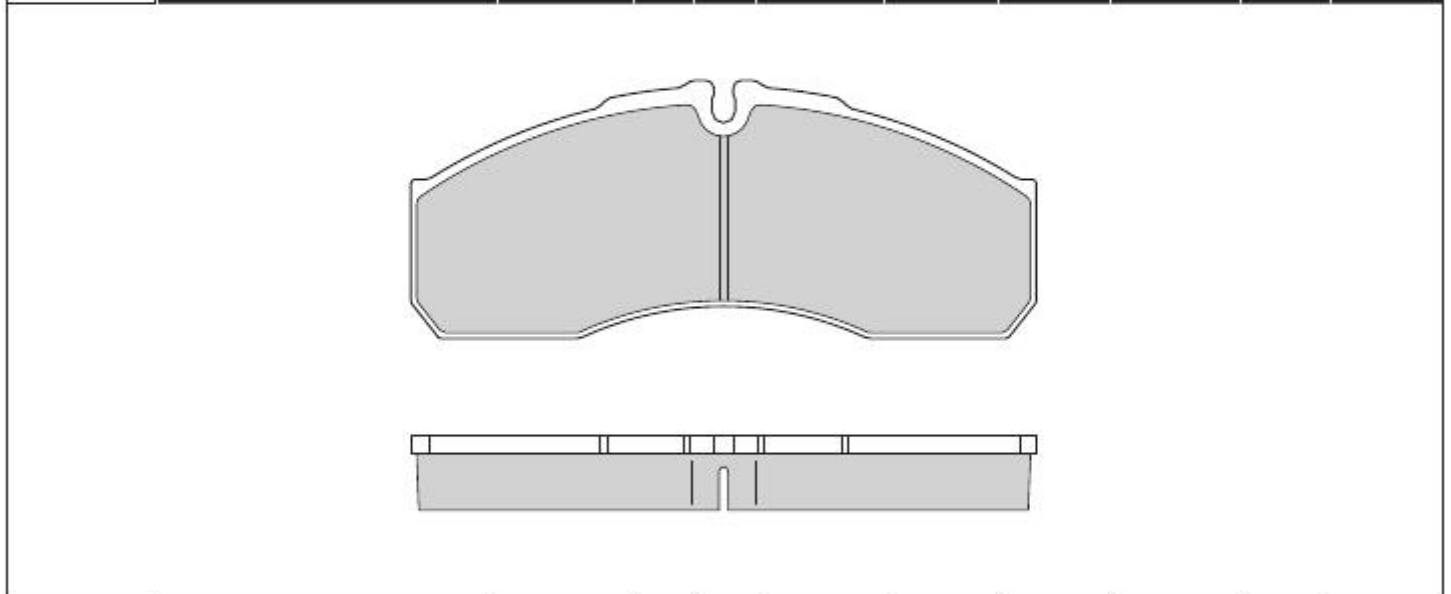



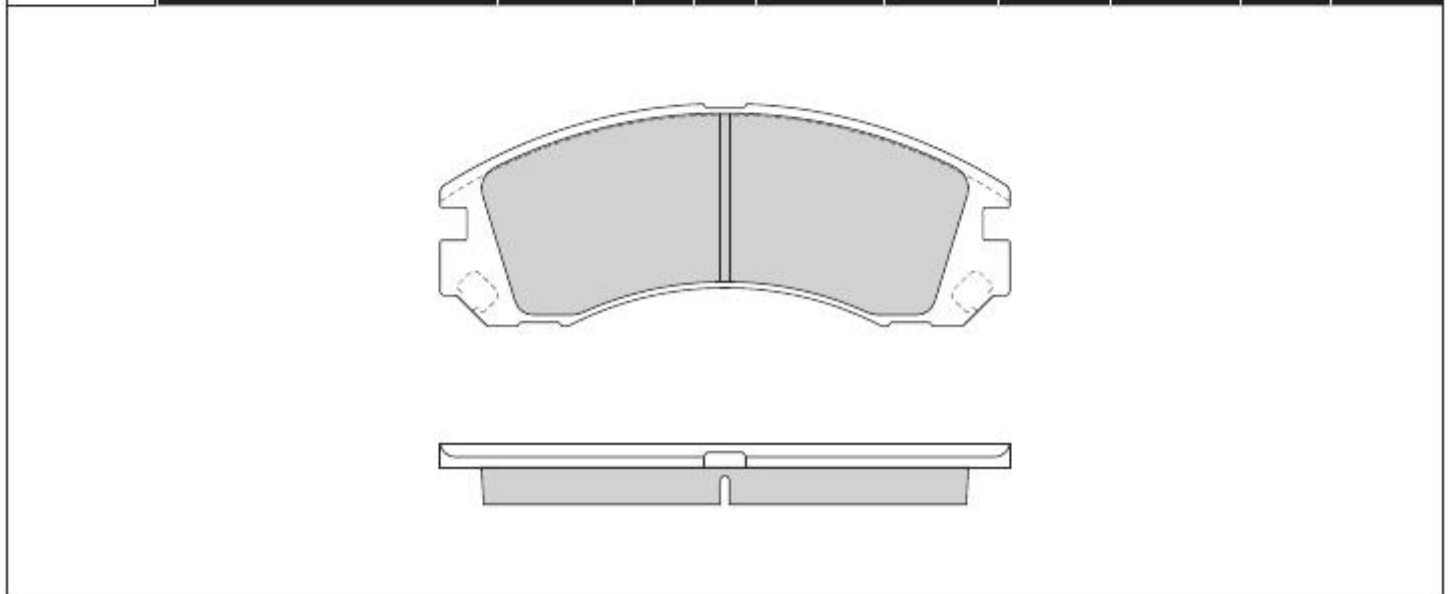



0952	IVECO - MERCEDES RENAULT	BREMBO	X	X	164,6	68	20	4	
------	-----------------------------	--------	---	---	-------	----	----	---	--



0953	MITSUBISHI	AKEBONO	X		149,8	58,5	15,8	4	
------	------------	---------	---	--	-------	------	------	---	--



									
0954	MAZDA	AKEBONO	X	107,7	39,4	13	4		

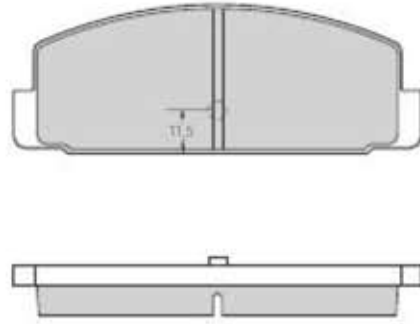



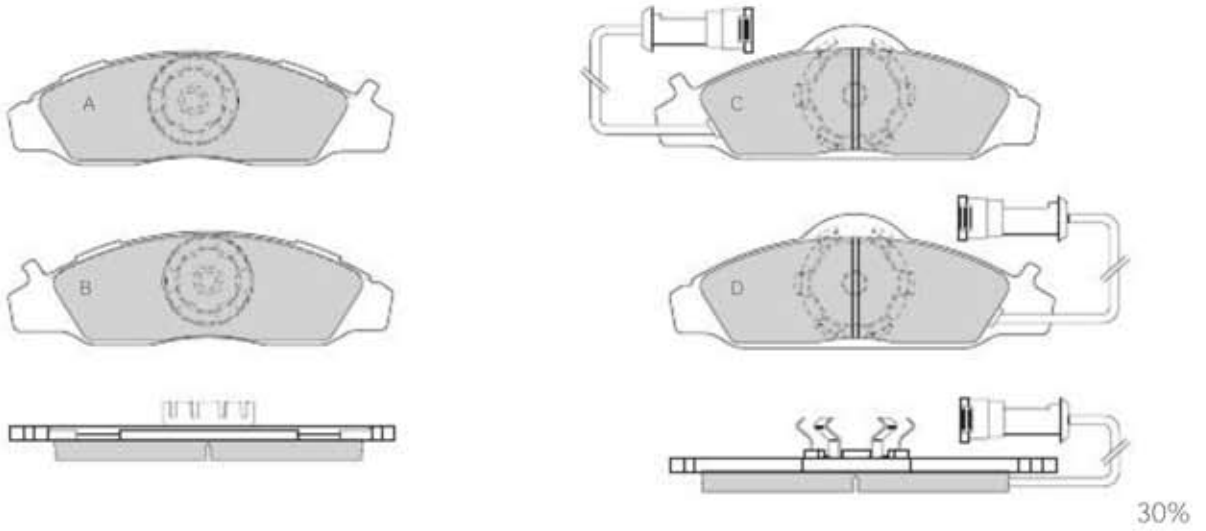



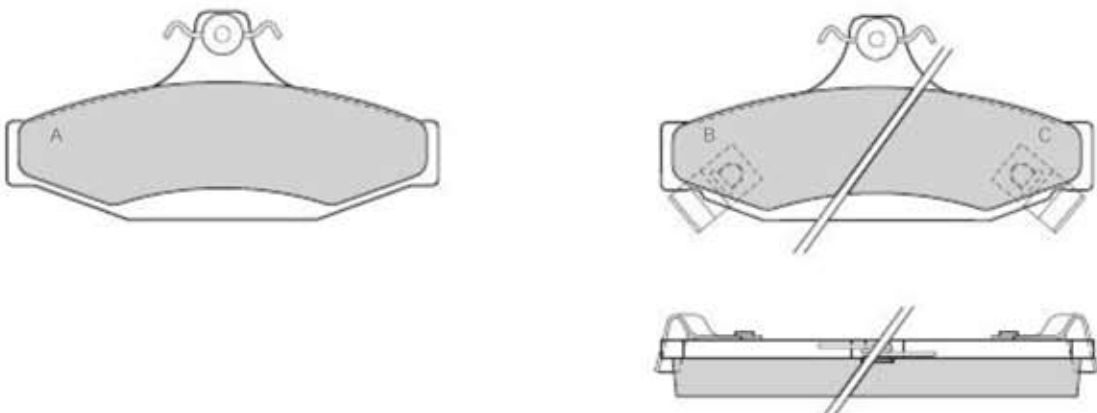

0955	SSANGYONG	LUCAS	X	169,5	A-B 50 C-D 59	1b	1A-1B 1C-1D	2	260
------	-----------	-------	---	-------	------------------	----	----------------	---	-----



0956	SSANGYONG	LUCAS	X	114	A 55 B-C 54	15,2	2A 1B-1C		
------	-----------	-------	---	-----	----------------	------	-------------	--	--

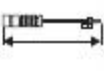

									
0957	VOLKSWAGEN	LUCAS	X	94,9	51	17,3	2A-2B	2	210

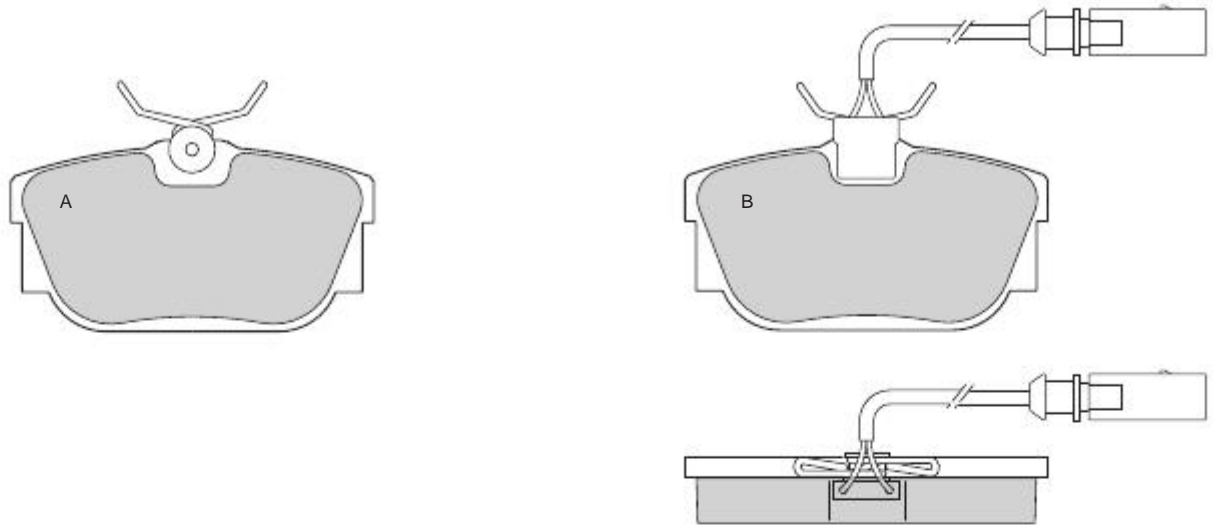



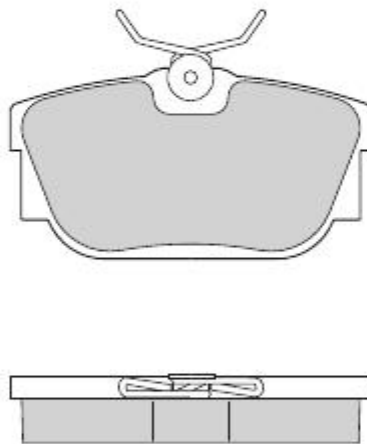



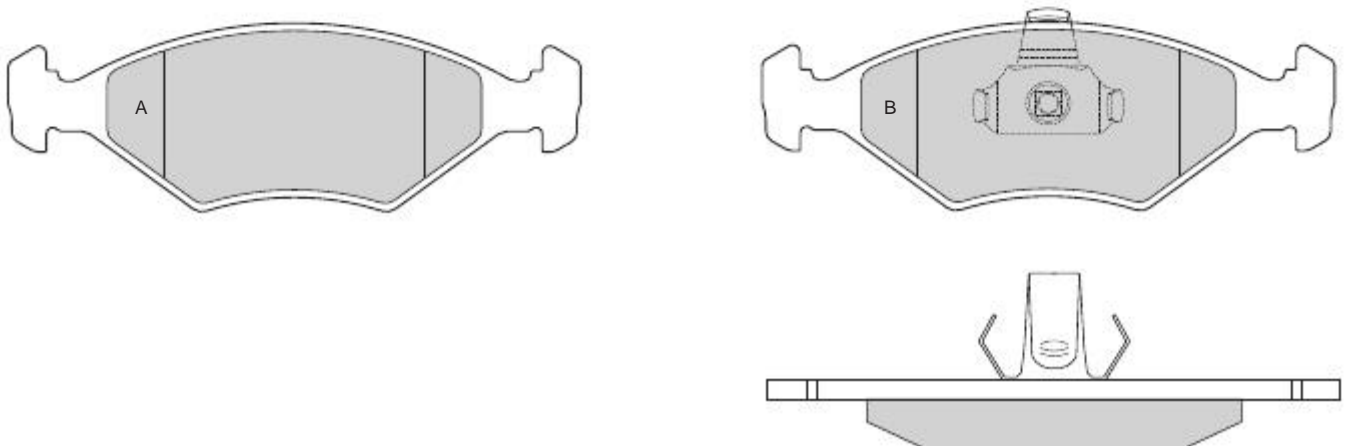



0958	VOLKSWAGEN	LUCAS	X	94,9	51	17,3	4		
-------------	------------	-------	---	------	----	------	---	--	--



0959	FIAT	ATE	X	151,3	50	18	2A-2B		
-------------	------	-----	---	-------	----	----	-------	--	--



									
0960	LAND ROVER	LUCAS	X	131,4	61,8	18,2	4		

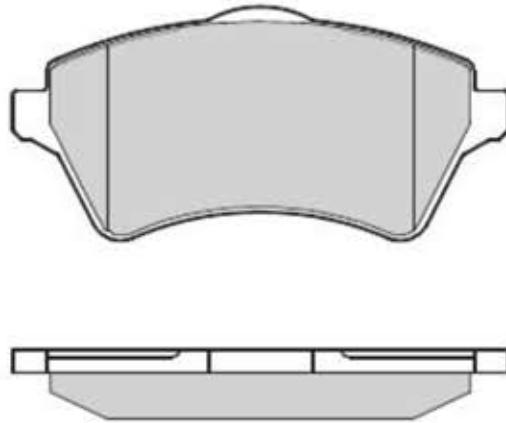



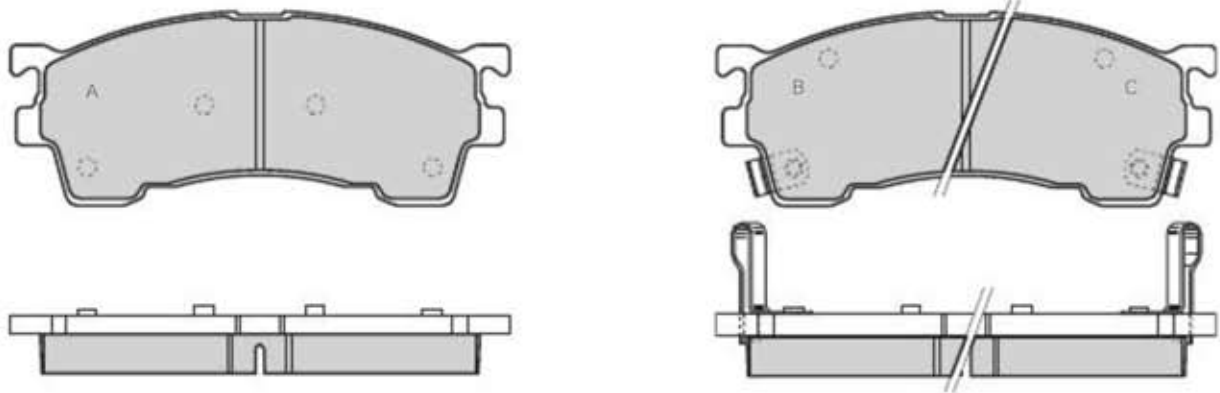







0961	FORD - MAZDA	SUMITOMO	X	132	51,5	A 15,5 B-C 16,5	2A 1B-1C		
------	--------------	----------	---	-----	------	--------------------	-------------	--	--



0962	TOYOTA - LEXUS	SUMITOMO	X	57,2	63,8	15,5	4		
------	----------------	----------	---	------	------	------	---	--	--



									
0963	TOYOTA	AKEBONO	X	117,5	58,7	17,3	4		

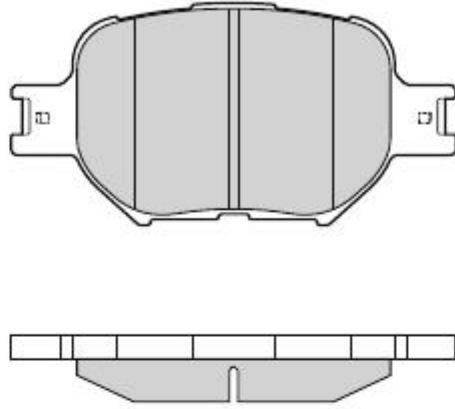



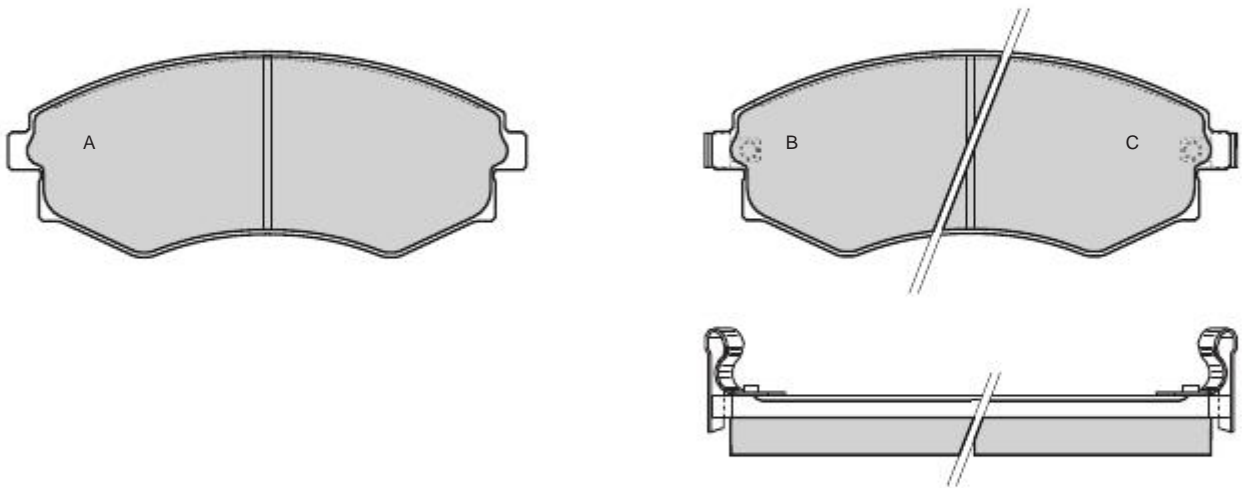



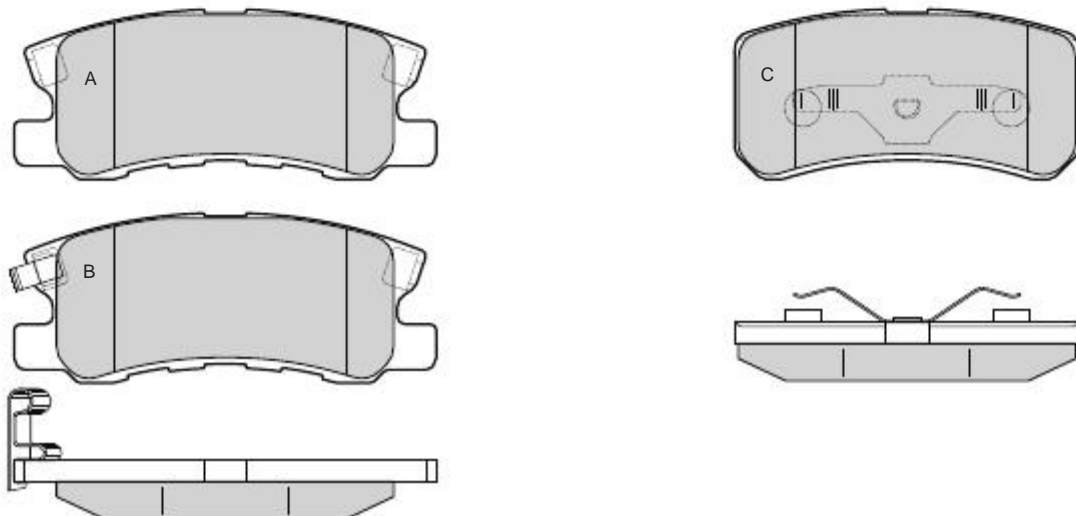

0964	KIA - HYUNDAI	AKEBONO	X	137,1	54,4	15,8	2A 1B-1C		
-------------	---------------	---------	---	-------	------	------	-------------	--	--



0965	MITSUBISHI	AKEBONO	X	A+B 111,5 C 91	45	15,3	2A 1B-1C		
-------------	------------	---------	---	-------------------	----	------	-------------	--	--

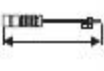

									
0966	HYUNDAI	MANDO	X	98,8	41	15	2A 1B-1C		

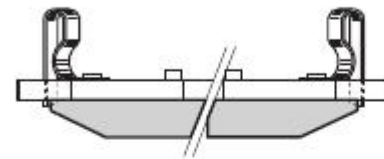
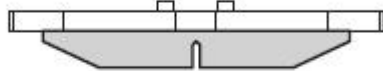
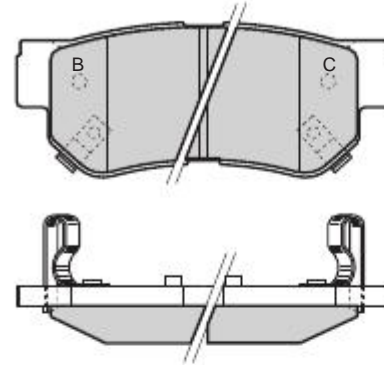
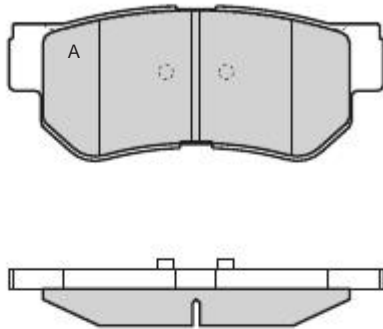



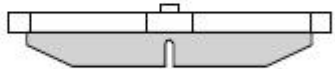
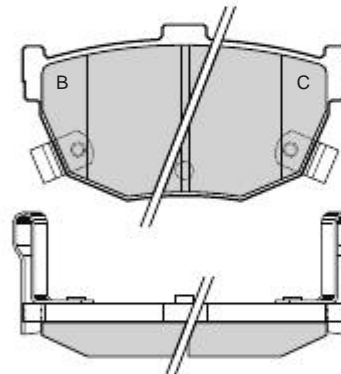
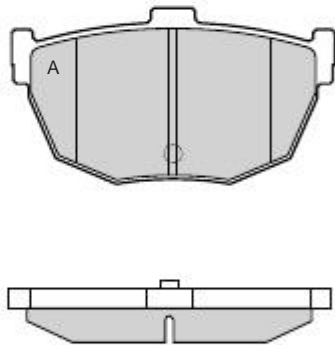



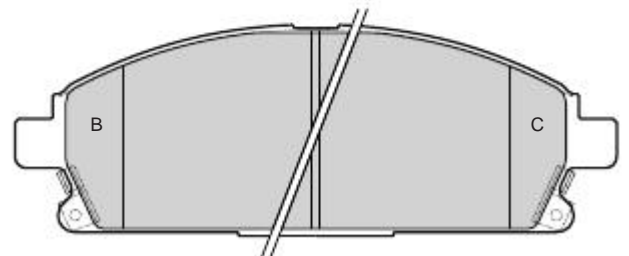
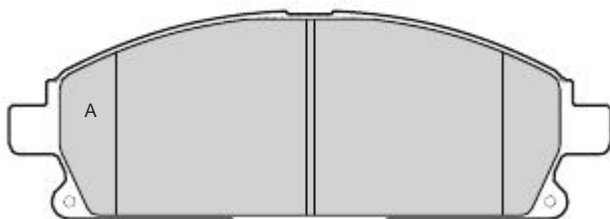



0967	HYUNDAI - MITSUBISHI	SUMITOMO	X	85,3	46,5	14	2A 1B-1C		
-------------	----------------------	----------	---	------	------	----	-------------	--	--



0968	NISSAN	SUMITOMO	X	159	56	16,4	2A 1B-1C		
-------------	--------	----------	---	-----	----	------	-------------	--	--



									
0969	MERCEDES	KELSEY-HAYES	X	140	A-C-U 50 B 60	16,6	1A-1B 1C-1D	1	240

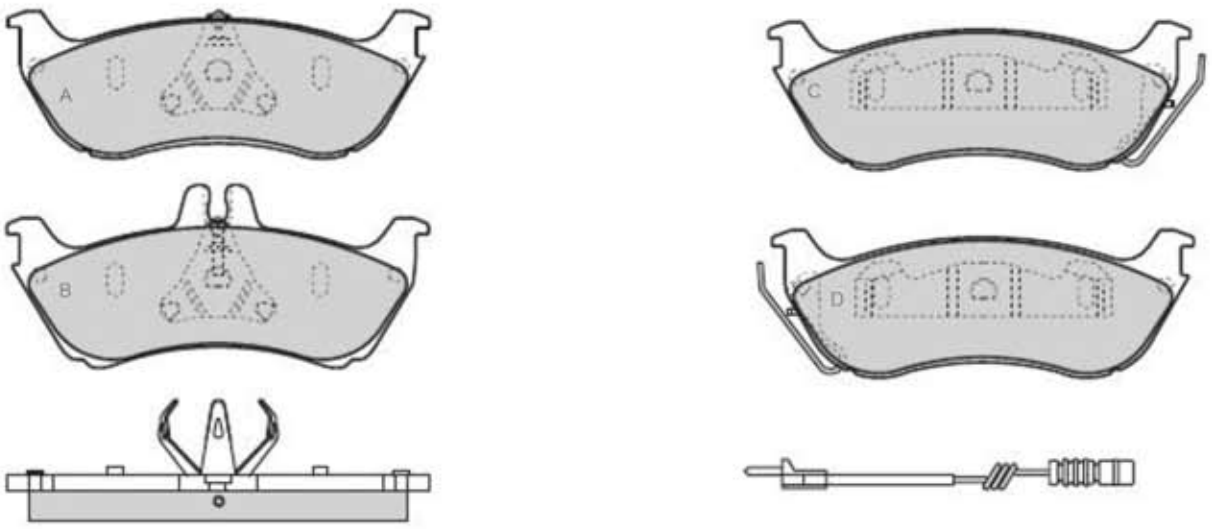



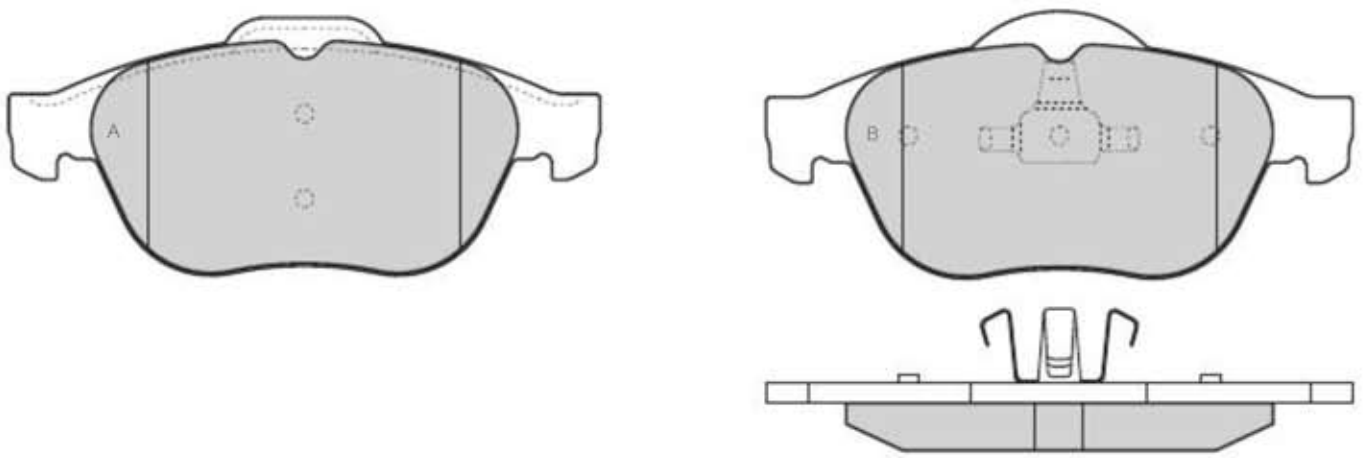



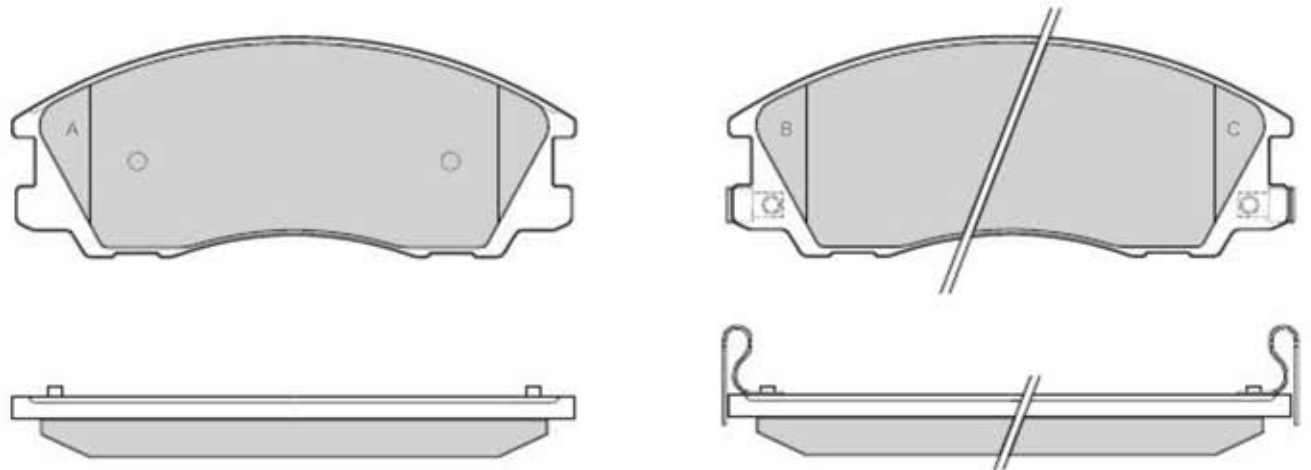



0970	RENAULT	ATE	X	A 156,3 B 155,1	A 68,5 B 71	18	2A-2B		
------	---------	-----	---	--------------------	----------------	----	-------	--	--



0971	HYUNDAI	MANDO	X	148,9	58,1	16	2A 1B-1C		
------	---------	-------	---	-------	------	----	-------------	--	--



									
0972	PEUGEOT	BOSCH	X	136,8	57,6	19,3	4		

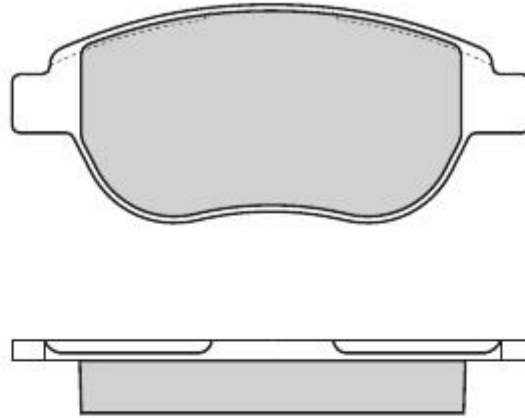



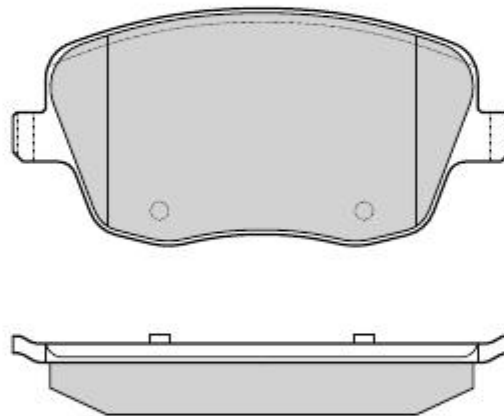



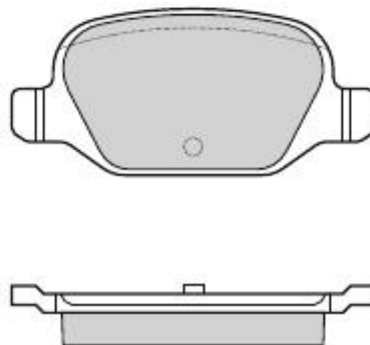



0973	SKODA	LUCAS	X	131,4	62,7	18,8	4		
-------------	-------	-------	---	-------	------	------	---	--	--



0974	FIAT	LUCAS	X	95,8	43,9	13,7	4		
-------------	------	-------	---	------	------	------	---	--	--



									
0975	NISSAN - OPEL - RENAULT VAUXHALL	BOSCH	X	138,7	79,7	17,6	4		

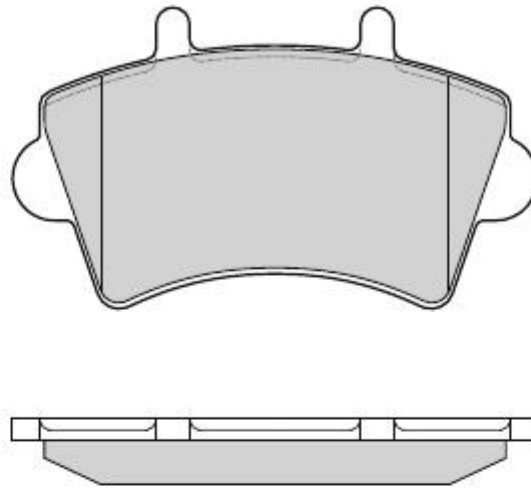



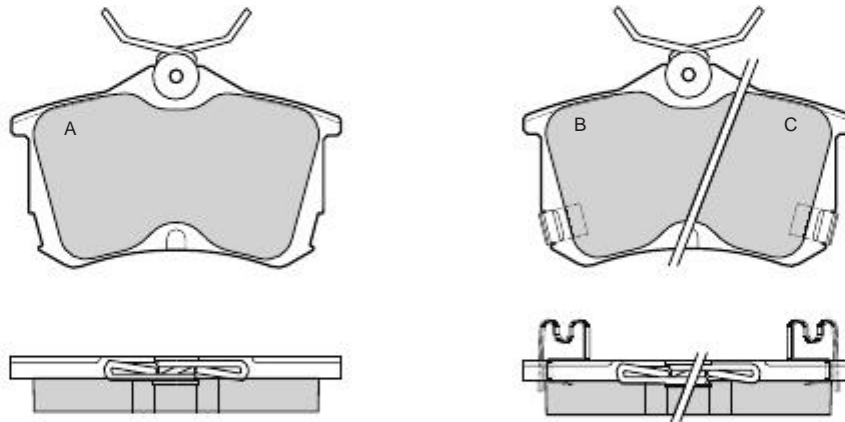



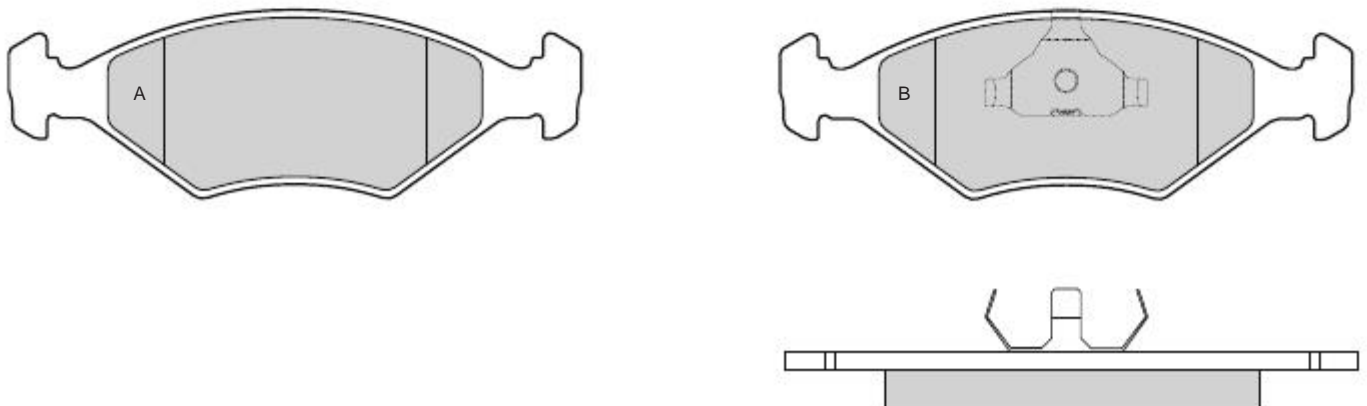













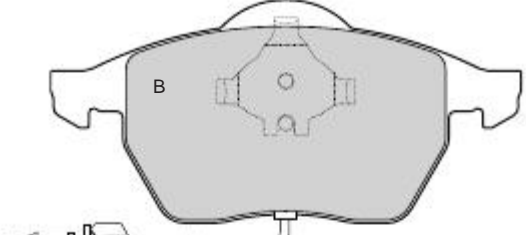
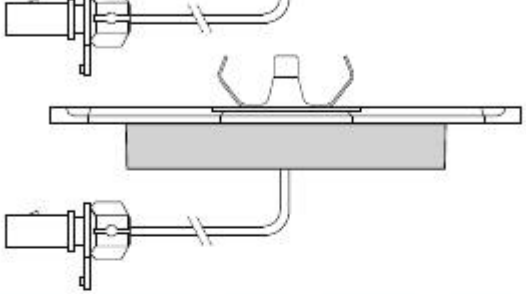
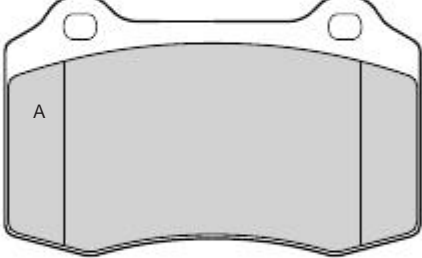
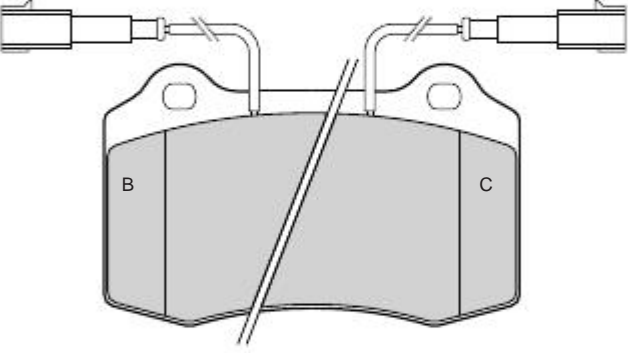
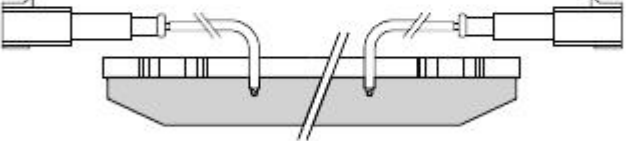

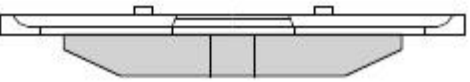
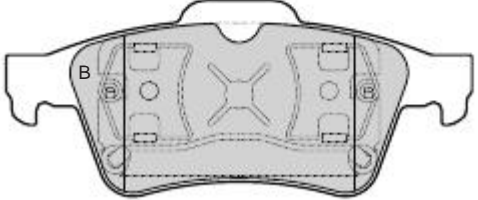
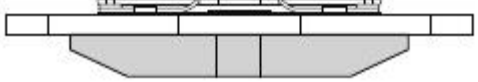

0976	HONDA	LUCAS	X	87	52,9	14,4	2A 1B-1C		
------	-------	-------	---	----	------	------	-------------	--	--



0977	VOLKSWAGEN	ATE	X	151,3	50	15,5	2A-2B		
------	------------	-----	---	-------	----	------	-------	--	--

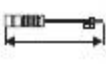

									
0978	FORD - SEAT VOLKSWAGEN	ATE		156,3	74,2	A 19,5 B 20,5	2A-2B	2	200
<div style="display: flex; justify-content: space-around;"> <div style="text-align: center;">  <p>A</p>  </div> <div style="text-align: center;">  <p>B</p>  </div> </div>									
0979	ALFA ROMEO - DODGE FIAT - LANCIA	BREMBO	X	109,7	69,3	17,8	2A 1B-1C	2	300
<div style="display: flex; justify-content: space-around;"> <div style="text-align: center;">  <p>A</p> </div> <div style="text-align: center;">  <p>B C</p>  </div> </div>									
0980	NISSAN - OPEL - RENAULT SAAB - VAUXHALL	ATE	X	123	51,8	16	2A-2B		
<div style="display: flex; justify-content: space-around;"> <div style="text-align: center;">  <p>A</p>  </div> <div style="text-align: center;">  <p>B</p>  </div> </div>									

									
0981	RENAULT	ATE	X	A 156,3 B 155,1	A 66,4 B 68,8	18	2A-2B		

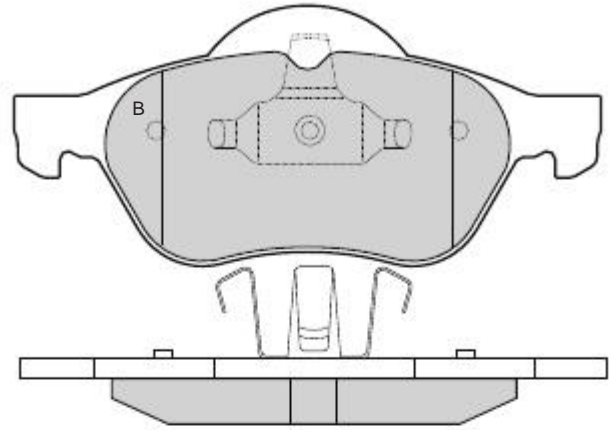
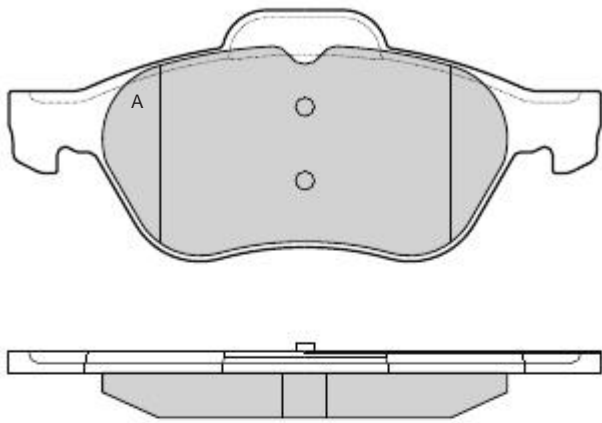



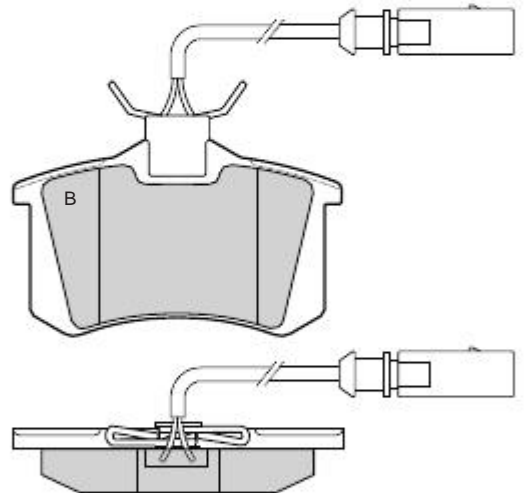
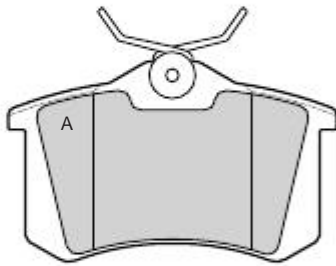



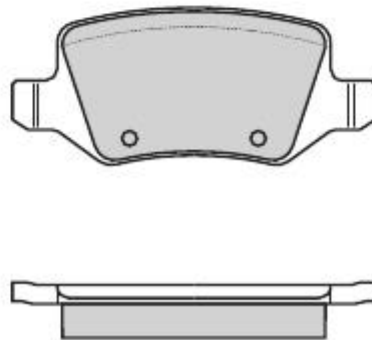



0982	SEAT - VOLKSWAGEN	GIRLING	X	87	52,8	17	3A-1B	1	200
-------------	-------------------	---------	---	----	------	----	-------	---	-----



0983	MERCEDES	LUCAS	X	95,7	41,5	14	4		
-------------	----------	-------	---	------	------	----	---	--	--



									
0984	AUDI - SEAT - SKODA VOLKSWAGEN	ATE	X	156,3	74,2	A 19,5 B 20,5	2A 1B-1C	1	160

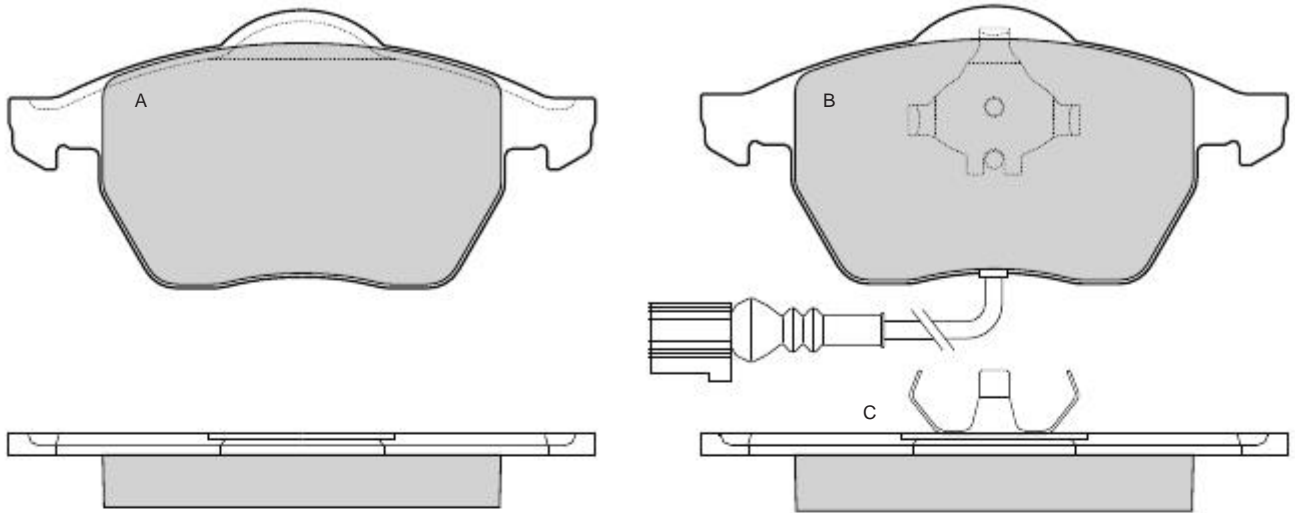



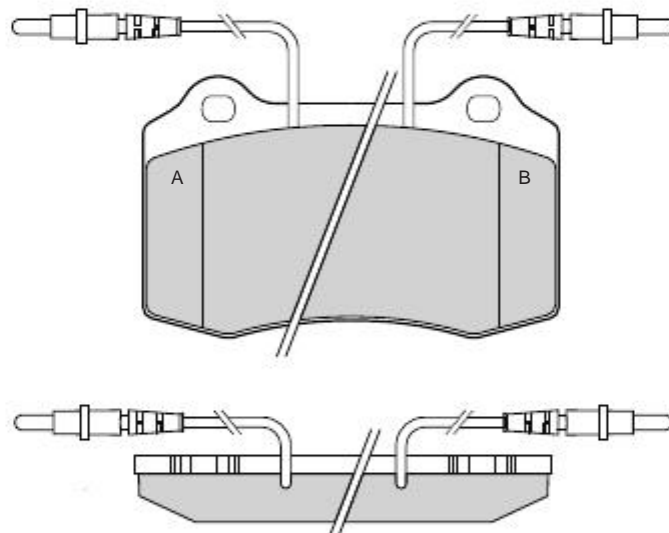



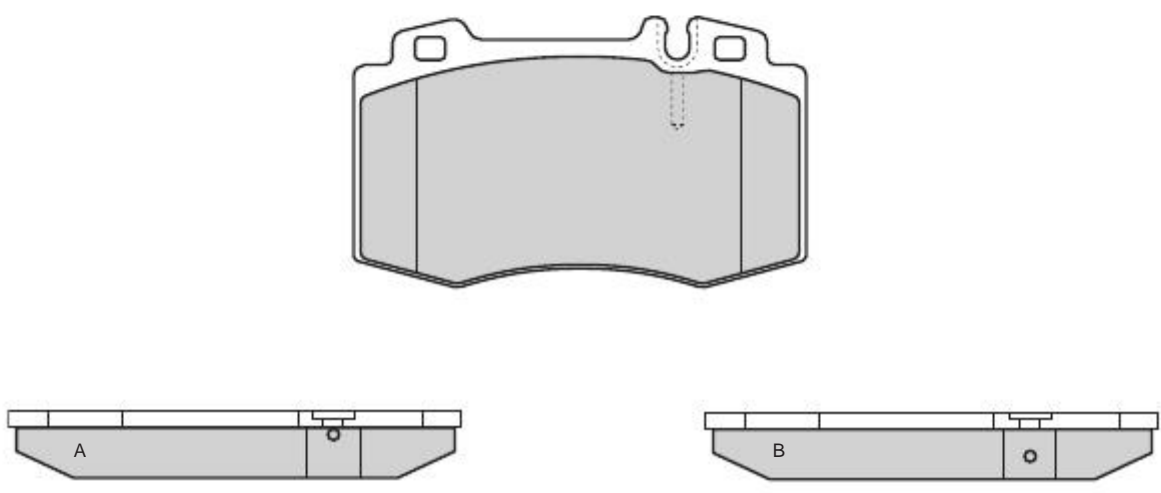



0985	PEUGEOT	BREMBO	X	109,7	69,3	17,8	2A-2B	4	370
------	---------	--------	---	-------	------	------	-------	---	-----



0986	MERCEDES	BREMBO	X	119,5	71,4	17,7	2A-2B		
------	----------	--------	---	-------	------	------	-------	--	--



									
0987	OPEL - VAUXHALL	LUCAS	X	95,6	43,9	13,7	2A 1B-1C		

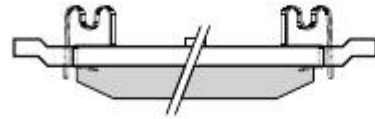
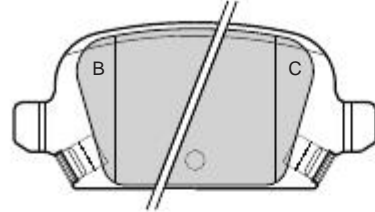
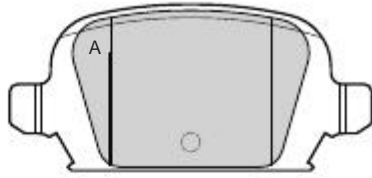



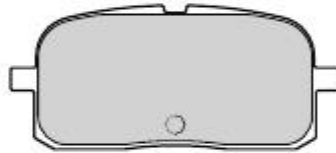



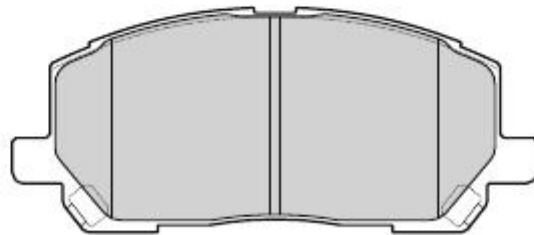



0988	TOYOTA	SUMITOMO	X	86,9	38	12,5	4		
-------------	--------	----------	---	------	----	------	---	--	--



0989	TOYOTA	AKEBONO	X	138,8	59,5	17	4		
-------------	--------	---------	---	-------	------	----	---	--	--



									
0990	MAZDA	SUMITOMO	X	123	58,5	15,4	4		

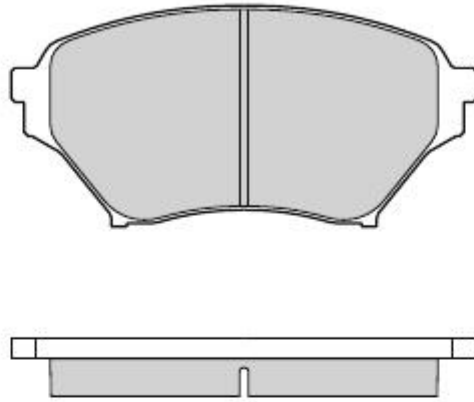



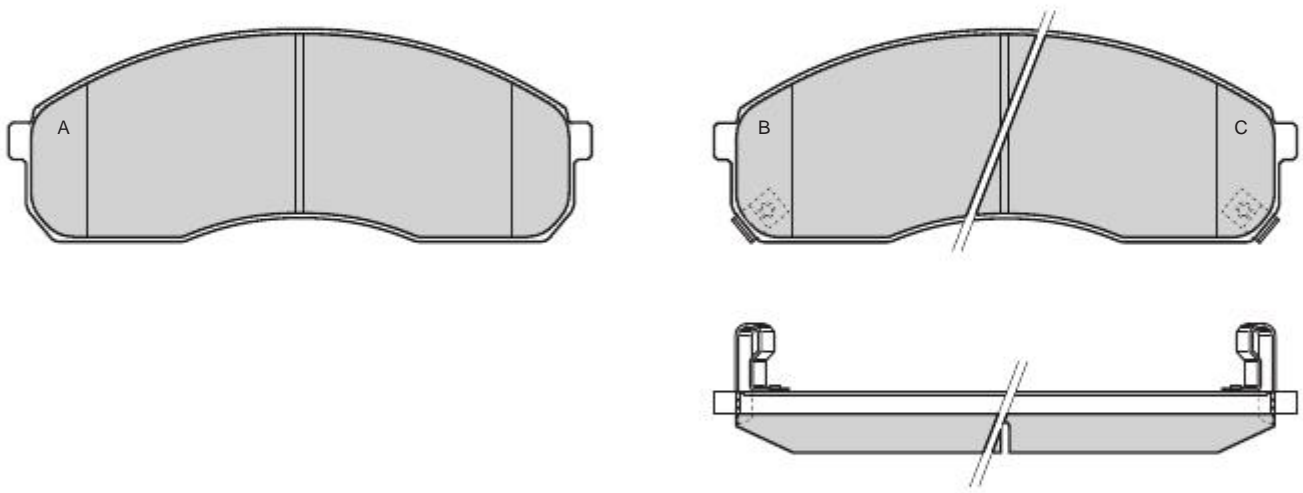



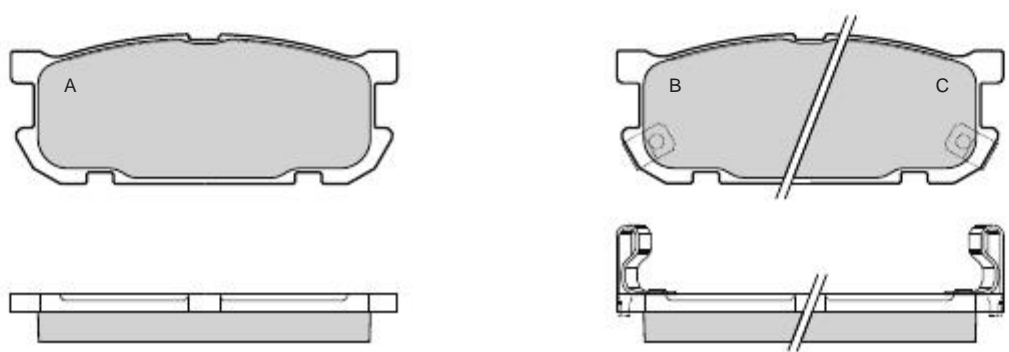

0991	KIA	SUMITOMO	X	154	56,3	16,2	2A 1B-1C		
------	-----	----------	---	-----	------	------	-------------	--	--



0992	MAZDA	AKEBONO	X	102	39,4	12,5	2A 1B-1C		
------	-------	---------	---	-----	------	------	-------------	--	--

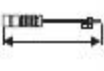

									
0993	TOYOTA	SUMITOMO	X	123	60,3	17,4	2A-2B		

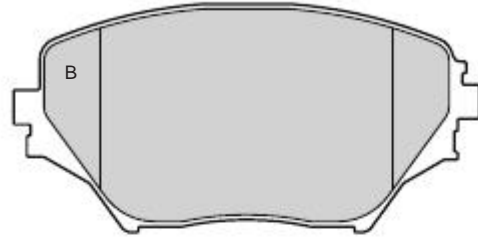
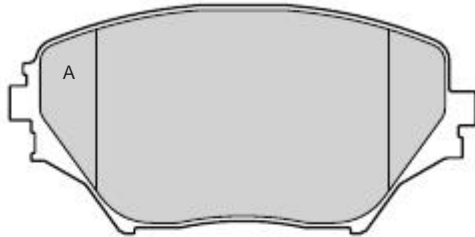



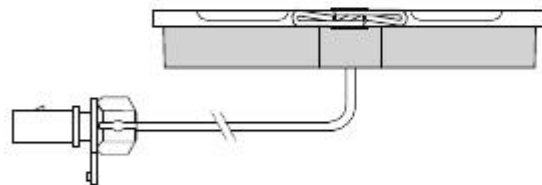
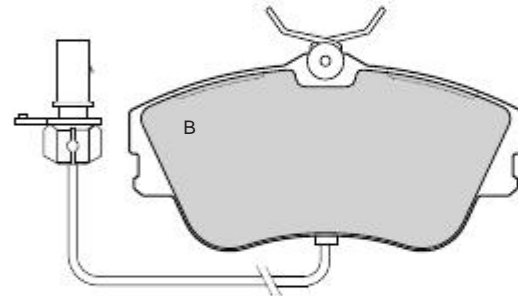
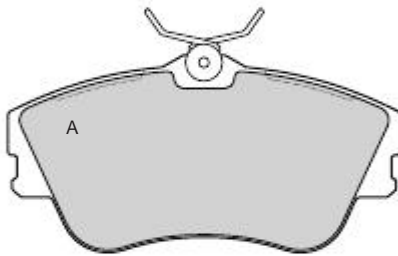



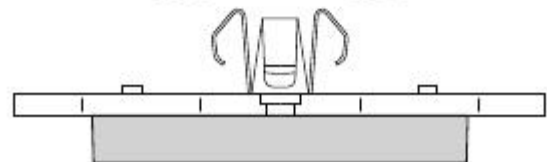



0994	VOLKSWAGEN	GIRLING	X	129,5	65,20	19	3A-1B	1	210
-------------	------------	---------	---	-------	-------	----	-------	---	-----



0995	MINI (BMW)	ATE	X	140,2	A 59,7 B 58,6	18,1	2A-2B		
-------------	------------	-----	---	-------	------------------	------	-------	--	--



									
0996	CITROEN - FIAT - PEUGEOT	BREMBO	X	109,6	50	19,9	4		





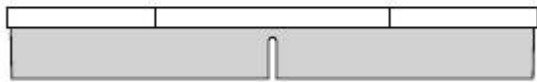
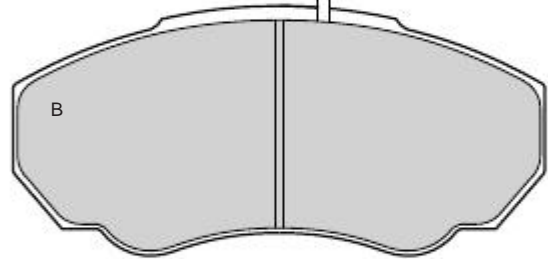
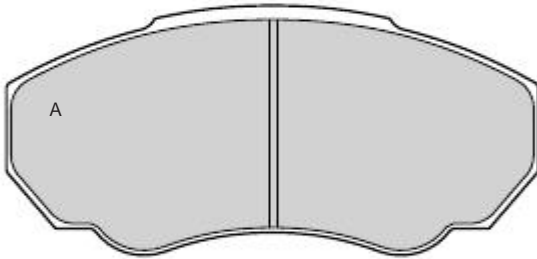



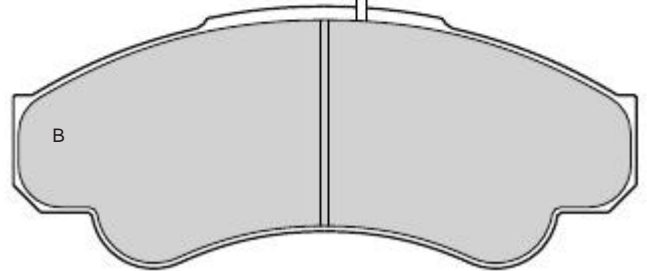
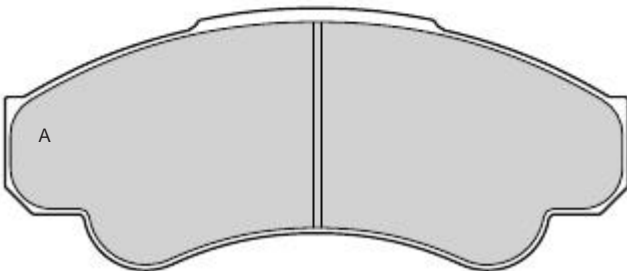

0997	CITROEN - FIAT - PEUGEOT	BREMBO	X	140,5	66	19	3A-1B	1	220
-------------	--------------------------	--------	---	-------	----	----	-------	---	-----



0998	CITROEN - FIAT - PEUGEOT	BREMBO	X	164,6	69,3	19,2	3A-1B	1	220
-------------	--------------------------	--------	---	-------	------	------	-------	---	-----

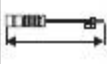

									
0999	MERCEDES	ATE	X	69,2	72,6	16,2	4		

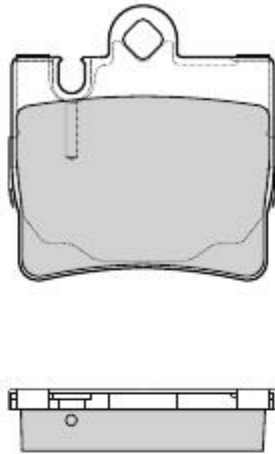

1000	OPEL	GIRLING	X	131,4	A 55,6 B 51,5	17	2A-2B		
------	------	---------	---	-------	------------------	----	-------	--	--

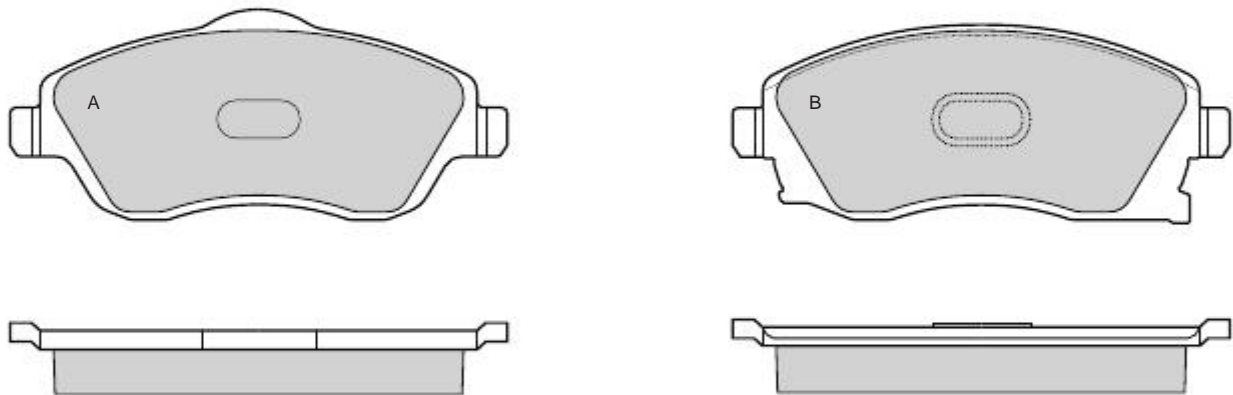

1001	MITSUBISHI	SUMITOMO	X	138,9	58,5	15,4	4		
------	------------	----------	---	-------	------	------	---	--	--

