

1002	LIGIER	ATE	X	89,7	42	10	2A-2B	2	200

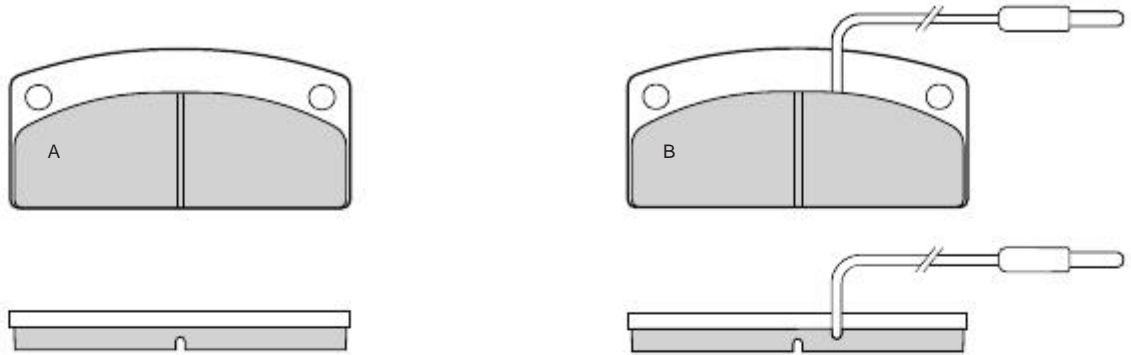

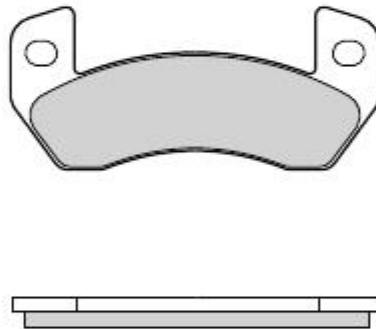

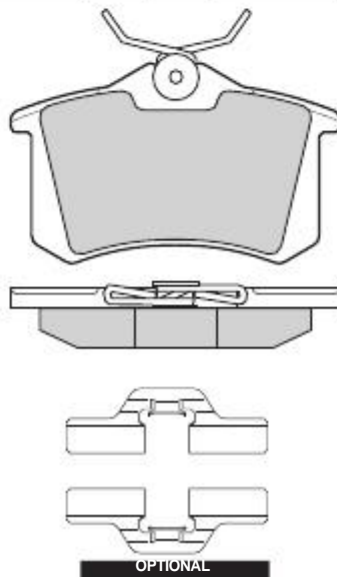







1003	LIGIER	LIGIER	X	97,1	43	8	4		
-------------	--------	--------	---	------	----	---	---	--	--



1004	RENAULT - SEAT VOLKSWAGEN	GIRLING	X	87	52,9	16	4		
-------------	------------------------------	---------	---	----	------	----	---	--	--



									
1005	AUDI - SKODA VOLKSWAGEN	GIRLING	X	87	52,9	12	3A-1B	1	260

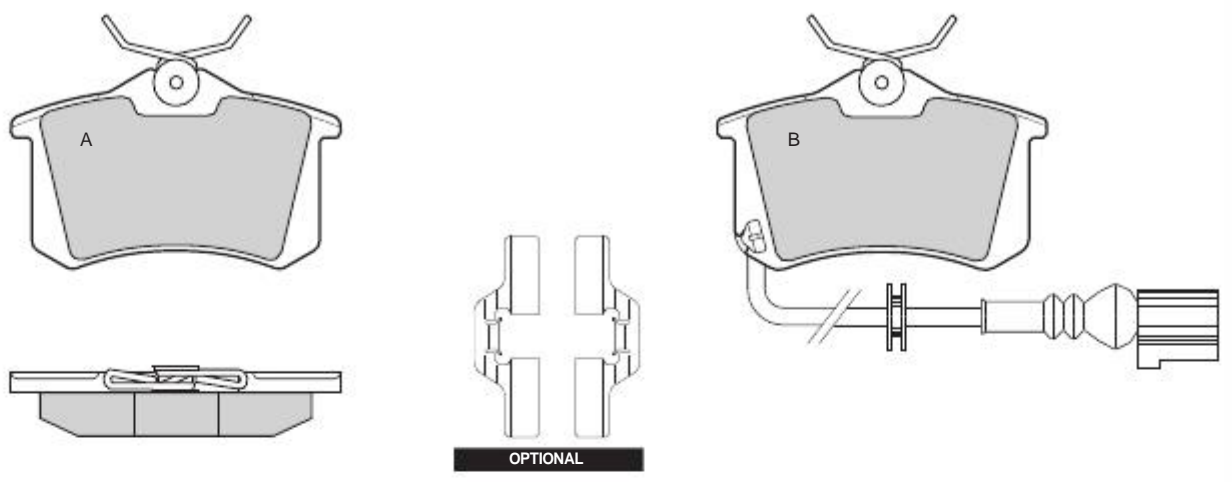



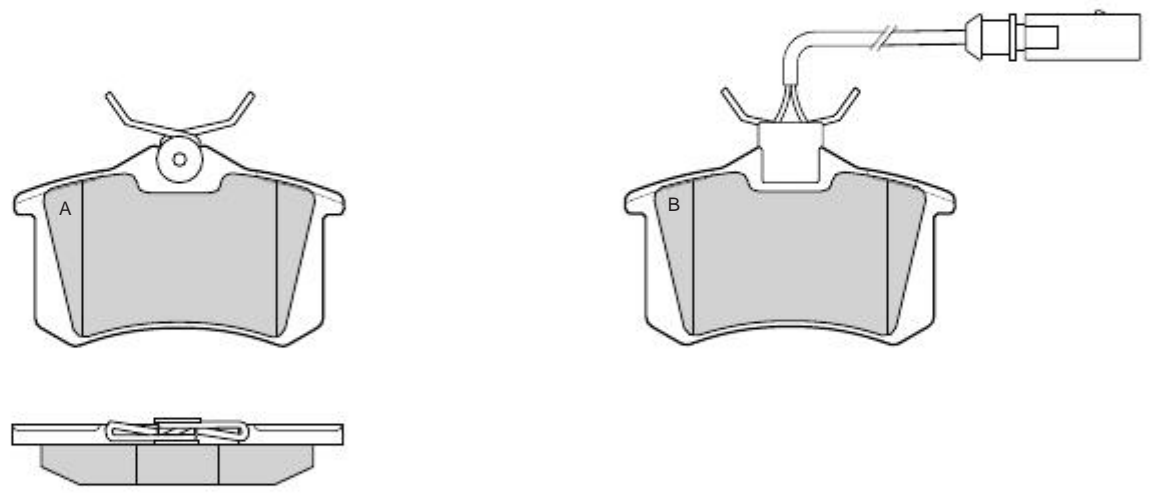



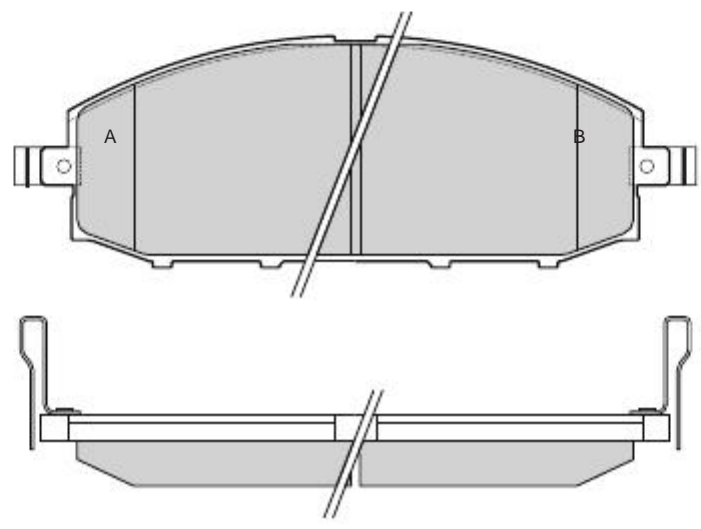



1006	AUDI	GIRLING	X	87	52,9	16	2A-2B	2	340
------	------	---------	---	----	------	----	-------	---	-----



1007	NISSAN	SUMITOMO	X	166	61,3	19	2A-2B		
------	--------	----------	---	-----	------	----	-------	--	--



									
1008	CITROEN	GIRLING	X	122,5	53	19	4		

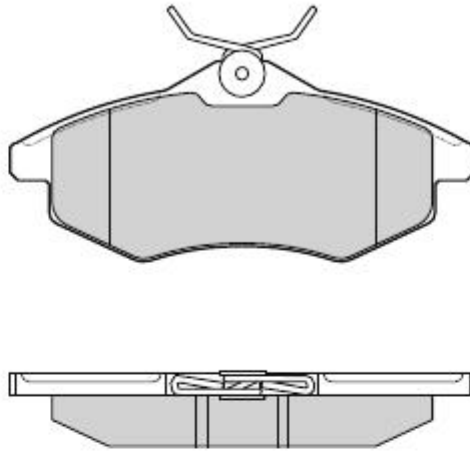



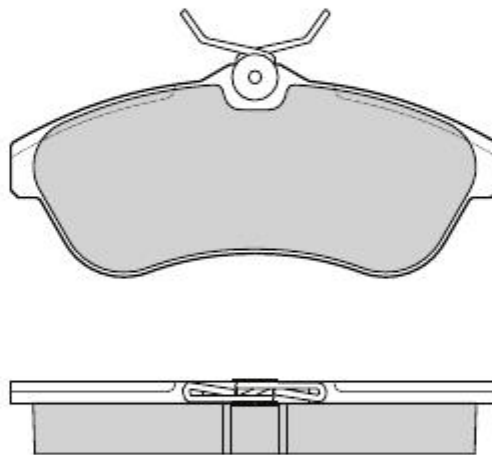



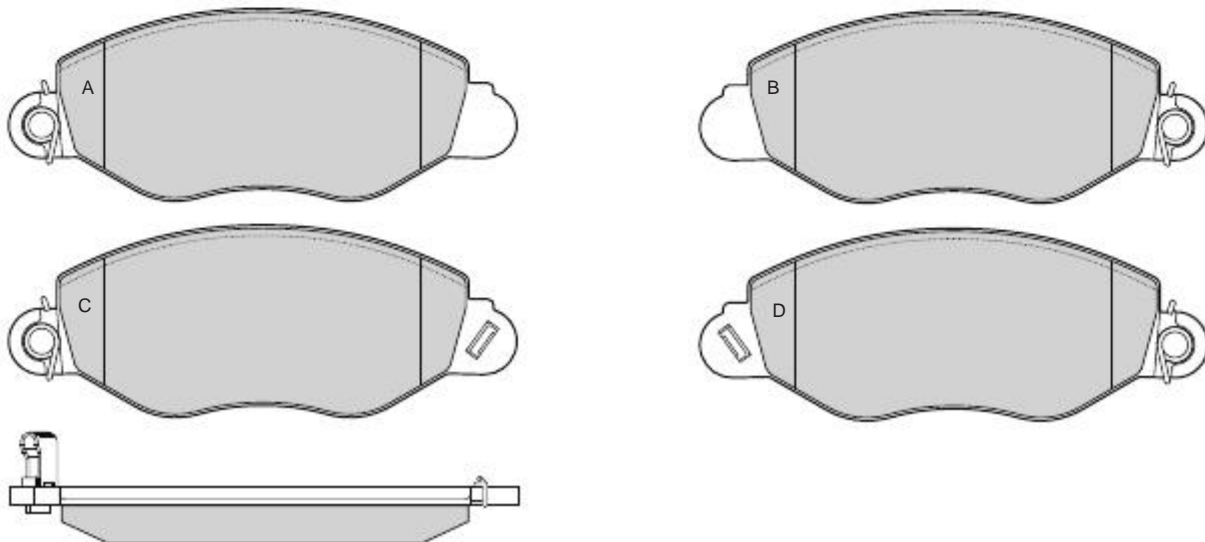



1009	CITROEN	GIRLING	X	128,7	56,1	19	4		
-------------	---------	---------	---	-------	------	----	---	--	--



1010	FORD	BOSCH	X	169	64	18,4	1A-1B 1C-1D		
-------------	------	-------	---	-----	----	------	----------------	--	--



									
1011	OPEL - RENAULT	GIRLING	X	143,8	63	18	4		

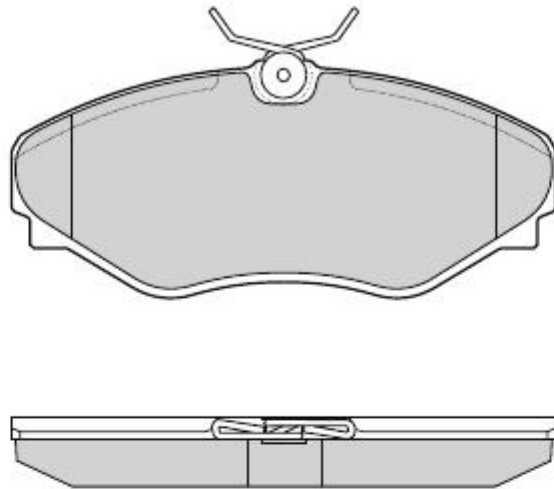



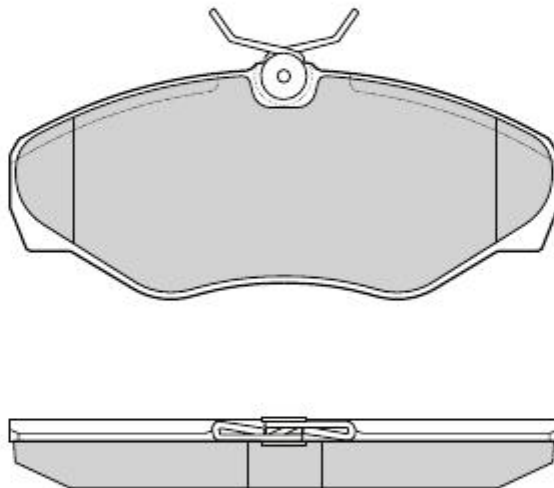



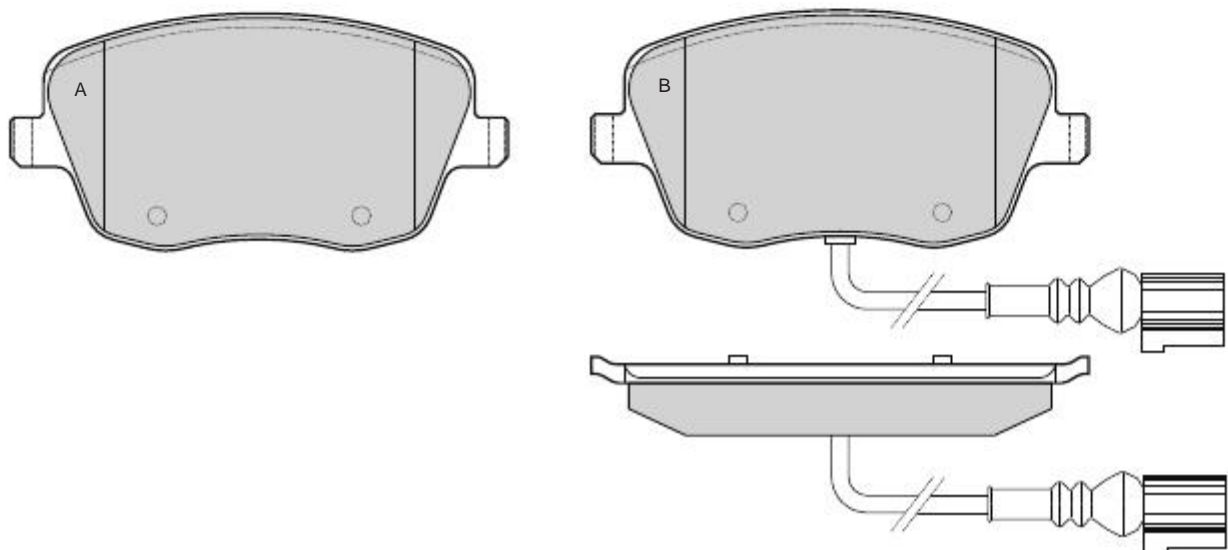



1012	OPEL - RENAULT	GIRLING	X	144,8	62,5	18	4		
-------------	----------------	---------	---	-------	------	----	---	--	--



1013	SEAT - SKODA VOLKSVAGEN	GIRLING	X	131,4	62,7	18,8	3A-1B	1	180
-------------	----------------------------	---------	---	-------	------	------	-------	---	-----



									
1014	OPEL - SAAB	ATE	X	A 156,3 B 155	A 70,7 B 69,6	20,3	2A-2B		

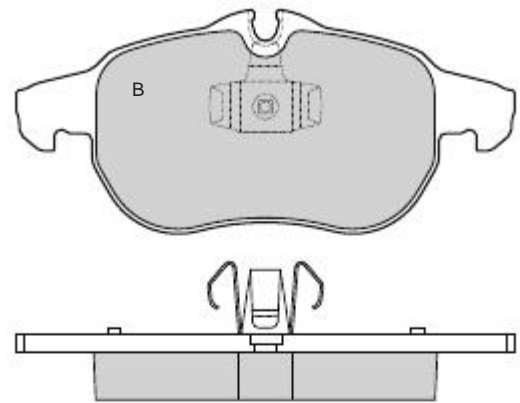
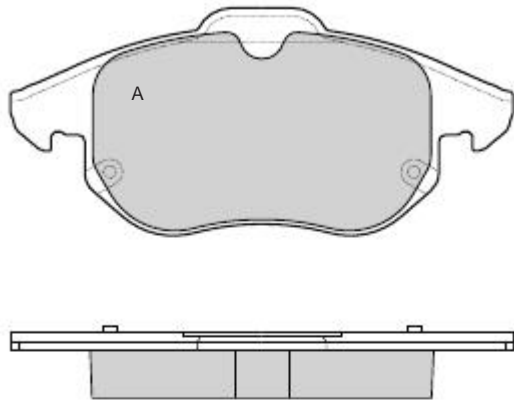



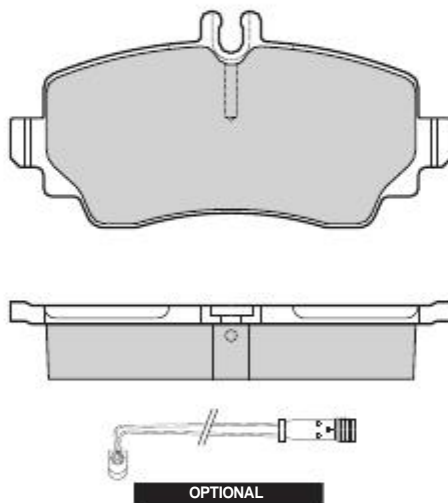



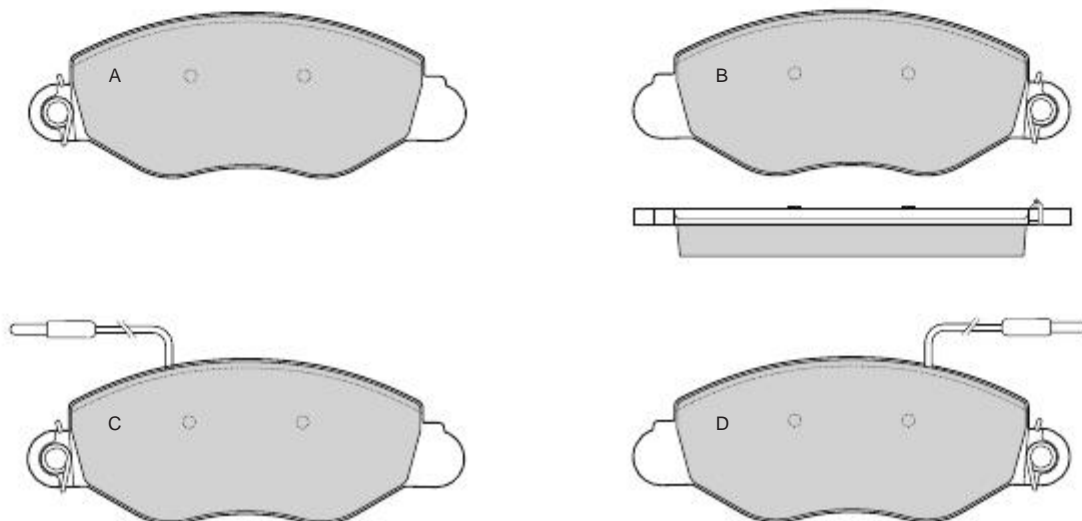

1015	MERCEDES	GIRLING	X	116,5	57,1	19,5	4	1	100
------	----------	---------	---	-------	------	------	---	---	-----



1016	NISSAN	BOSCH	X	169	64	18	1A-1B 1C-1D	2	200
------	--------	-------	---	-----	----	----	----------------	---	-----

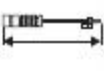

									
1017	SUZUKI	AKEBONO	X	136,4	53,2	17	2A 1B-1C		

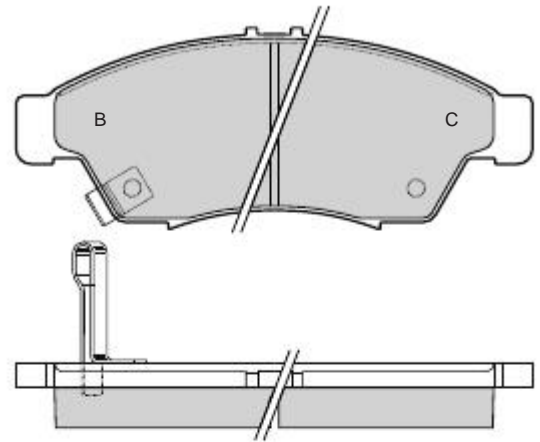
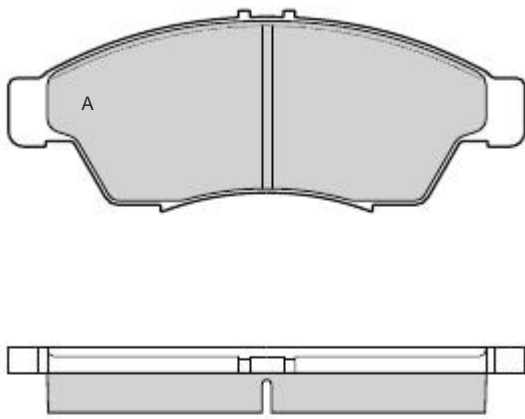



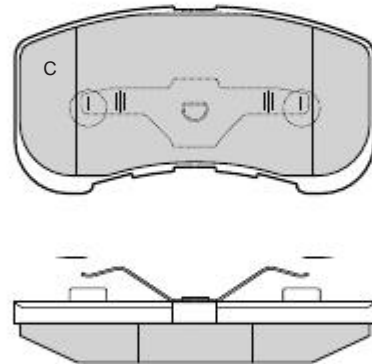
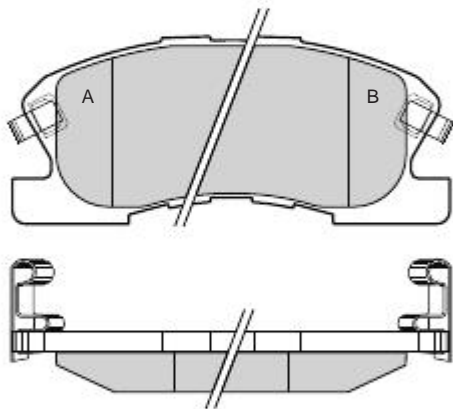



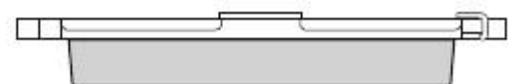

1018	DAIHATSU	AKEBONO	X	A-B 115,5 C 95	49,6	16	1A 1B-2C		
------	----------	---------	---	-------------------	------	----	-------------	--	--



1019	RENAULT	BOSCH	X	131	47,6	18	2A-2B	1	170
------	---------	-------	---	-----	------	----	-------	---	-----

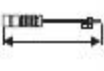

									
1020	MERCEDES	BOSCH	X	136,3	67,8	20	2A-2B	1+1	100

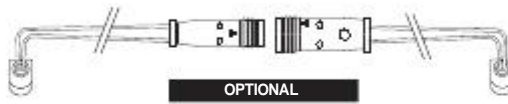
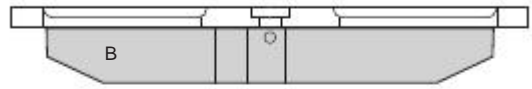
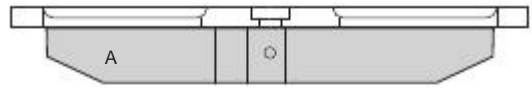
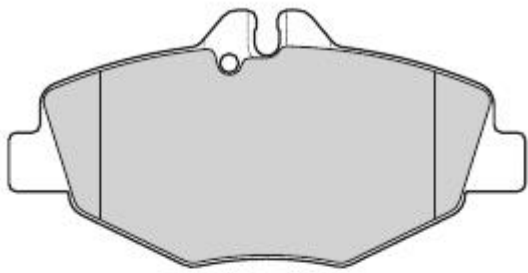



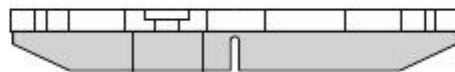
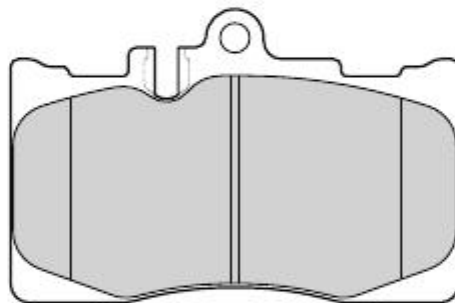



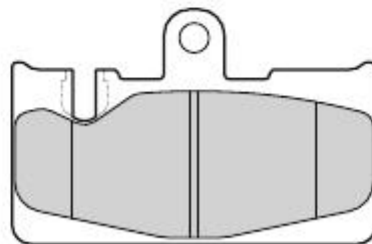

1021	LEXUS	SUMITOMO	X	118,4	77,6	16	4		
-------------	-------	----------	---	-------	------	----	---	--	--



1022	LEXUS	SUMITOMO	X	96,1	62,1	14,9	4		
-------------	-------	----------	---	------	------	------	---	--	--

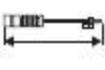

									
1023	LANCIA	GIRLING	X	146,4	59,4	19	4	2	200

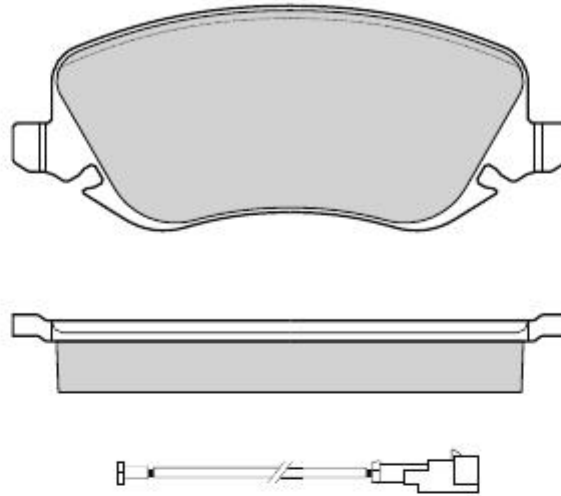



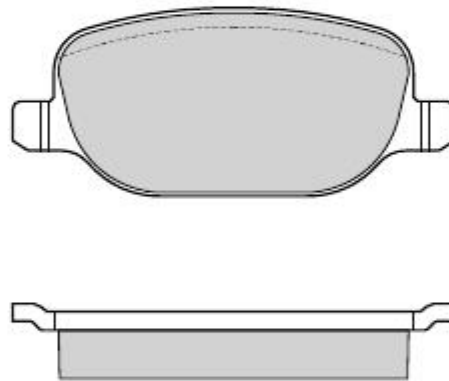



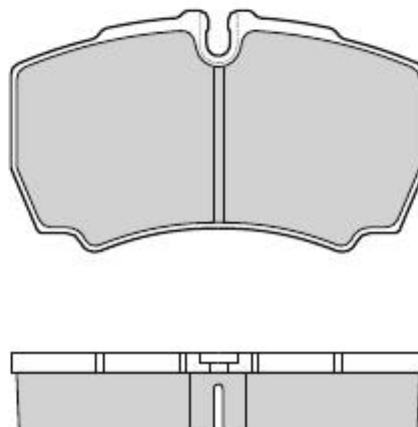

1024	LANCIA	GIRLING	X	116,6	49,8	17,8	4		
-------------	--------	---------	---	-------	------	------	---	--	--



1025	IVECO	BREMBO	X	109,5	63,8	20	4		
-------------	-------	--------	---	-------	------	----	---	--	--

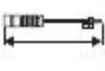

									
1026	DACIA - NISSAN - RENAULT	GIRLING	X	116,3	52,4	17,4	4		

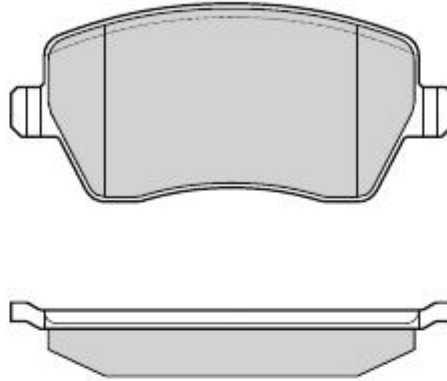



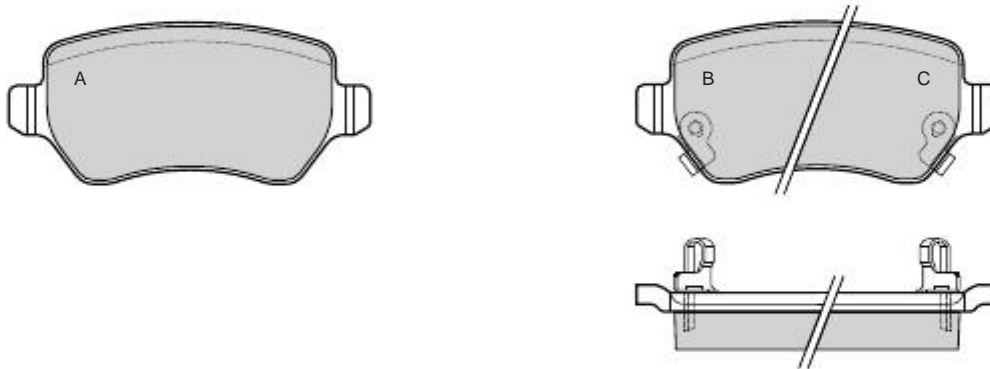



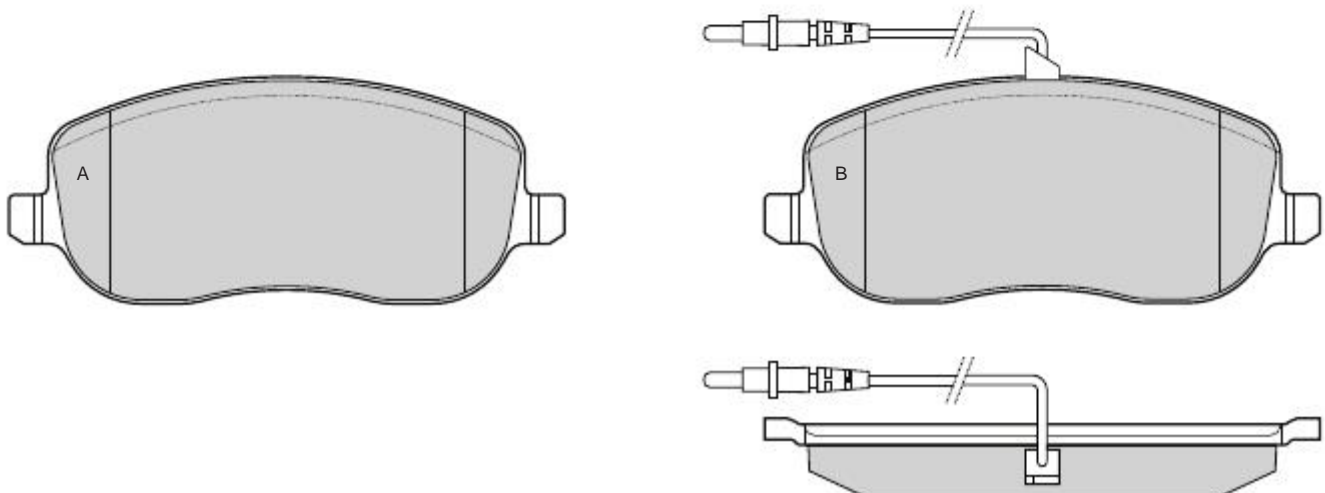

1027	OPEL - VAUXHALL	GIRLING	X	95,4	42,7	15	2A 1B-1C		
-------------	-----------------	---------	---	------	------	----	-------------	--	--



1028	CITROEN - FIAT - LANCIA PEUGEOT	GIRLING	X	146,7	60	19	2A-2B	2	175
-------------	------------------------------------	---------	---	-------	----	----	-------	---	-----

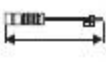

									
1029	MITSUBISHI - KIA							1B-1C	

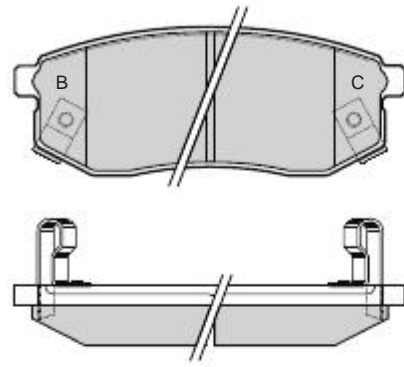
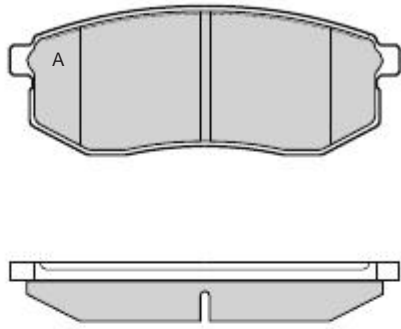



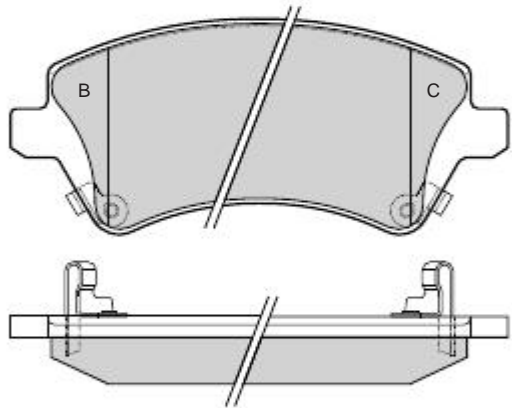
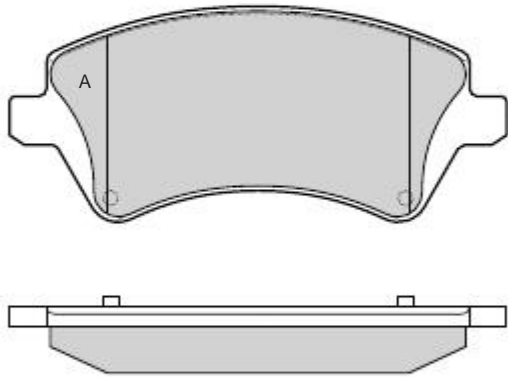



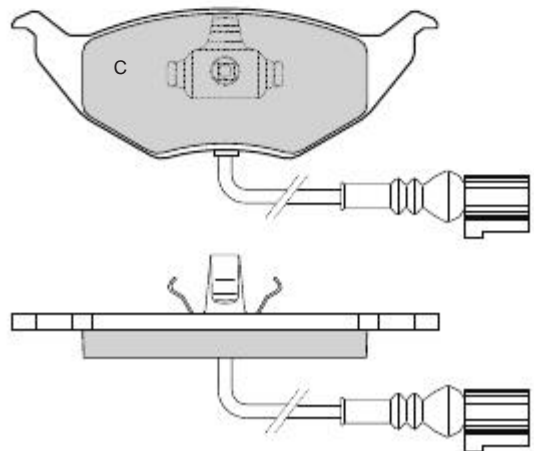
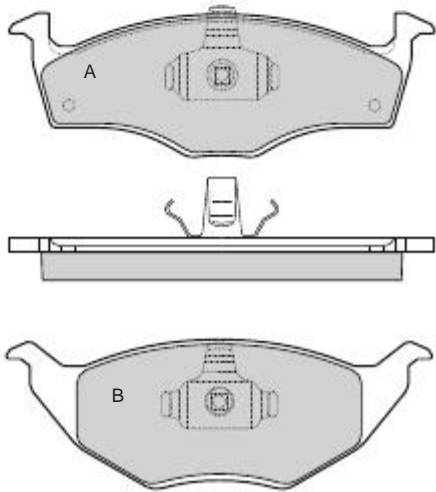



1030	TOYOTA	LUCAS	X		131,4	57,1	17,8	2A 1B-1C	
------	--------	-------	---	--	-------	------	------	-------------	--



1031	SKODA - VOLKSWAGEN	KELSEY-HAYES	X		141,5	A 47,5 B-C 49,7	17,2	2A 1B-1C	1	235
------	--------------------	--------------	---	--	-------	--------------------	------	-------------	---	-----



									
1032	AUDI	KELSEY-HAYES	X	141,5	A 47,5 B-C 49,7	14,3	2A 1B-1C	1	235

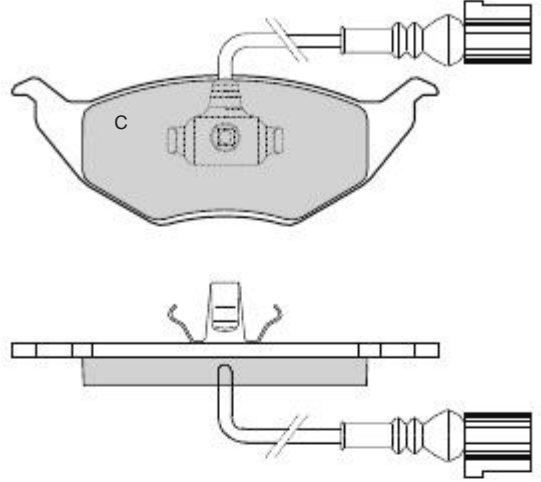
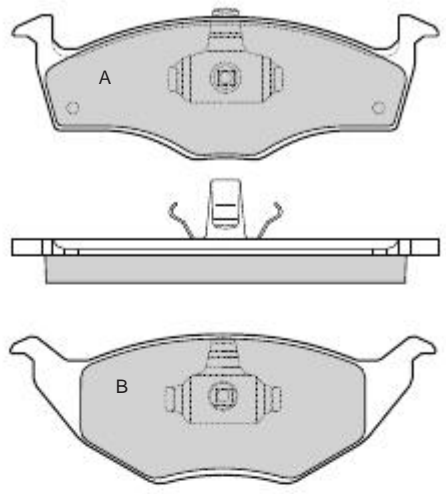



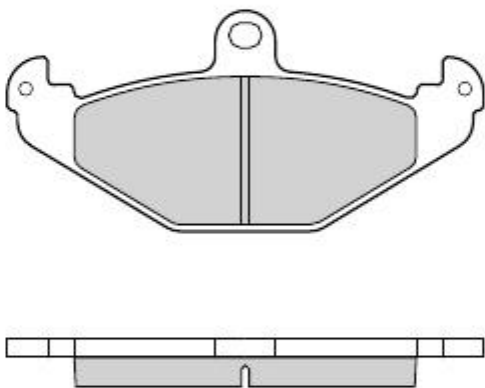



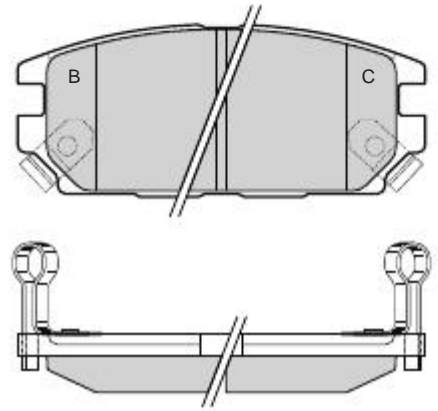
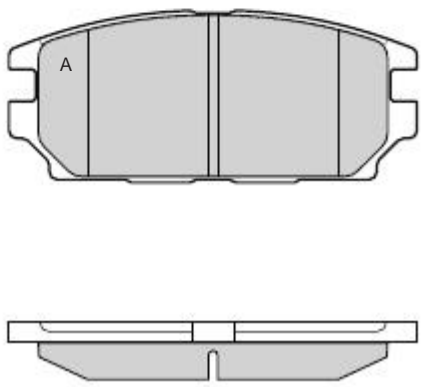



1033	OPEL - VAUXHALL	BREMBO	X	125,8	58,3	12,6	4		
------	-----------------	--------	---	-------	------	------	---	--	--



1034	DODGE - EAGLE						1B-1C		
------	---------------	--	--	--	--	--	-------	--	--



									
1035	LOTUS - OPEL	ATE	X	76,7	65,5	14,4	4		

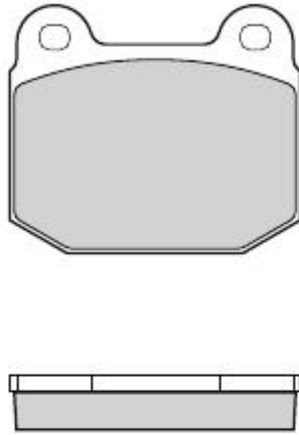



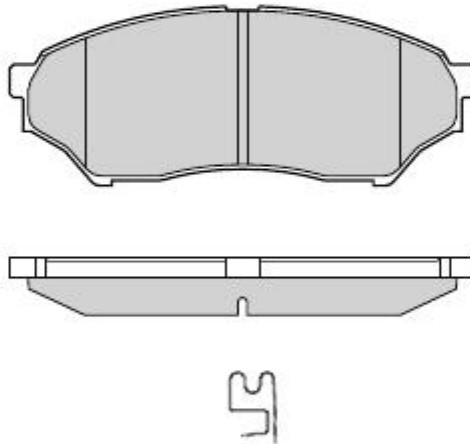



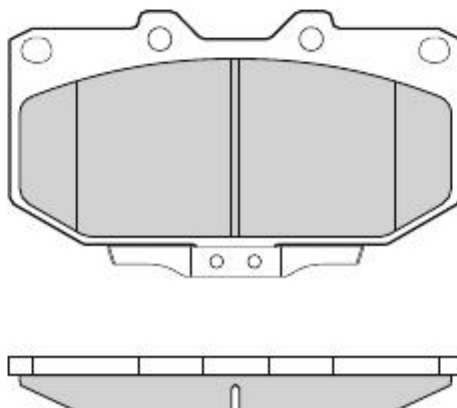

1036	MITSUBISHI	SUMITOMO	X	122,9	47,4	15,4	4		
-------------	------------	----------	---	-------	------	------	---	--	--



1037	SUBARU	SUMITOMO	X	119,2	70,1	14,5	4		
-------------	--------	----------	---	-------	------	------	---	--	--

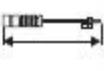

									
1038	CHEVROLET - OPEL	AKEBONO	X	107,8	40,9	14,6	2A 1B-1C		

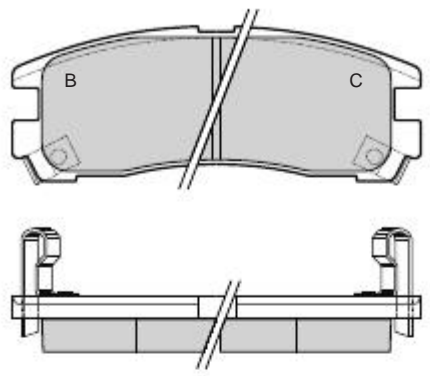
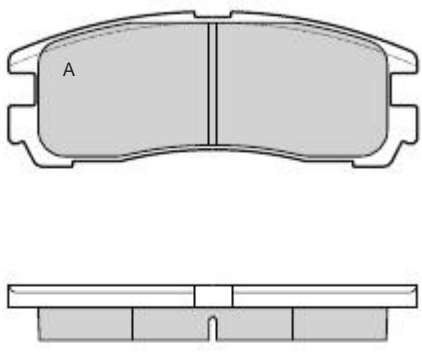



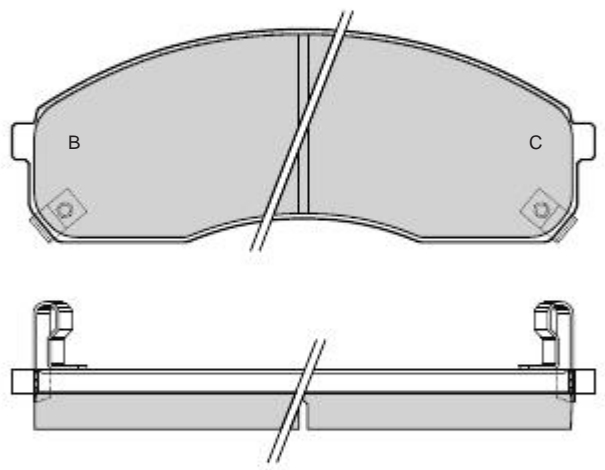
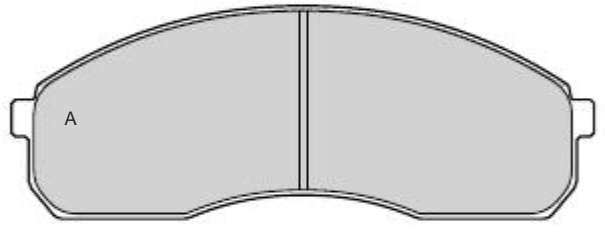



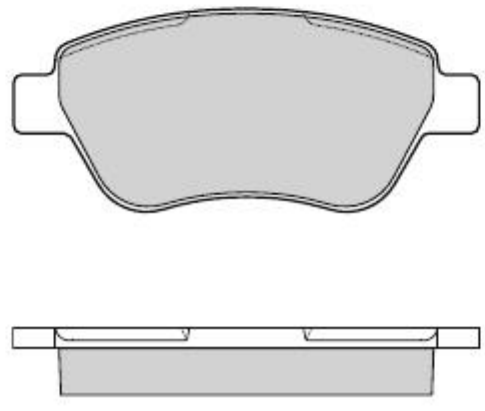

1039	KIA	SUMITOMO	X	154	56,3	15,7	2A 1B-1C		
-------------	-----	----------	---	-----	------	------	-------------	--	--



1040	FIAT	BOSCH	X	122,8	53,6	17,8	4		
-------------	------	-------	---	-------	------	------	---	--	--

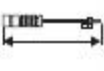

									
1041	HONDA	AKEBONO	X	119	48,7	13,2	2A 1B-1C		

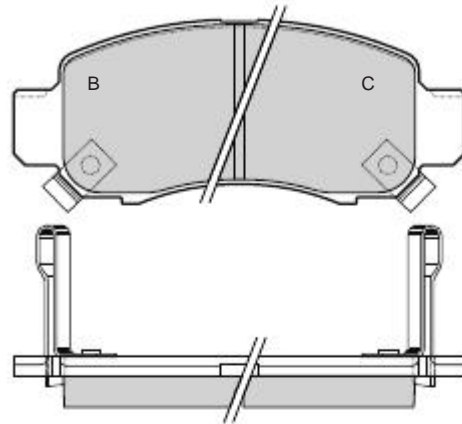
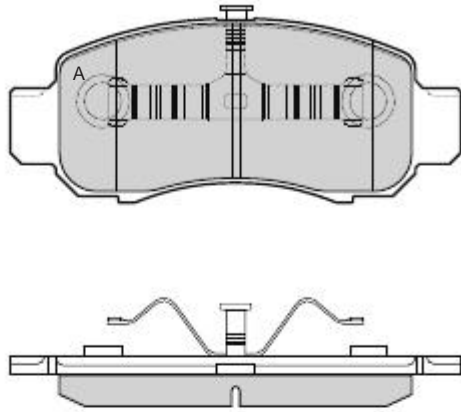



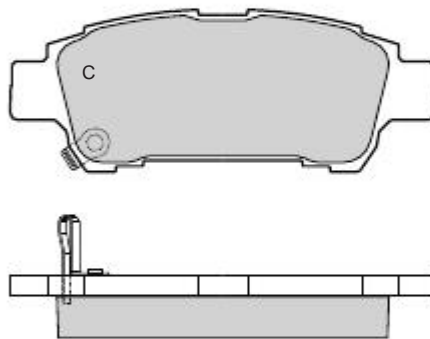
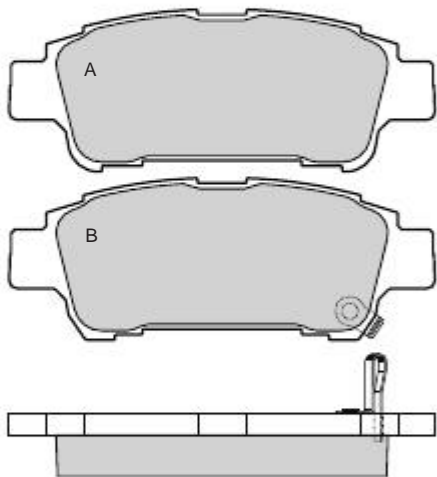



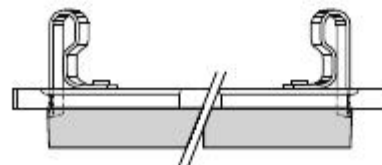
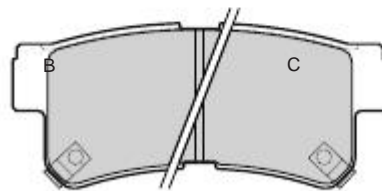
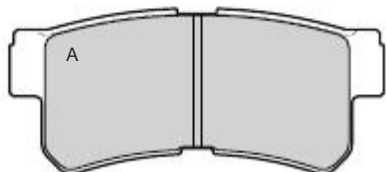



1042	TOYOTA	SUMITOMO	X	112,4	42,8	16,5	2A 1B-1C		
-------------	--------	----------	---	-------	------	------	-------------	--	--



1043	HYUNDAI	MANDO	X	98,8	43,8	15,6	2A 1B-1C		
-------------	---------	-------	---	------	------	------	-------------	--	--



									
1044	ASIA MOTORS	AKEBONO	X	154	63,5	15,5	2A 1B-1C		

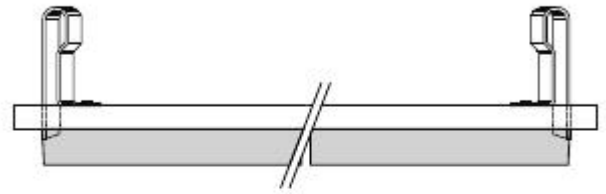
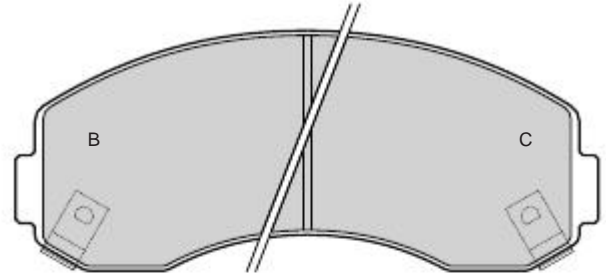
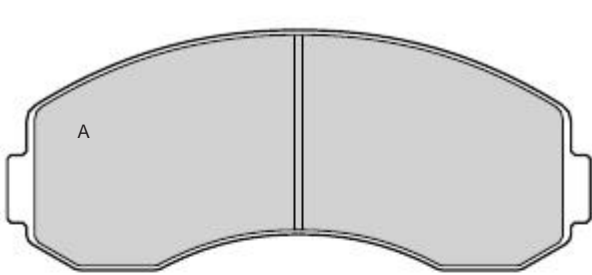



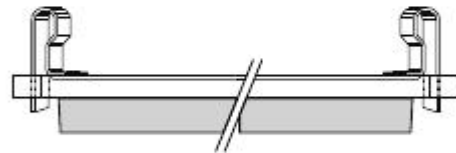
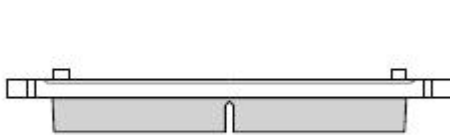
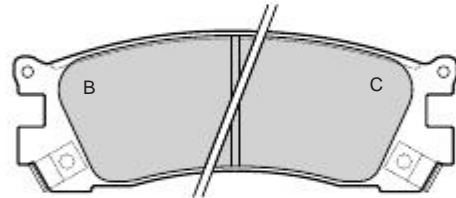
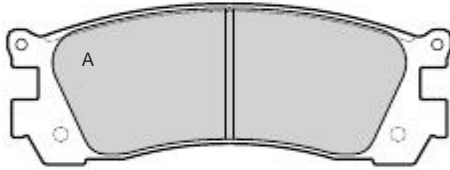



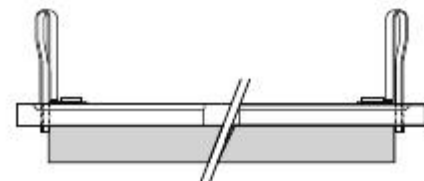
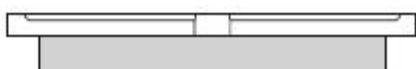
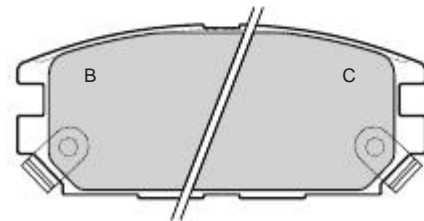

1045	MAZDA	AKEBONO	X	117	42,5	A 14 B-C 15	2A 1B-1C		
------	-------	---------	---	-----	------	----------------	-------------	--	--



1046	MITSUBISHI	AKEBONO	X	107,8	46	15,3	2A 1B-1C		
------	------------	---------	---	-------	----	------	-------------	--	--

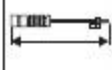

									
1047	SUZUKI	AKEBONO	X	A 102 B 88	40	15	2A-2B		

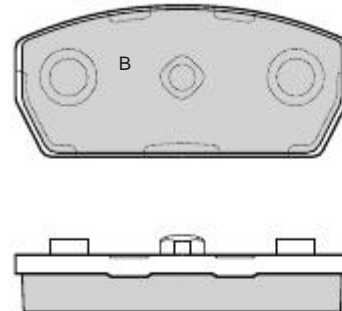
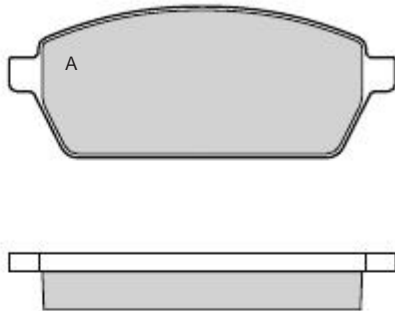



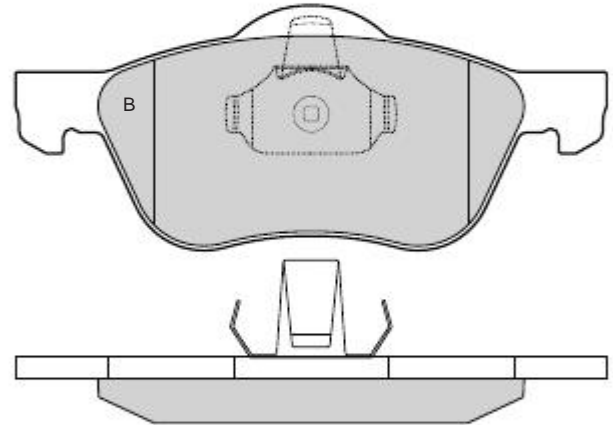
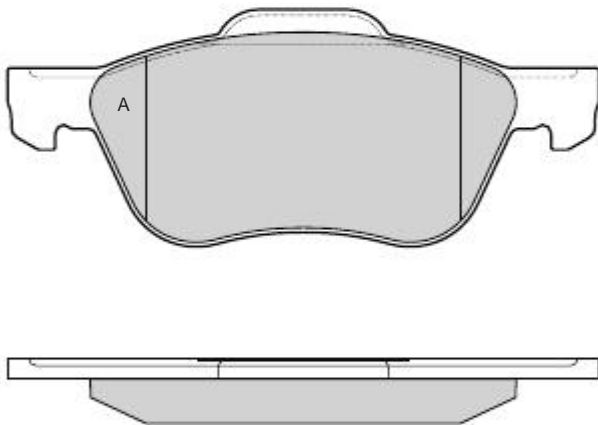



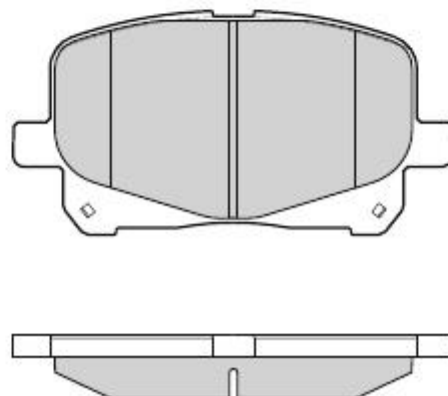



1048	NISSAN	ATE	X	156,2	A 62,7 B 64,8	17,3	2A-2B		
-------------	--------	-----	---	-------	------------------	------	-------	--	--



1049	TOYOTA	AKEBONO	X	116,5	59,4	17	4		
-------------	--------	---------	---	-------	------	----	---	--	--



									
1050	TOYOTA	AKEBONO	X	78,4	54	14	2A 1B-1C		

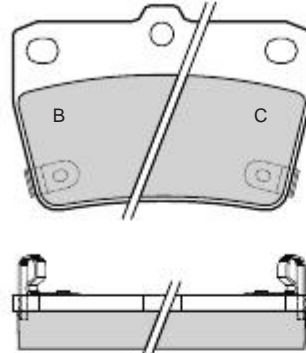
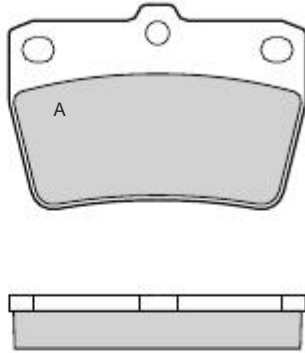



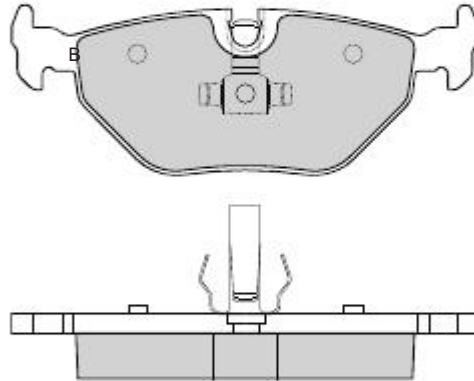
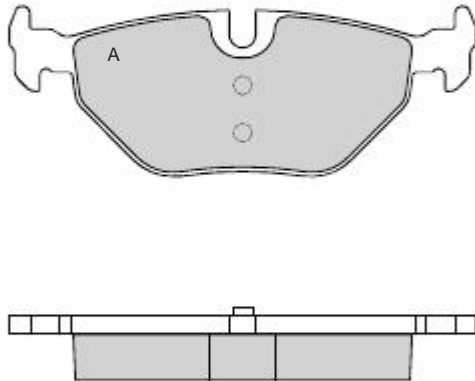



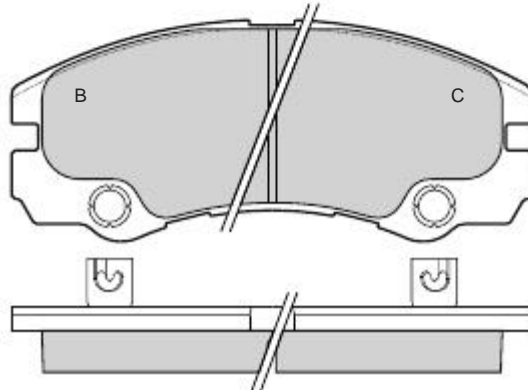
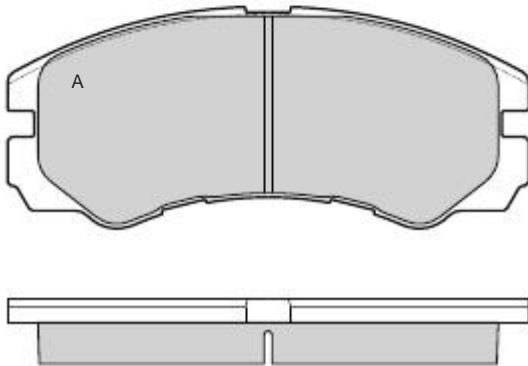

1051	BMW - ROVER	ATE	X	123,1	45	17	2A-2B		
------	-------------	-----	---	-------	----	----	-------	--	--



1052	OPEL - VAUXHALL	SUMITOMO	X	137,6	58,5	17	2A 1B-1C		
------	-----------------	----------	---	-------	------	----	-------------	--	--

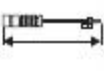

									
1053	TOYOTA	AKEBONO	X	131,7	52,3	17,8	2A 1B-1C		

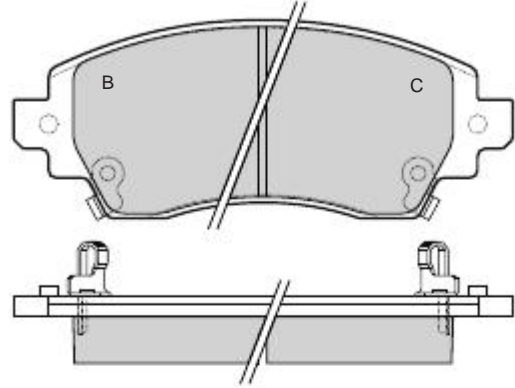
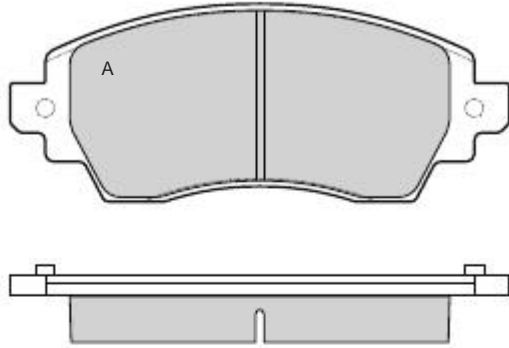



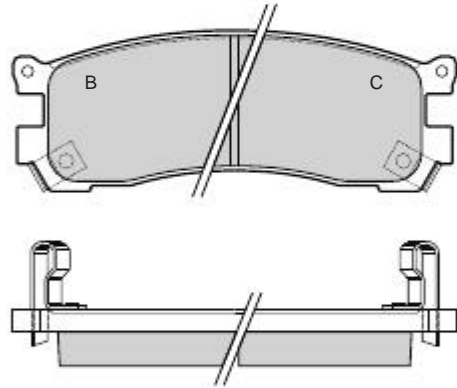
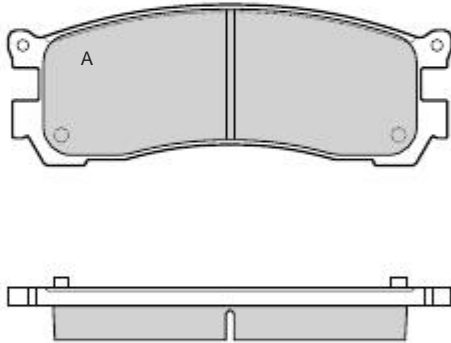



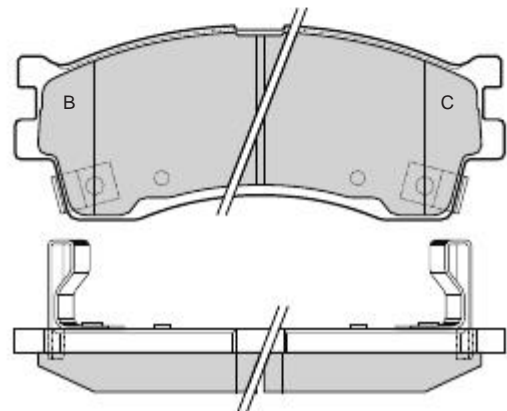
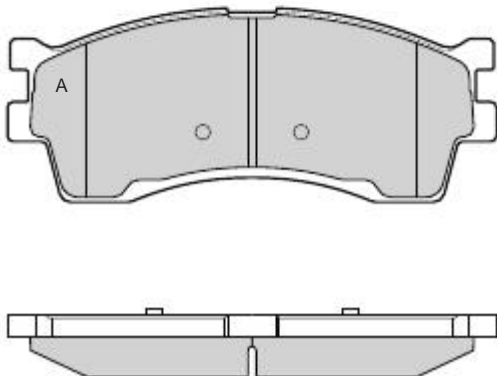

1054	MAZDA	AKEBONO	X	117	42,5	A 14 B-C 15	2A 1B-1C		
-------------	-------	---------	---	-----	------	----------------	-------------	--	--



1055	KIA	SUMITOMO	X	129,2	51,5	16,5	2A 1B-1C		
-------------	-----	----------	---	-------	------	------	-------------	--	--

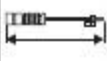

									
1056	SUBARU	AKEBONO	X	108,4	41,5	14,5	4		

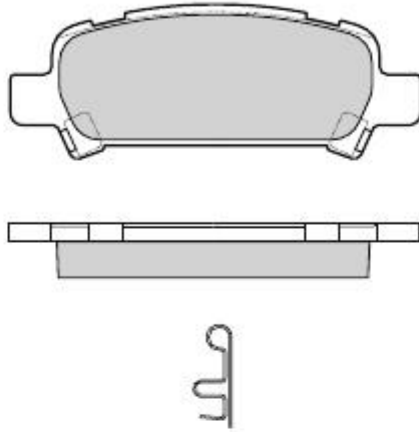



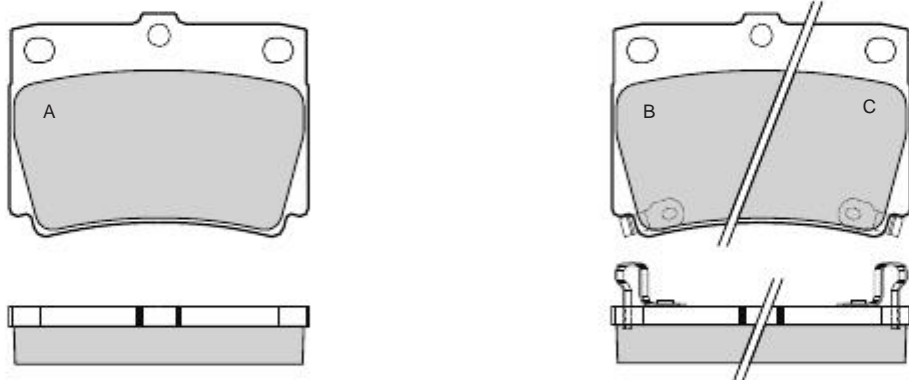



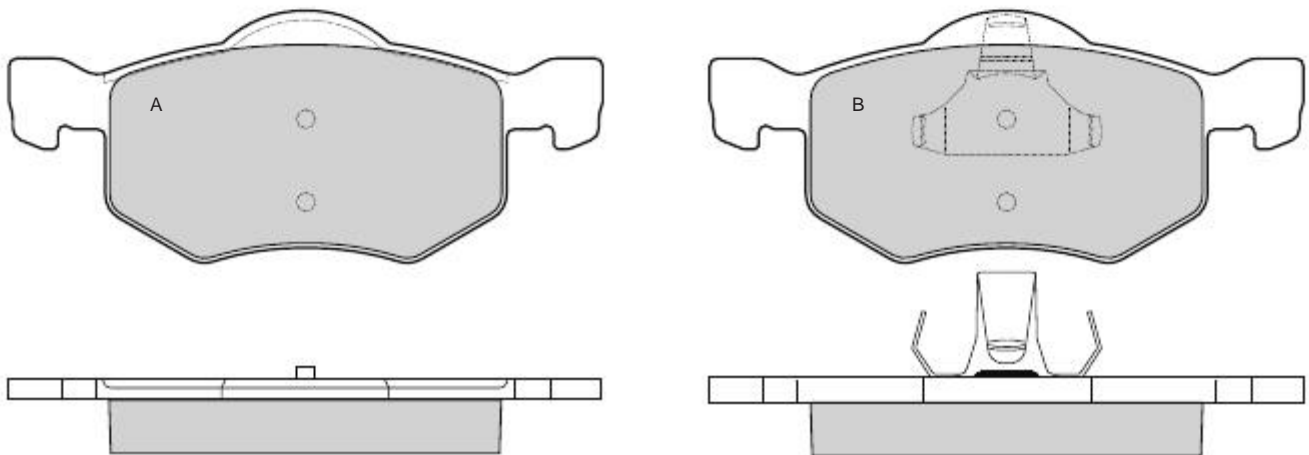

1057	MITSUBISHI	SUMITOMO	X	78,8	58,9	15	2A 1B-1C		
------	------------	----------	---	------	------	----	-------------	--	--



1058	FORD - MAZDA	ATE	X	156,7	66,6	A 19,6 B 20,6	2A-2B		
------	--------------	-----	---	-------	------	------------------	-------	--	--

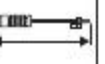

									
1059	HONDA	SUMITOMO	X	148,7	59,6	17	2A 1B-1C		

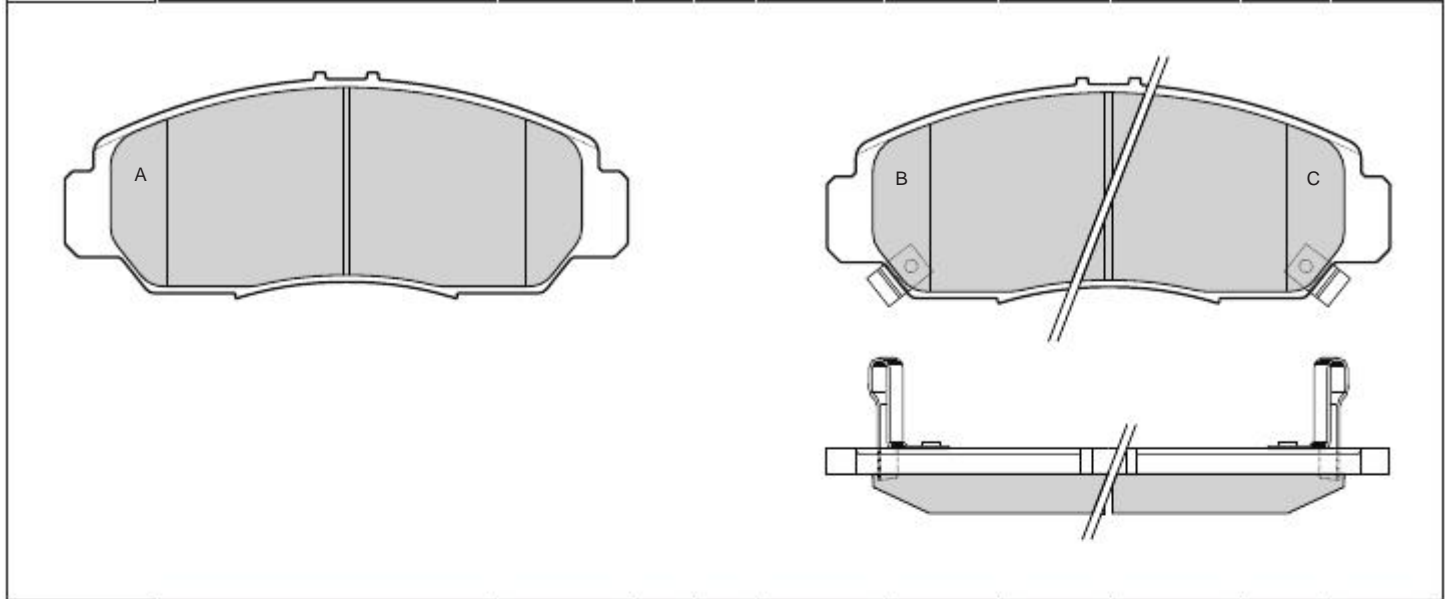



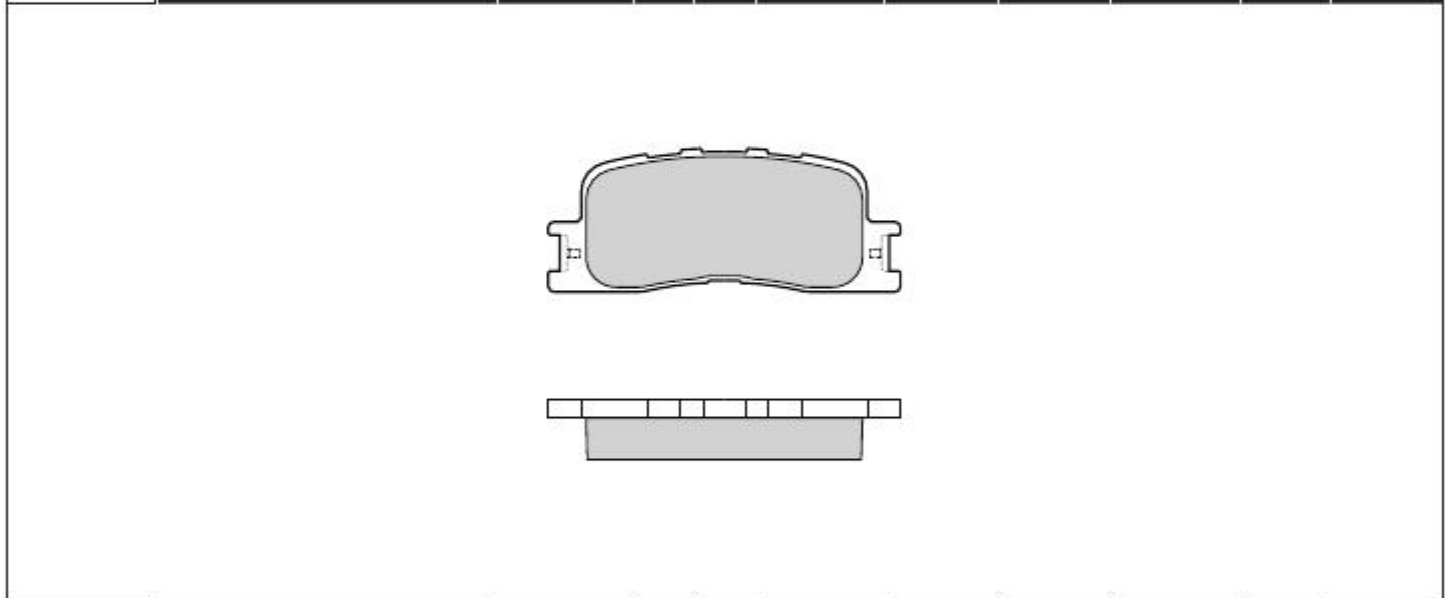



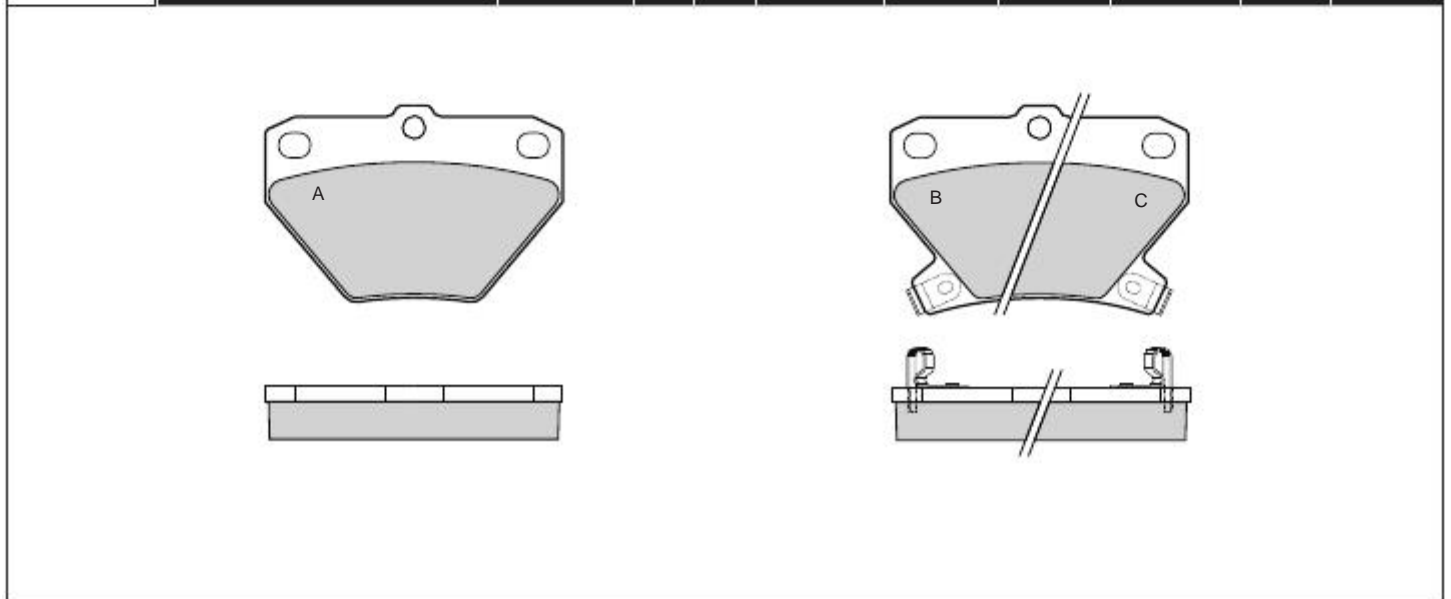



1060	TOYOTA	AKEBONO	X	93	38	16	4		
------	--------	---------	---	----	----	----	---	--	--



1061	TOYOTA	SUMITOMO	X	78,5	A 51,9 B-C 55,4	14	2A 1B-1C		
------	--------	----------	---	------	--------------------	----	-------------	--	--



									
1062	VOLVO	ATE	X	A 156,3 B 155,2	A 74,3 B 75,3	A 19,5 B 20,8	2A-2B		

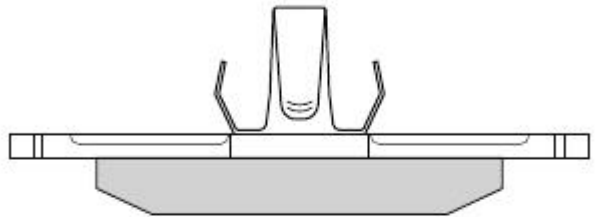
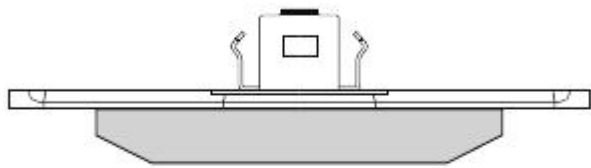
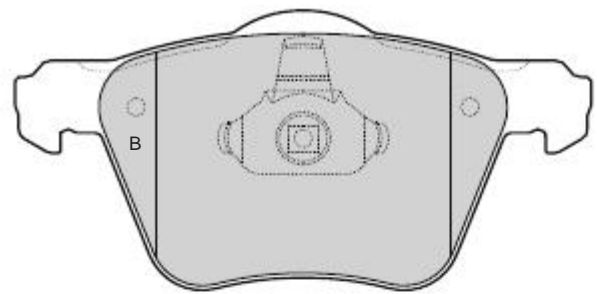
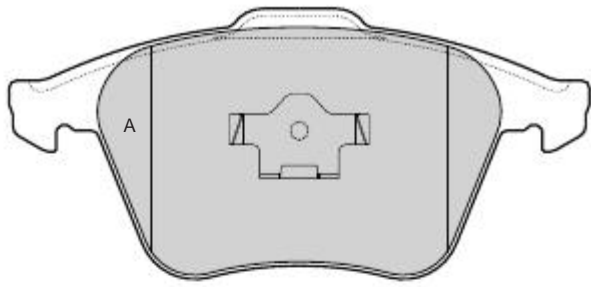







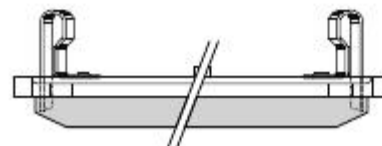
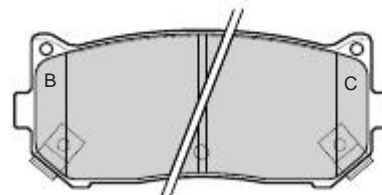
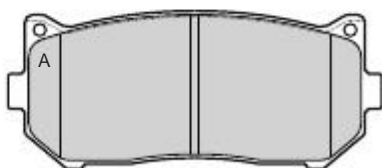

1063	TOYOTA	AKEBONO	X	83	38,5	15	4		
------	--------	---------	---	----	------	----	---	--	--



1064	KIA	SUMITOMO	X	98,7	41,6	13	2A 1B-1C		
------	-----	----------	---	------	------	----	-------------	--	--

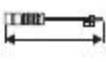

									
1065	DAIHATSU	AKEBONO	X	104,6	45	13,8	4		

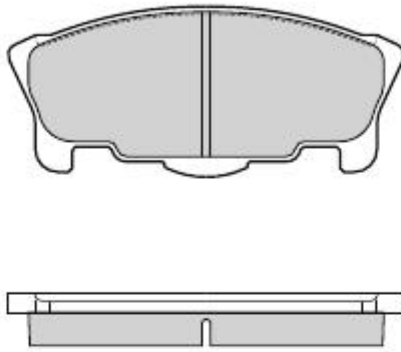



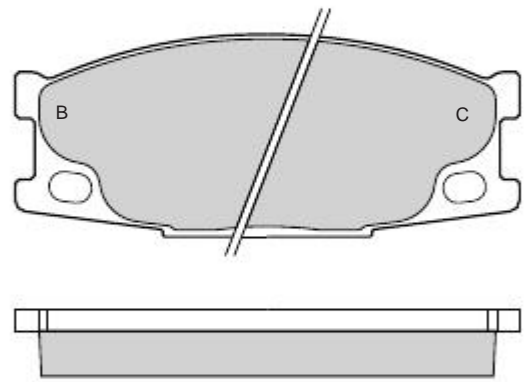
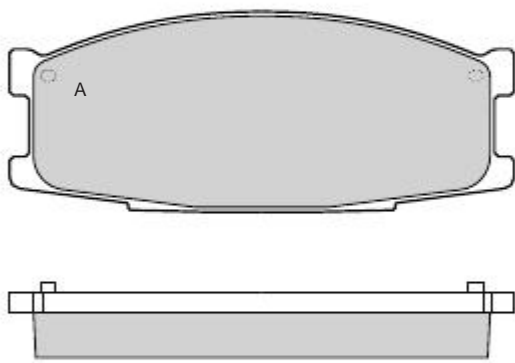



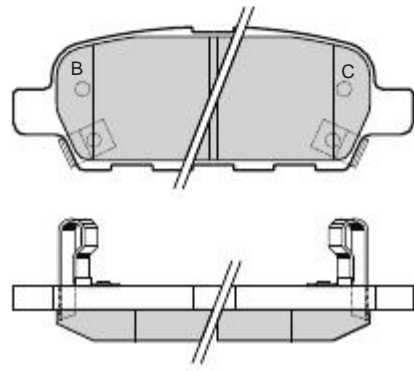
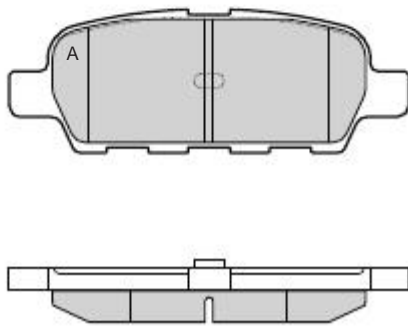



1066	MITSUBISHI	SUMITOMO	X	133,3	A 53 B-C 53,5	17,5	2A 1B-1C		
------	------------	----------	---	-------	------------------	------	-------------	--	--



1067	NISSAN	AKEBONO	X	105,5	38	14,3	2A 1B-1C		
------	--------	---------	---	-------	----	------	-------------	--	--



									
1068	NISSAN	SUMITOMO	X	159	56	16,4	2A 1B-1C		

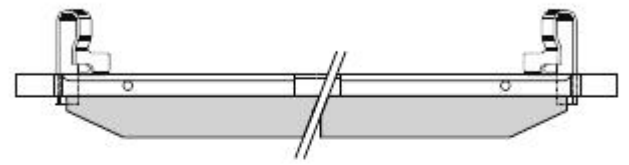
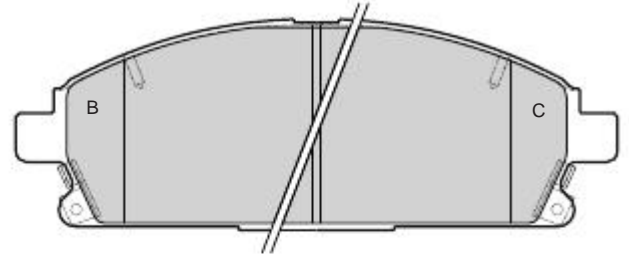
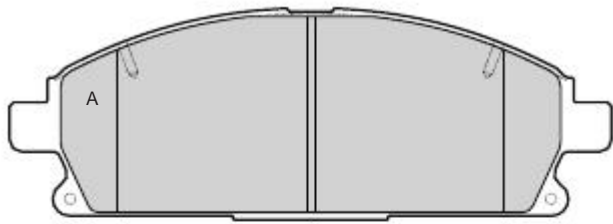



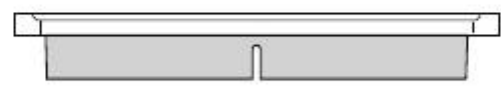
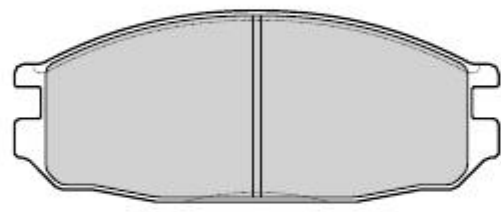



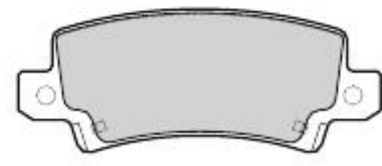

1069	NISSAN	SUMITOMO	X	127,8	50,5	17	4		
------	--------	----------	---	-------	------	----	---	--	--



1070	TOYOTA	LUCAS	X	95,7	37,9	16,3	4		
------	--------	-------	---	------	------	------	---	--	--

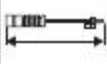

									
1071	AUDI - SKODA VOLKSWAGEN	ATE		156,4	74,2	20	2A 1B-1C	2	210

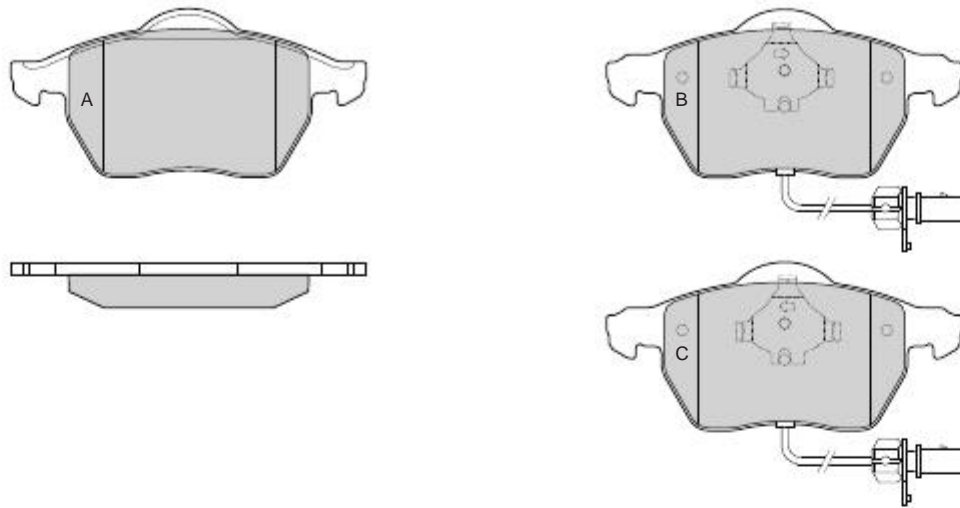





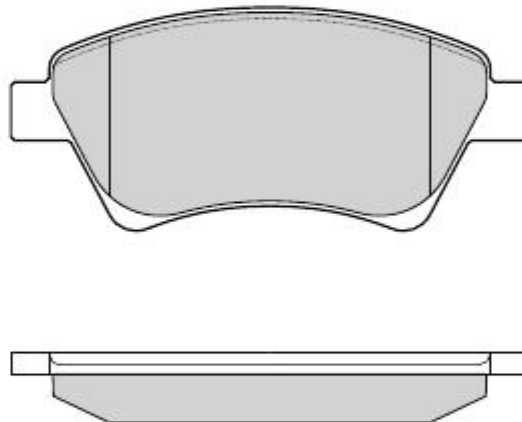



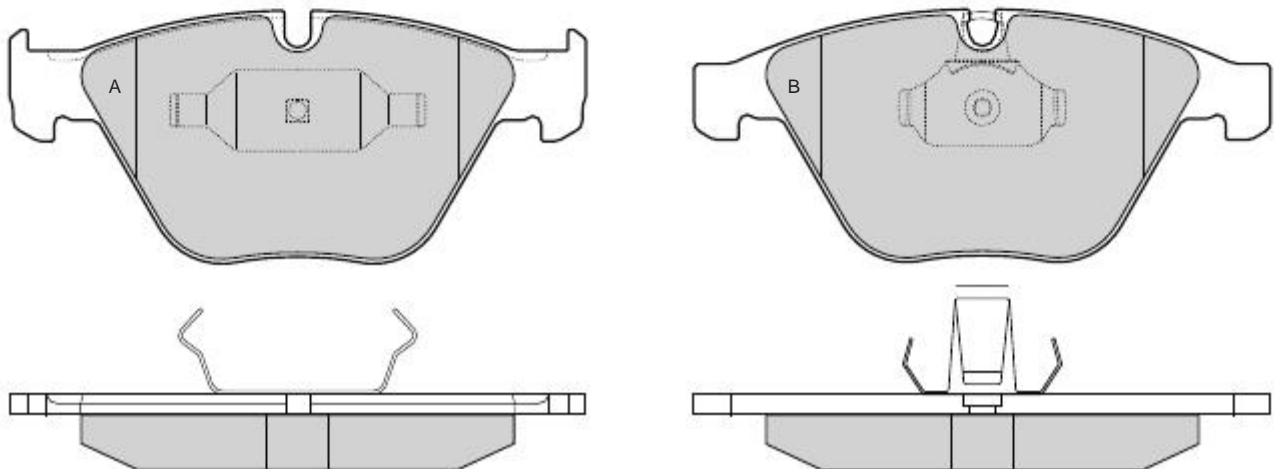

30%

1072	RENAULT	BOSCH	X	136,8	59,1	18,3	4		
------	---------	-------	---	-------	------	------	---	--	--



1073	BMW	ATE	X	155,1	68,5	20,3	2A-2B		
------	-----	-----	---	-------	------	------	-------	--	--

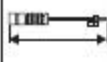

									
1074	NISSAN - OPEL - RENAULT VAUXHALL	BOSCH	X	115,8	51,3	16,8	4		

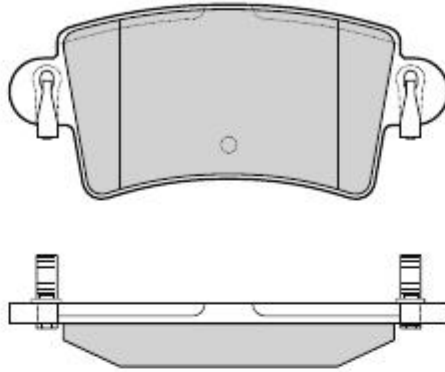



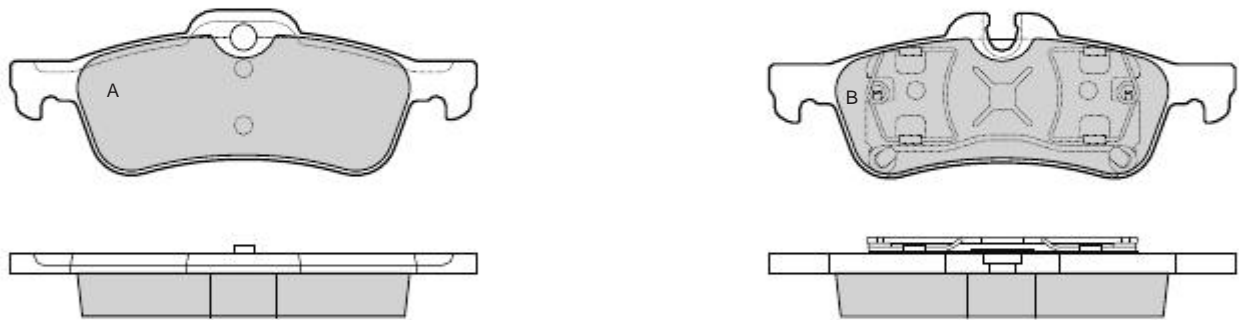



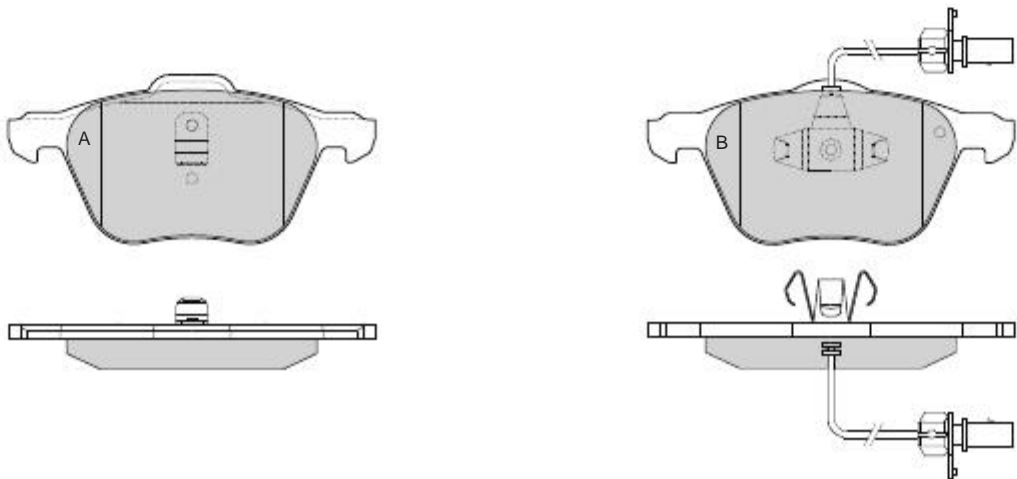

1075	MINI (BMW)	ATE	X	123,1	43,7	16,5	2A-2B		
-------------	------------	-----	---	-------	------	------	-------	--	--



1076	FORD - SEAT VOLKSWAGEN	ATE	X	161,4	A 74,6 B 72,8	20,1	2A-2B	2	285
-------------	---------------------------	-----	---	-------	------------------	------	-------	---	-----

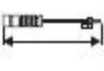

30%

									
1077	HONDA	AKEBONO	X	135,3	52,5	17	2A 1B-1C		

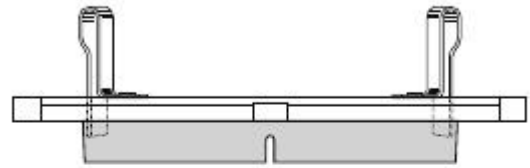
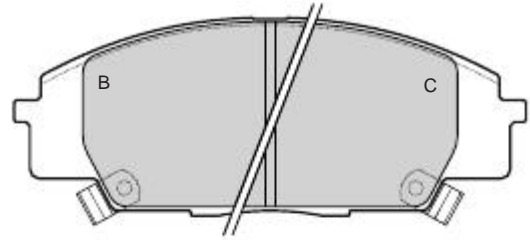
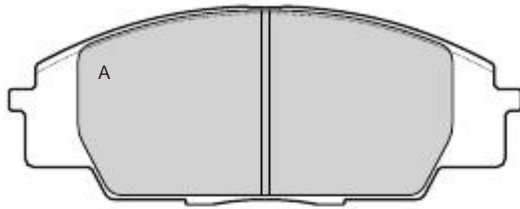



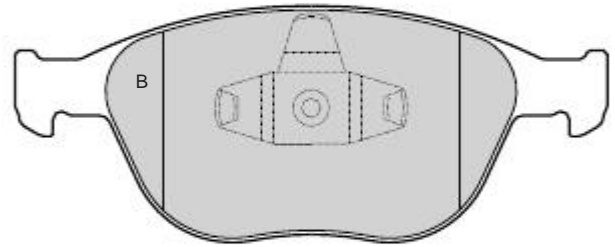



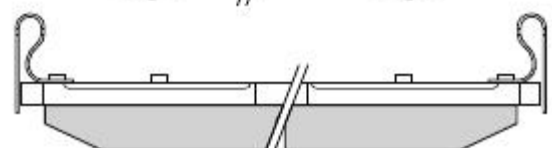
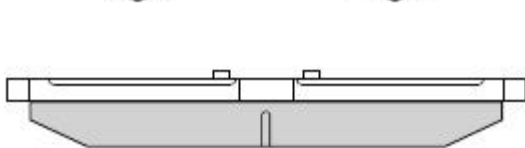
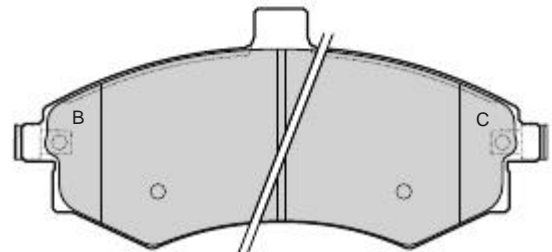
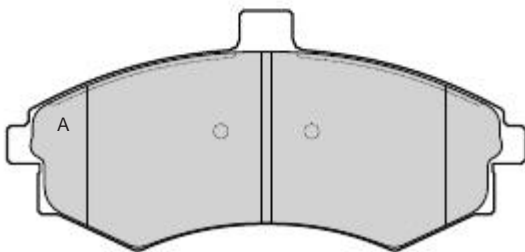

1078	FORD	ATE	X	156,3	A 67,7 B 62,5	17,8	2A-2B		
------	------	-----	---	-------	------------------	------	-------	--	--



1079	HYUNDAI	MANDO	X	137	63,6	17,8	2A 1B-1C		
------	---------	-------	---	-----	------	------	-------------	--	--

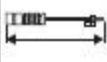

									
1080	CHRYSLER - DODGE MITSUBISHI	AKEBONO	X	144,8	55	16	4		

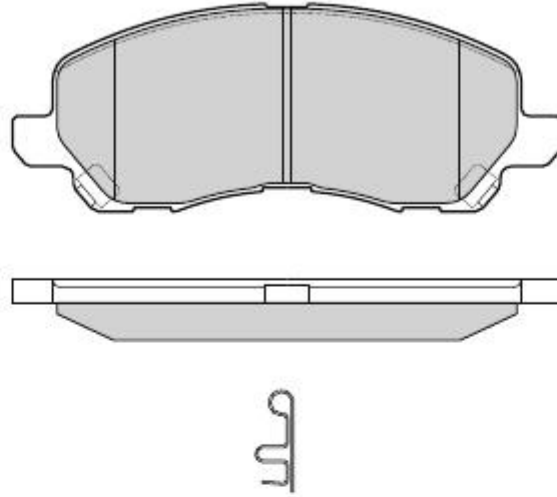



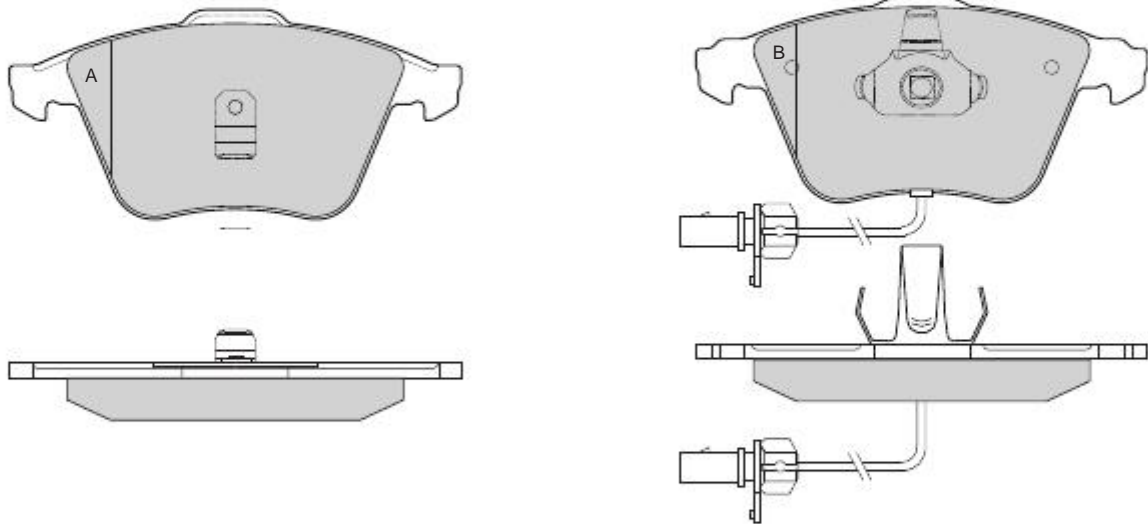



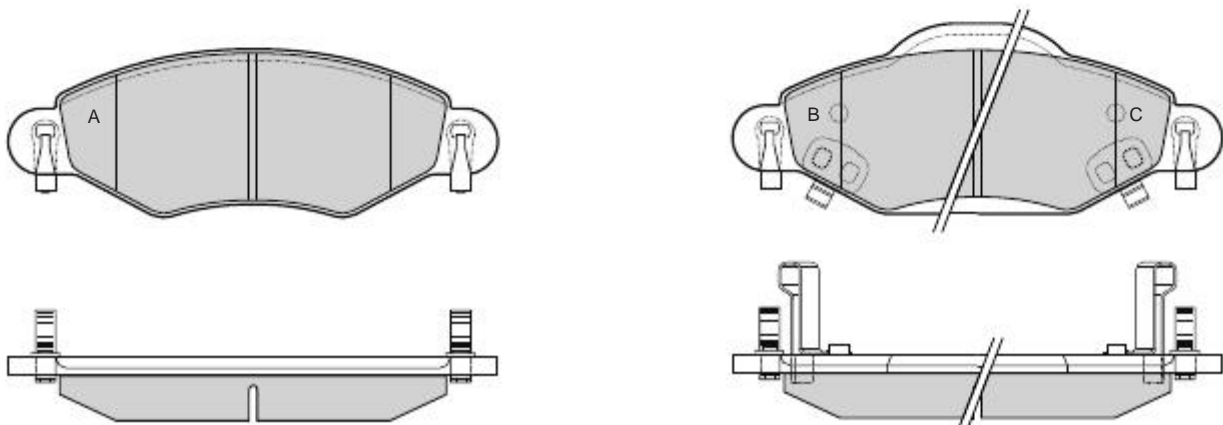



1081	AUDI	ATE	X	A 156,2 B 155	72,9	20	2A-2B	2	280
-------------	------	-----	---	------------------	------	----	-------	---	-----



1082	TOYOTA	BOSCH	X	130,9	A 45 B 51	17	2A 1B-1C		
-------------	--------	-------	---	-------	--------------	----	-------------	--	--



									
1083	HONDA	SUMITOMO	X	148,7	58,5	18,5	2A 1B-1C		

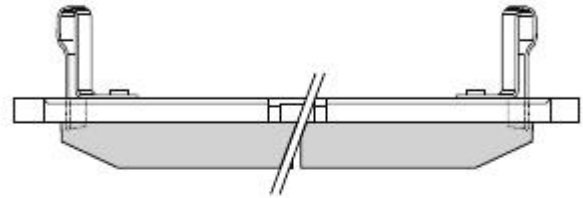
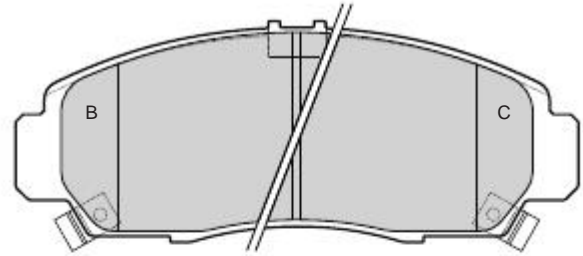
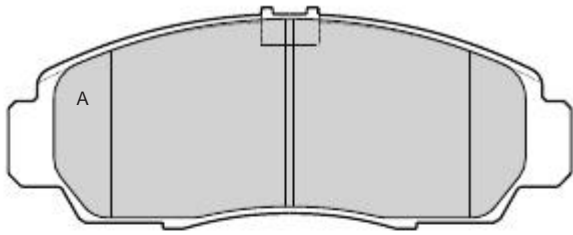



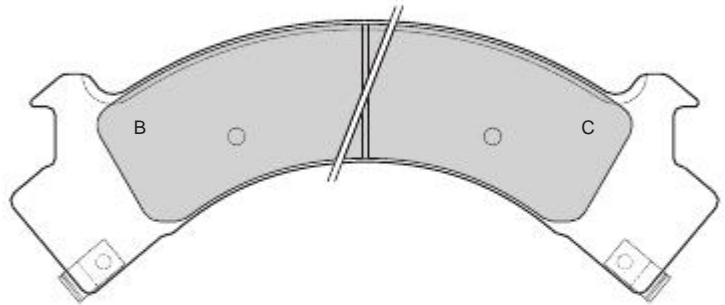
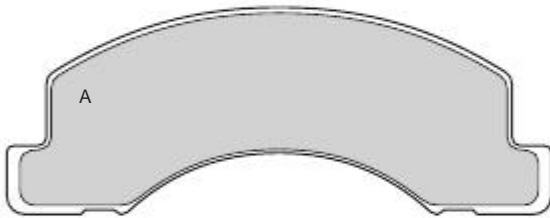



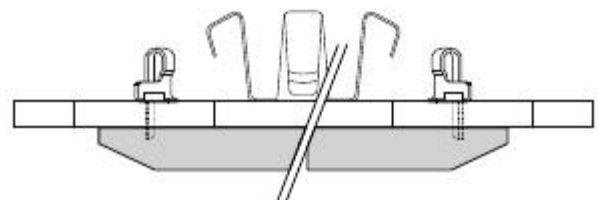
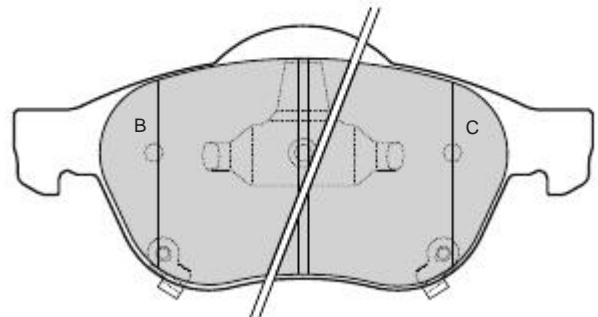



1084	ISUZU		X	A 183 B-C 237,5	A 69,6 B-C 93	A 22 B-C 22,5	2A 1B-1C		
-------------	-------	--	---	--------------------	------------------	------------------	-------------	--	--



1085	TOYOTA	ATE	X	A 156,2 B 155	A 68,4 B 70,8	18,2	2A 1B-1C		
-------------	--------	-----	---	------------------	------------------	------	-------------	--	--



									
1086	AUDI	GIRLING	X	116,2	58,6	17,5	4		

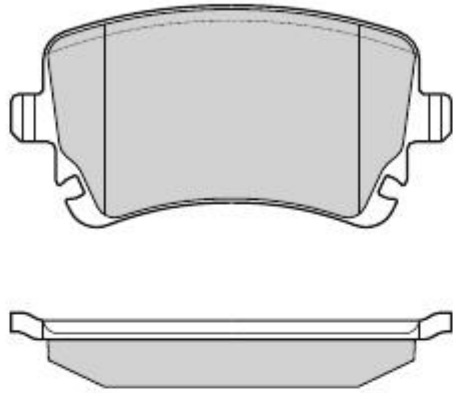



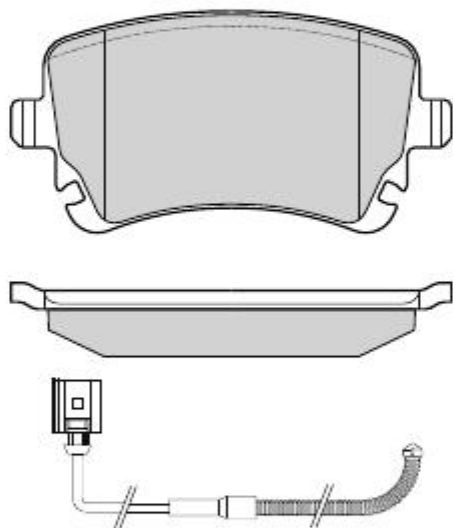



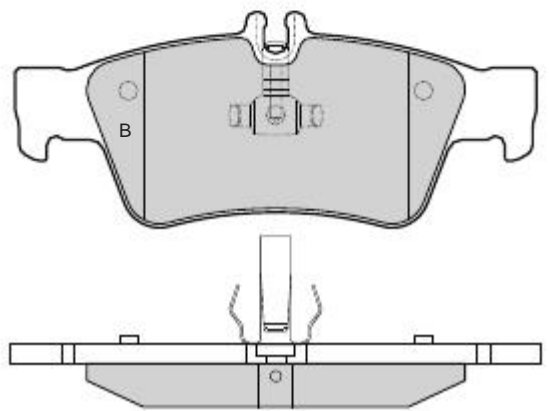
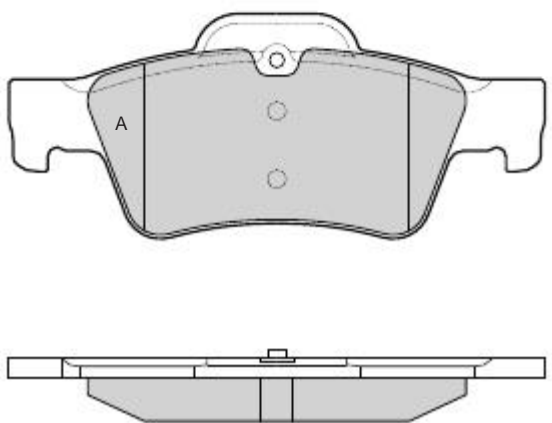

1087	AUDI - VOLKSWAGEN	GIRLING	X	116,2	58,6	17,5	4	2	635
------	-------------------	---------	---	-------	------	------	---	---	-----



1088	MERCEDES	ATE	X	A 141,5 B 140,5	A 59,5 B 57,4	16,5	2A-2B		
------	----------	-----	---	--------------------	------------------	------	-------	--	--

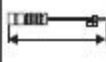

									
1089	MAZDA	SUMITOMO	X	131,8	59,4	18,8	2A 1B-1C		

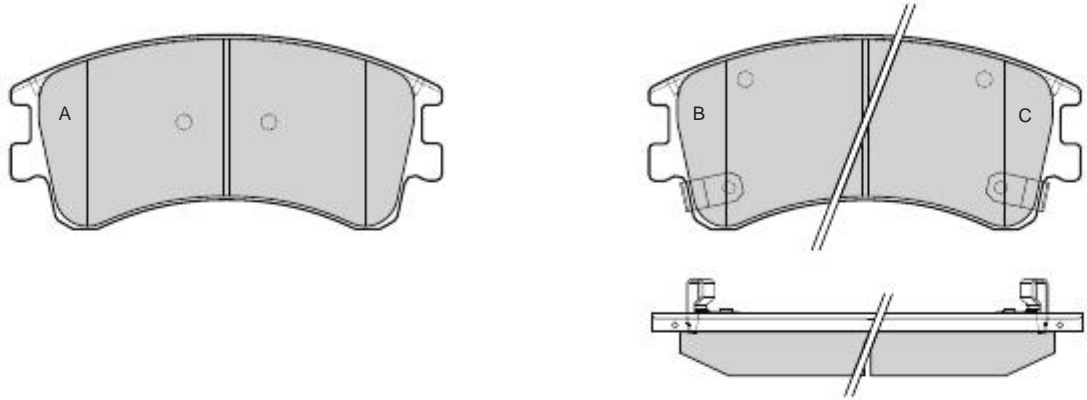



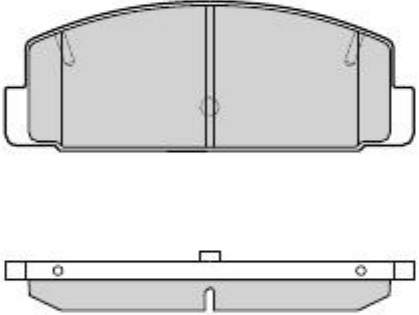



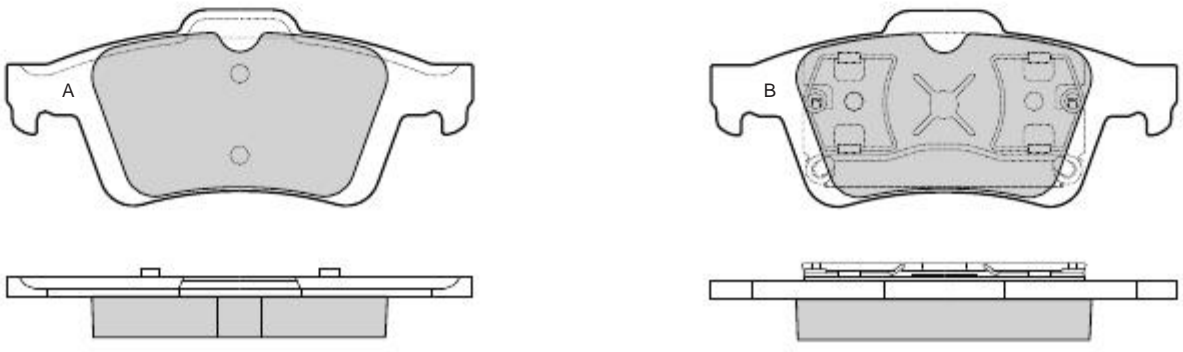

1090	MAZDA	AKEBONO	X	107,7	39,4	13	4		
------	-------	---------	---	-------	------	----	---	--	--



1091	MAZDA - SAAB	ATE	X	123	51,8	15,8	2A-2B		
------	--------------	-----	---	-----	------	------	-------	--	--

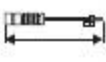

Reference in this Catalogue to other manufacturers and to part numbers and other descriptions are for identification purposes only, because the above **DISC BRAKE PADS** are **NOT ORIGINAL** but with these interchangeable

									
1092	MAZDA	SUMITOMO	X	131,2	56	17	2A 1B-1C		

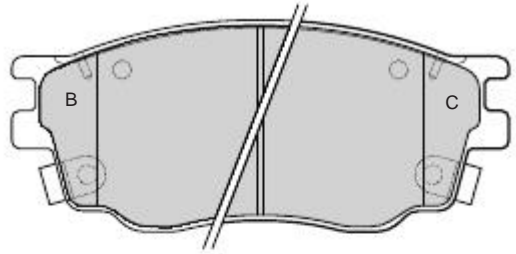
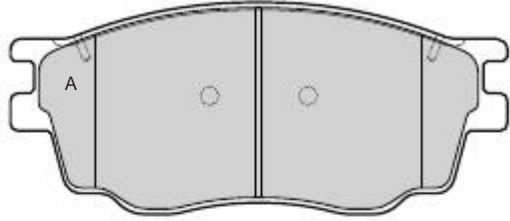



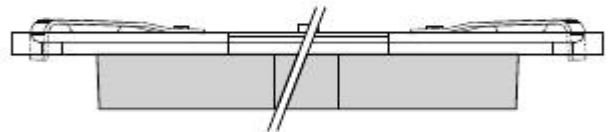
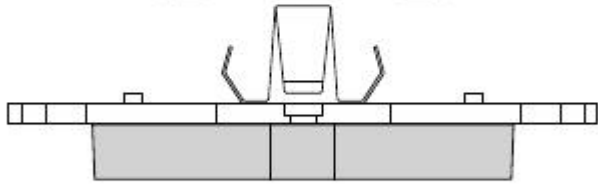
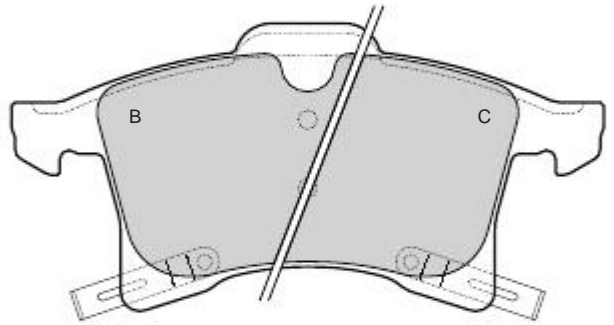
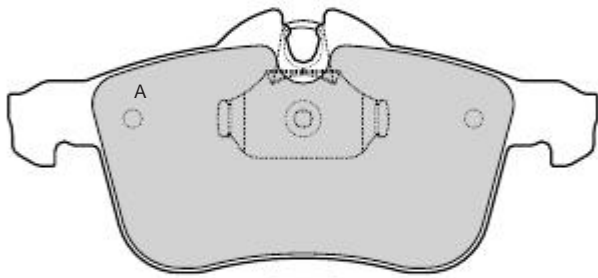



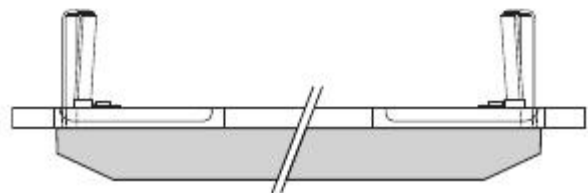
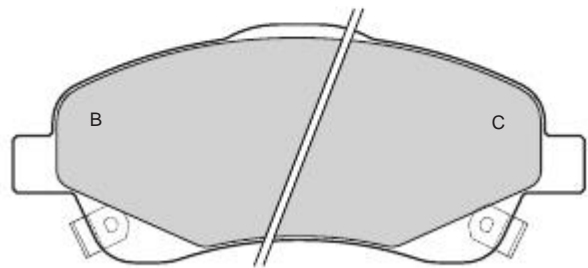
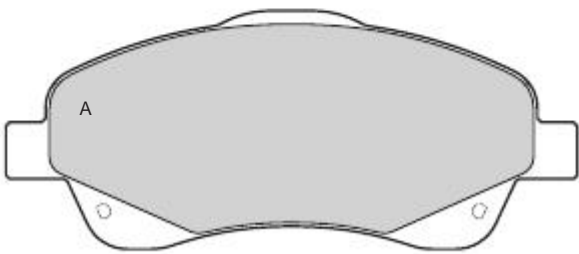

1093	OPEL - VAUXHALL	ATE	X	A 155,4 B-C 156,4	A 70,7 B-C 76	20	2A 1B-1C		
------	-----------------	-----	---	----------------------	------------------	----	-------------	--	--



1094	TOYOTA	BOSCH	X	151	63	19	2A 1B-1C		
------	--------	-------	---	-----	----	----	-------------	--	--

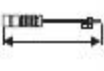

									
1095	BMW	ATE	X	193,2	79,2	20,8	2A-2B		

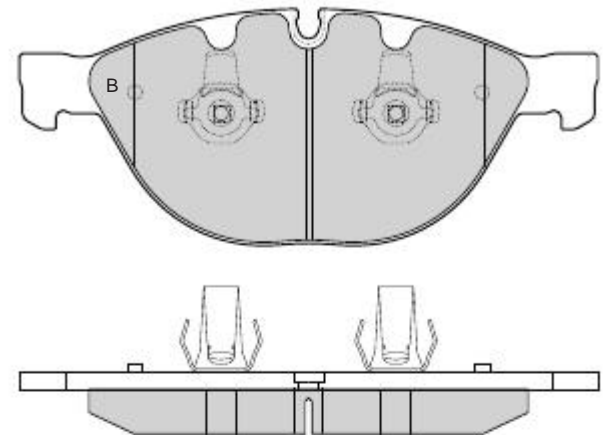
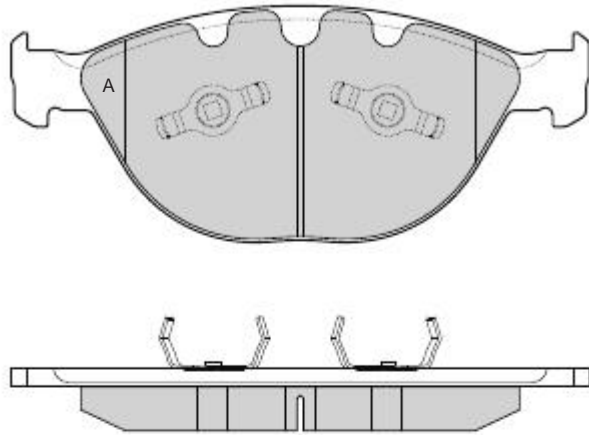



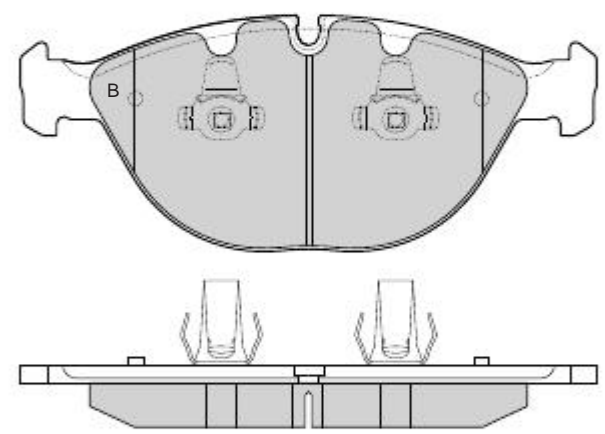
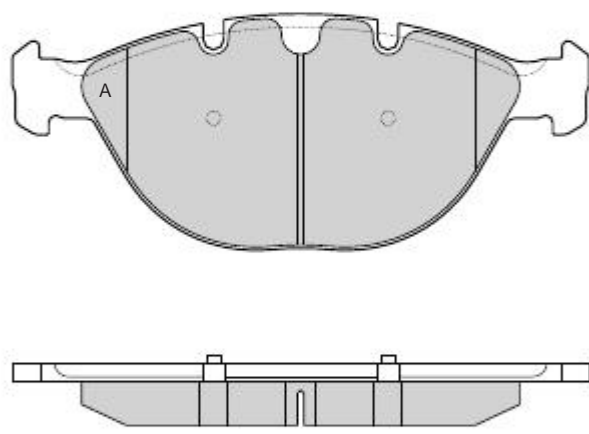



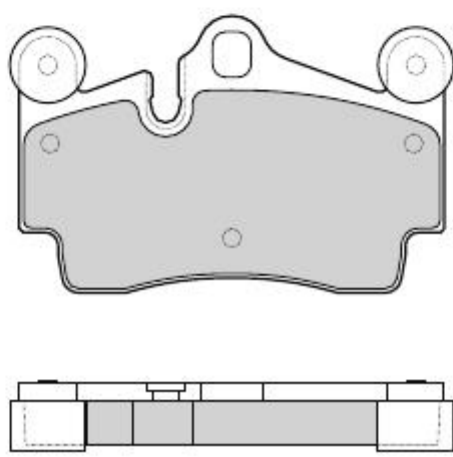



1096	BMW	ATE	X	193,2	79,2	20,8	2A-2B		
-------------	-----	-----	---	-------	------	------	-------	--	--



1097	PORSCHE - VOLKSWAGEN	BREMBO	X	112,2	73,2	16,2	4		
-------------	----------------------	--------	---	-------	------	------	---	--	--



									
1098	VOLKSWAGEN	BREMBO	X	190,2	99,5	16,6	4		

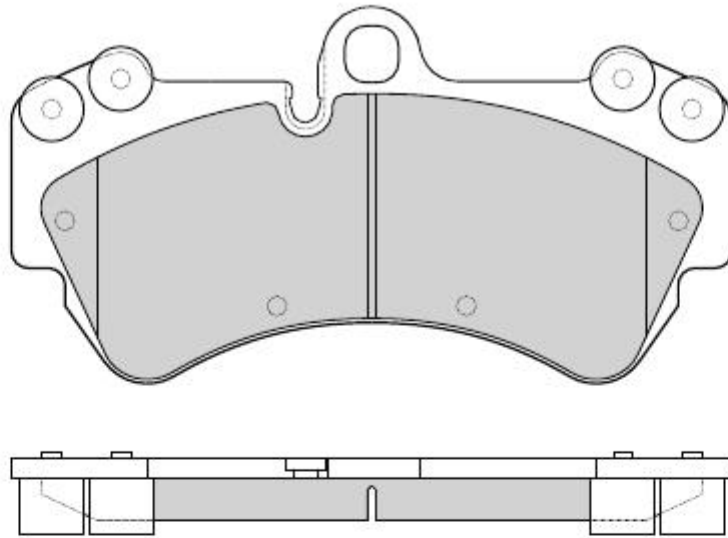



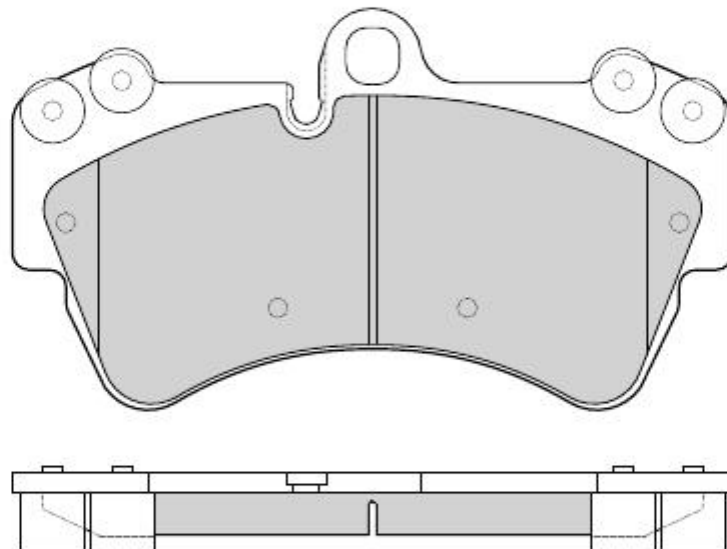



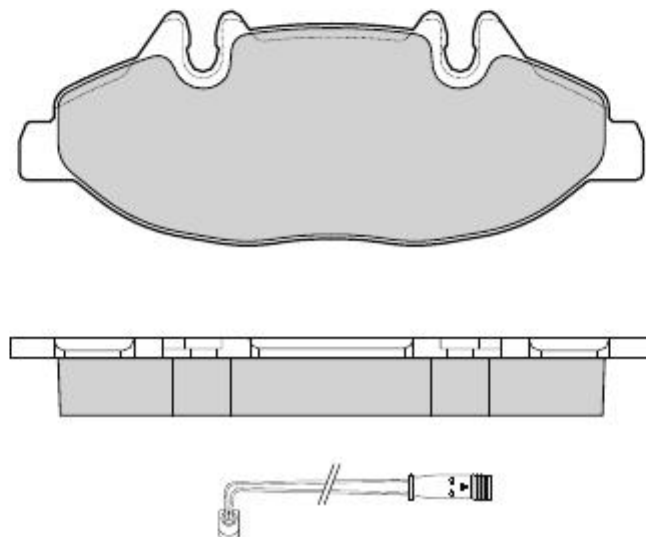

1099	PORSCHE - VOLKSWAGEN	BREMBO	X	190,2	106	16,6	4		
-------------	----------------------	--------	---	-------	-----	------	---	--	--



1100	MERCEDES	BOSCH	X	169,8	61,9	20,6	4	2	100
-------------	----------	-------	---	-------	------	------	---	---	-----

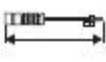

									
1101	MERCEDES	BOSCH	X	101,8	50,4	18,5	4	2	100

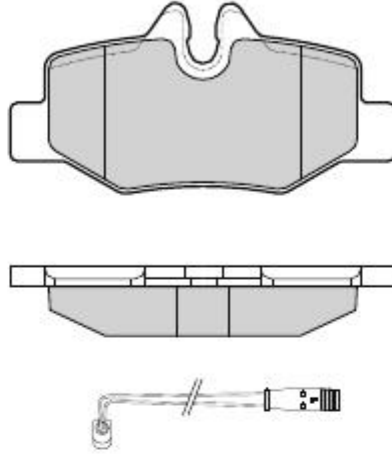



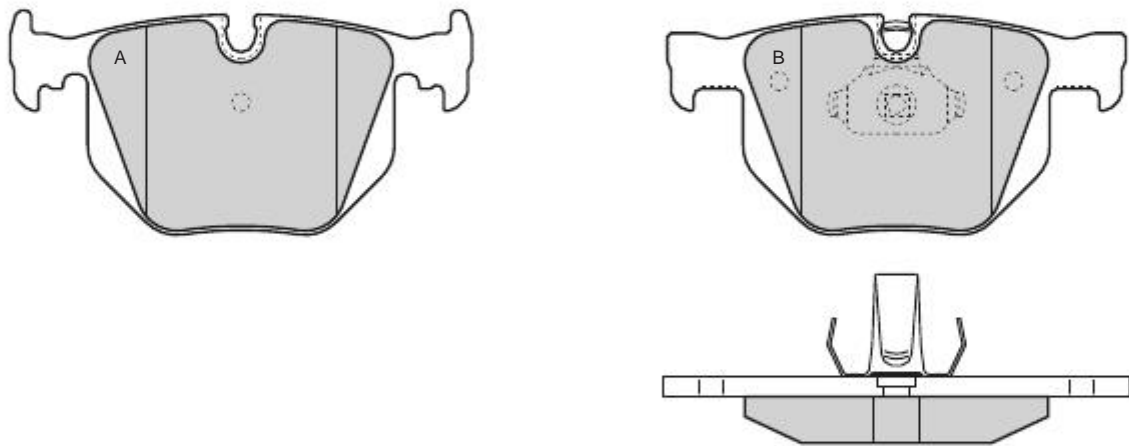



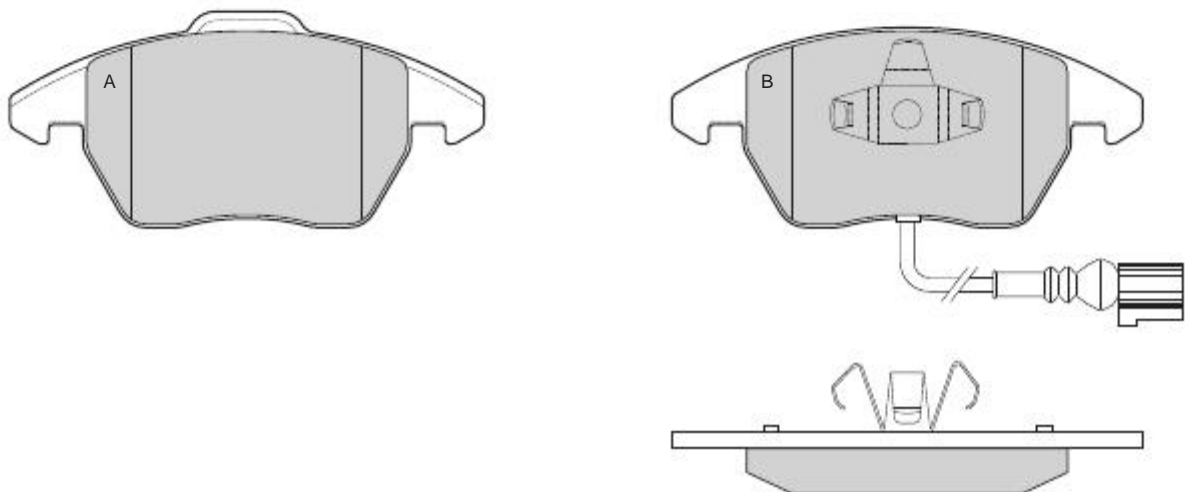



1102	BMW	ATE	X	A 123,1 B 122	A 59,2 B 58,2	17,3	2A-2B		
------	-----	-----	---	------------------	------------------	------	-------	--	--



1103	AUDI - VOLKSWAGEN	ATE	X	A 156,4 B 155,2	A 71,4 B 66	20,3	2A-2B	2	155
------	-------------------	-----	---	--------------------	----------------	------	-------	---	-----



									
1104	ROVER-MG	LOCKEED	X	113,6	59,2	16,1	4		

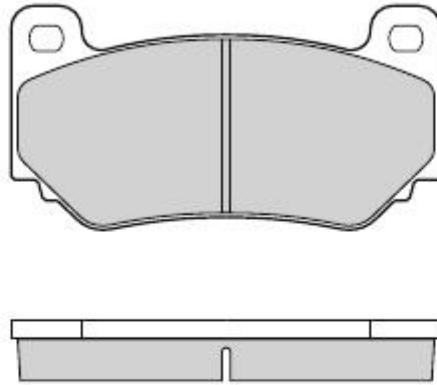



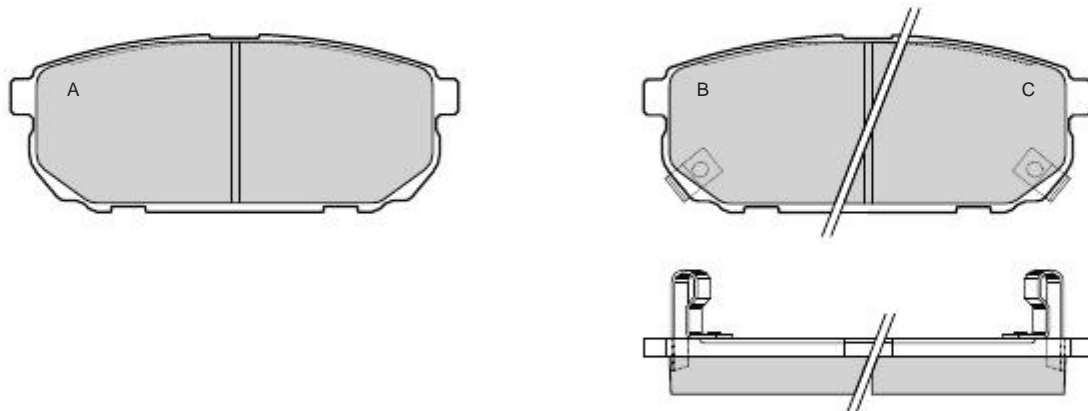



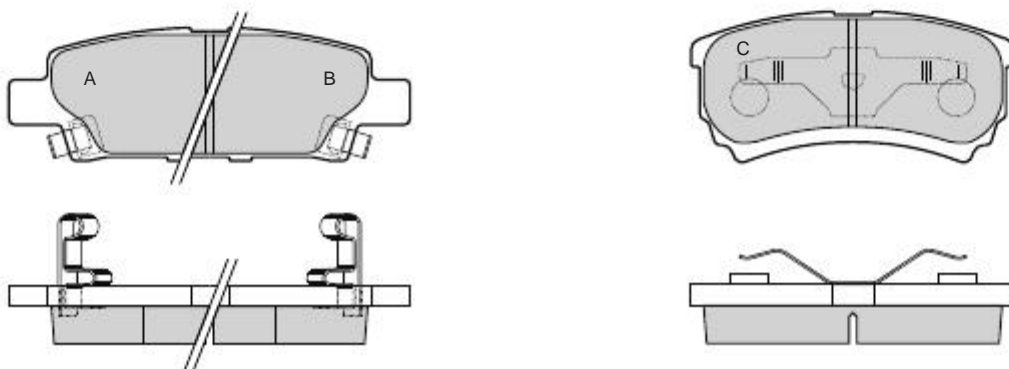

1105	KIA	SUMITOMO	X	118,2	47	14,8	2A 1B-1C		
-------------	-----	----------	---	-------	----	------	-------------	--	--



1106	MITSUBISHI	AKEBONO	X	A-B 105,9 C 85,5	A-B 35,3 C 39,9	15,5	1A 1B-2C		
-------------	------------	---------	---	---------------------	--------------------	------	-------------	--	--

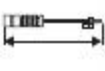

									
1107	TOYOTA	AKEBONO	X	87	46	16	2A-2B		

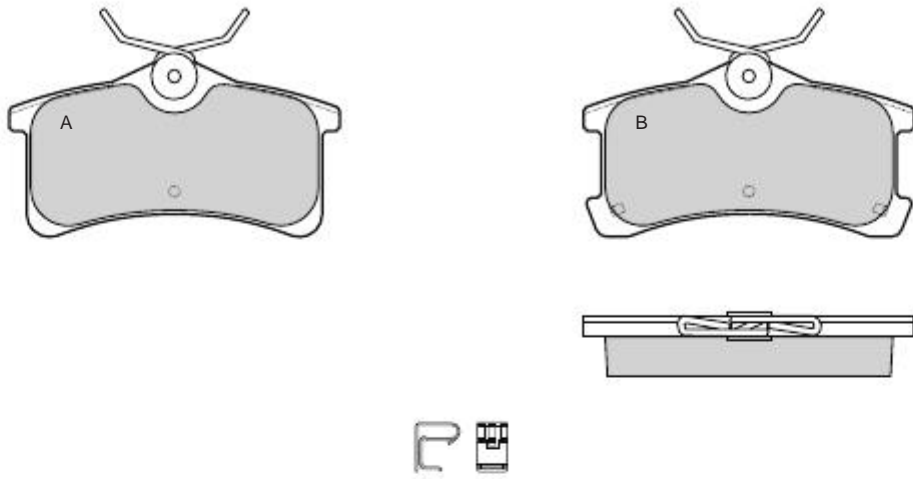



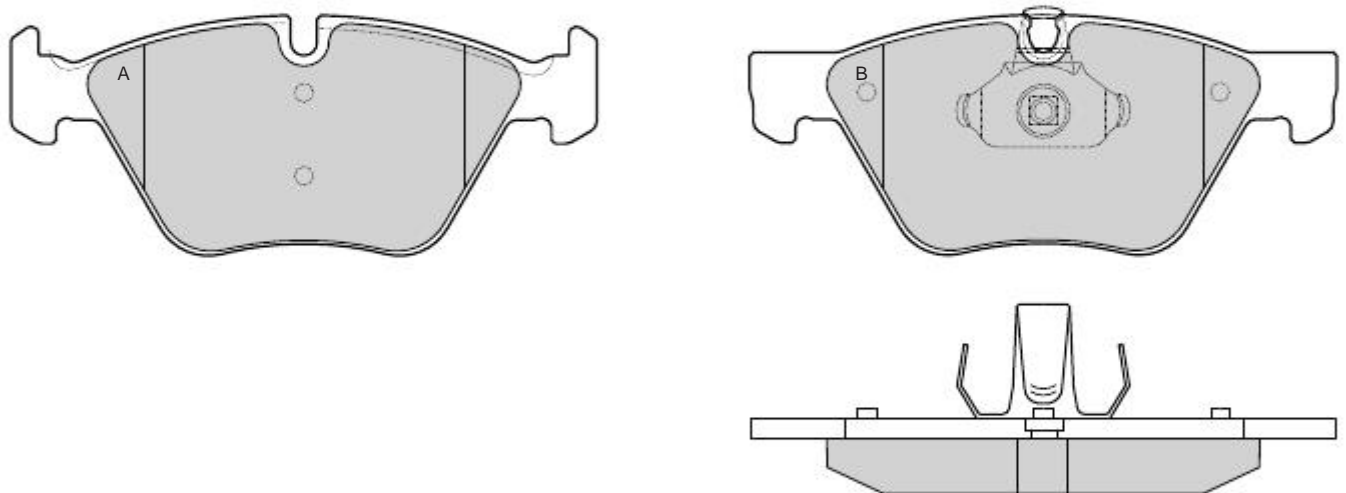



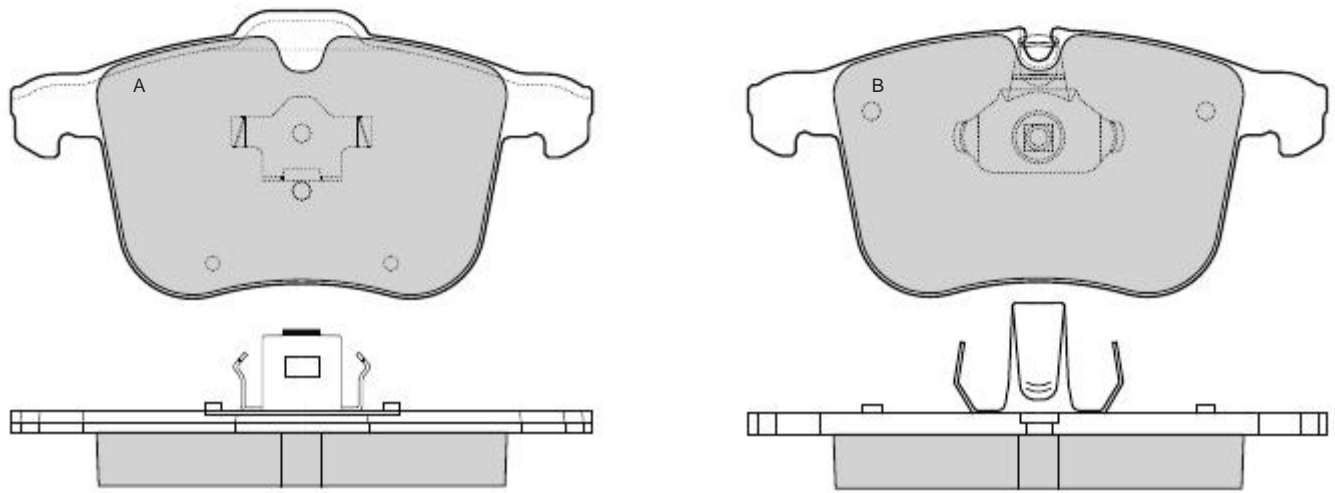



1108	BMW	ATE	X	A 154,8 B 155,2	63,6	20	2A-2B		
------	-----	-----	---	--------------------	------	----	-------	--	--



1109	OPEL - SAAB - VAUXHALL	ATE	X	A 156,4 B 155,2	A 77,5 B 73	20	2A-2B		
------	------------------------	-----	---	--------------------	----------------	----	-------	--	--



									
1110	VOLVO	ATE	X	123,1	A 61,8 B 63,6	19	2A-2B		

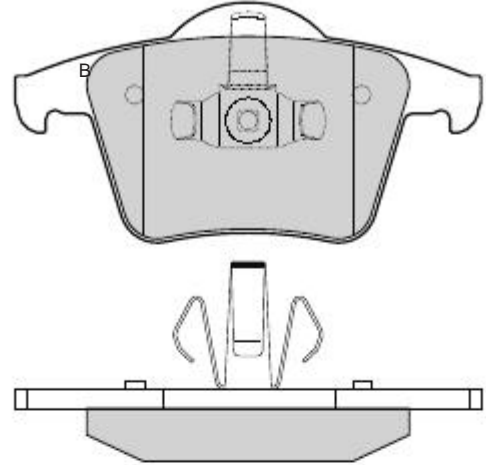



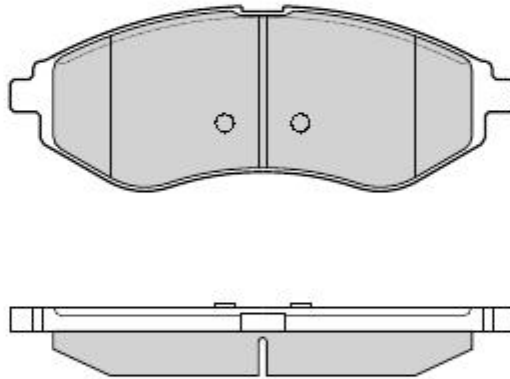



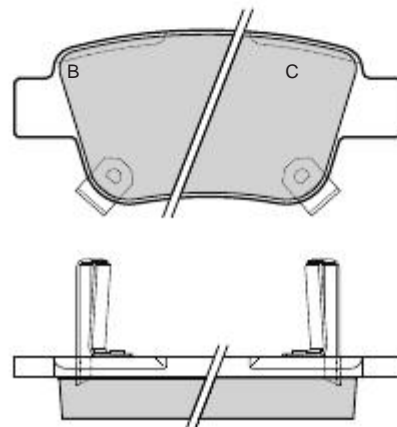

1111	DAEWOO	AKEBONO	X	133,2	48,8	17,8	4		
-------------	--------	---------	---	-------	------	------	---	--	--



1112	TOYOTA	BOSCH	X	102	45,9	16,3	2A 1B-1C		
-------------	--------	-------	---	-----	------	------	-------------	--	--

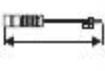

									
1113	RENAULT	LUCAS	X	122,9	54,3	18,3	4		

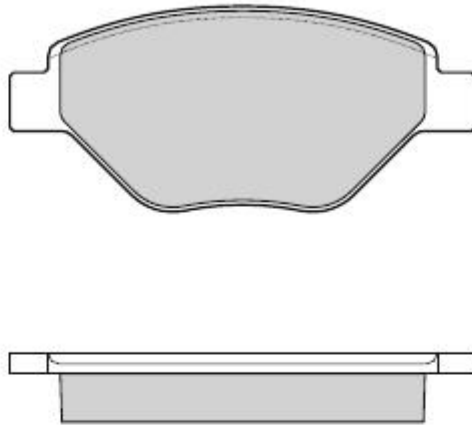



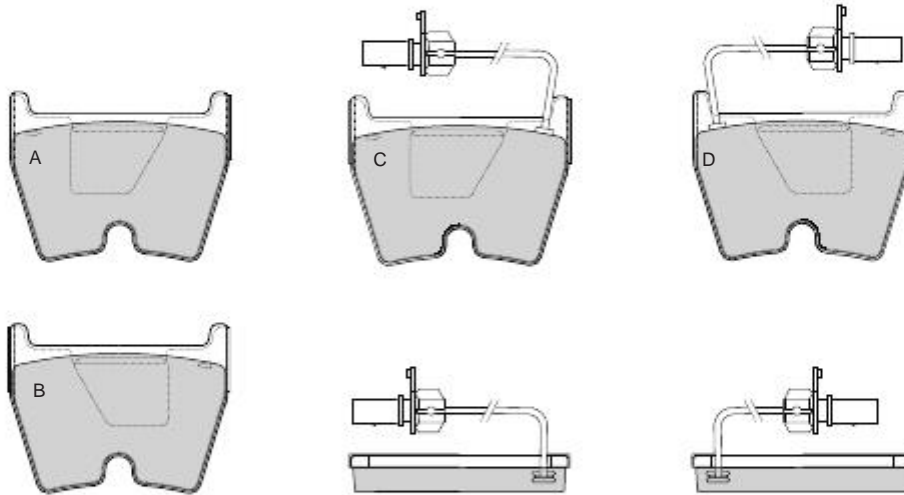





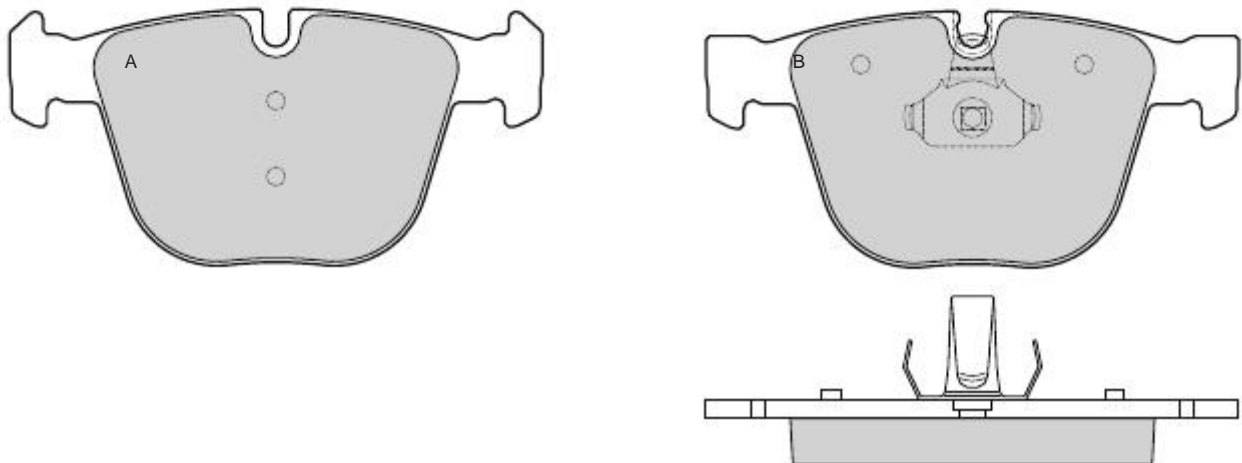

1114	AUDI - VOLKSWAGEN	BREMBO	X	97,1	74,4	16,5	3A-3B 1C-1D	2	280
------	-------------------	--------	---	------	------	------	----------------	---	-----



30%

1115	BMW	ATE	X	140,7	67,9	17,2	2A-2B		
------	-----	-----	---	-------	------	------	-------	--	--

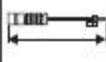

									
1116	KIA	SUMITOMO	X	155	60	17	2A 1B-1C		

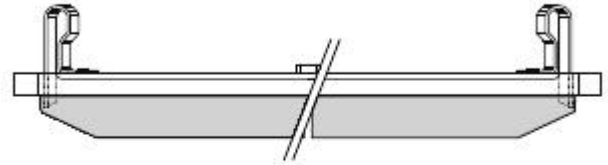
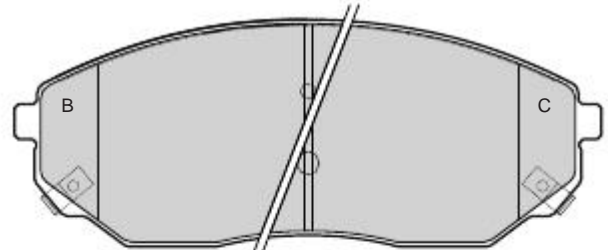
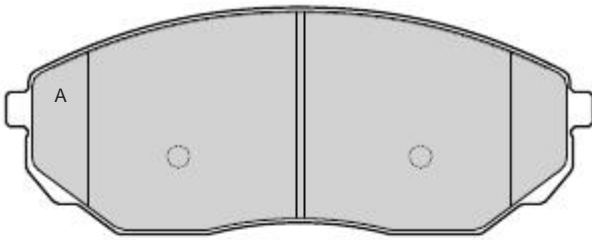



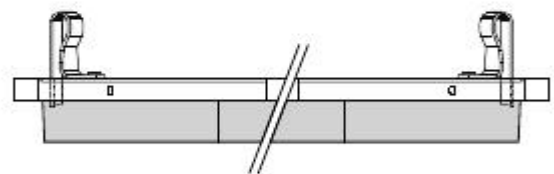
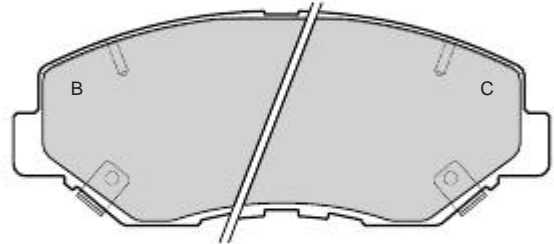
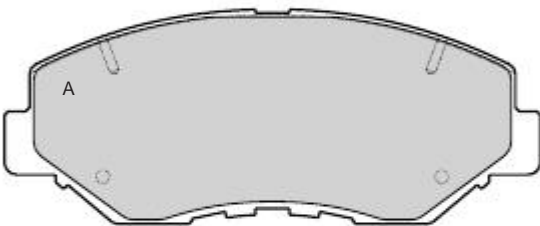



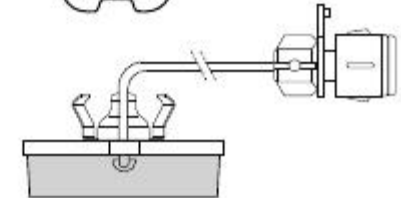
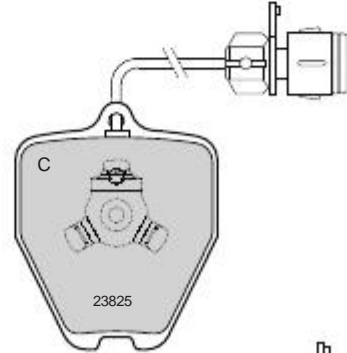
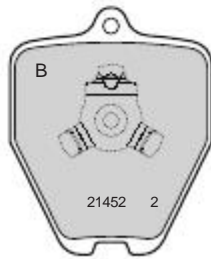
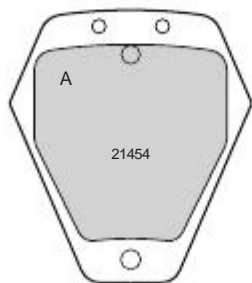











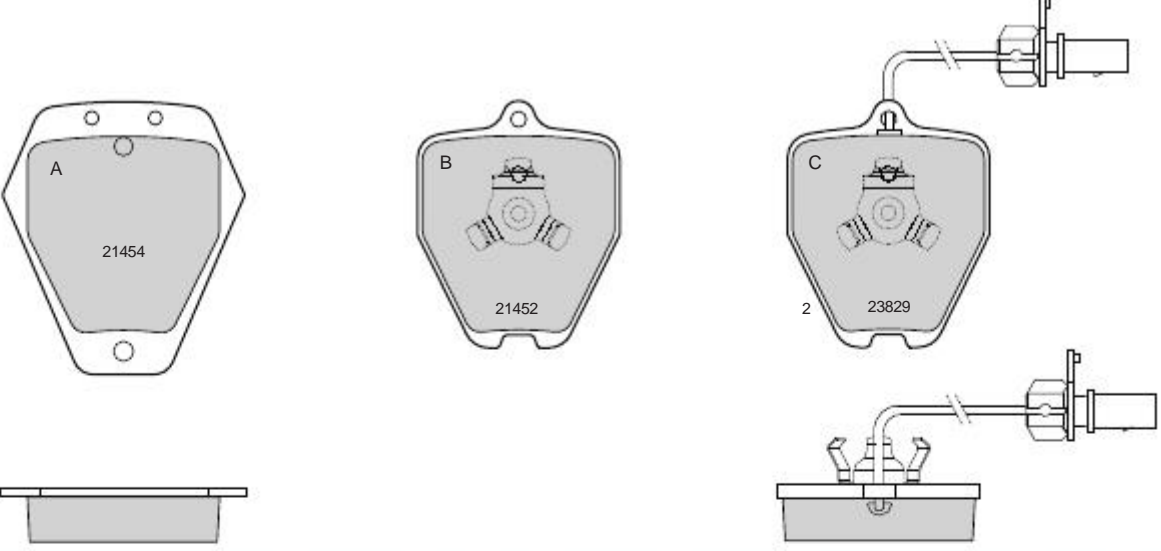
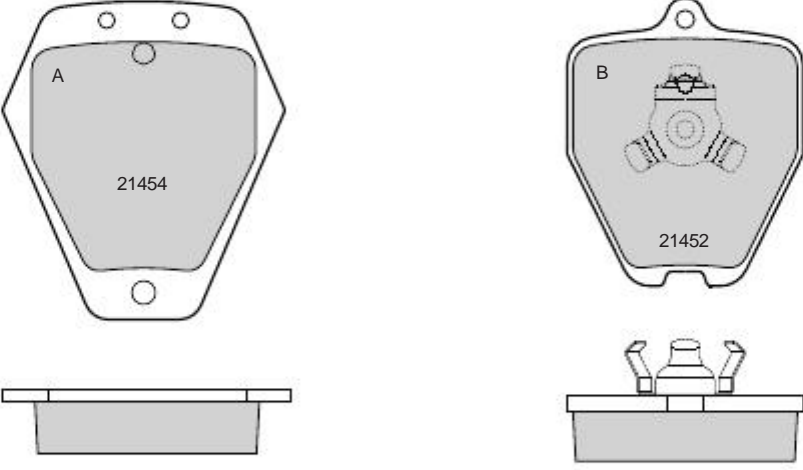
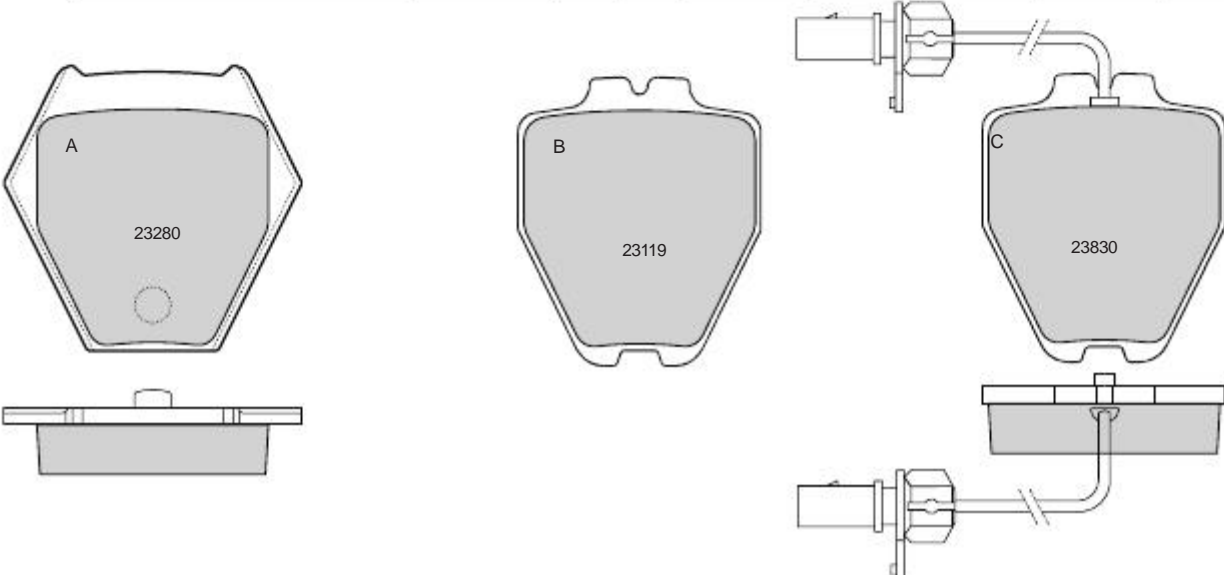

1117	HONDA	AKEBONO	X	141,5	56,3	16,9	2A 1B-1C		
------	-------	---------	---	-------	------	------	-------------	--	--



1118	AUDI	GIRLING	X	A-B 77,8 C 63,5	A 85,7 B-C 77,7	18,5	4A 2B-2C	2	280
------	------	---------	---	--------------------	--------------------	------	-------------	---	-----



									
1119	AUDI	GIRLING	X	A 77,8 B-C 63,5	A 85,7 B-C 77,7	17	4A 2B-2C	2	285
									
1120	AUDI	GIRLING	X	A 76,1 B 63,5	A 85,7 B 77,7	A 17 B 18,5	4A-4B		
									
1121	AUDI	GIRLING	X	A 77,8 B-C 63,5	A 74,6 B-C 75,4	17,5	4A 2B-2C	2	285
									

									
1122	AUDI	GIRLING	X	A 77,8 B-C 63,5	A 74,6 B-C 75,4	17,5	4A 2B-2C	2	280

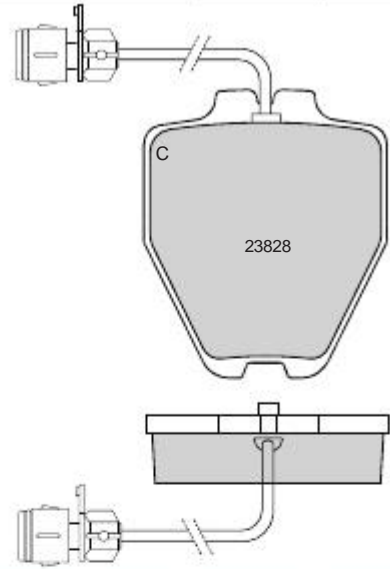
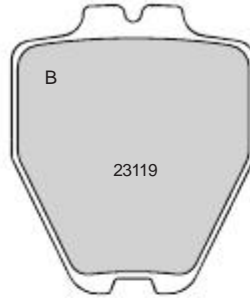
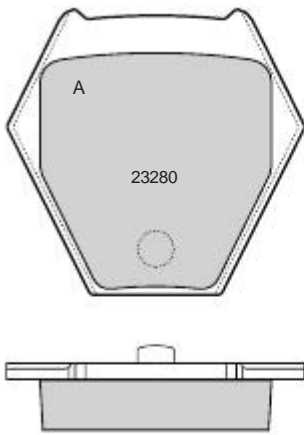



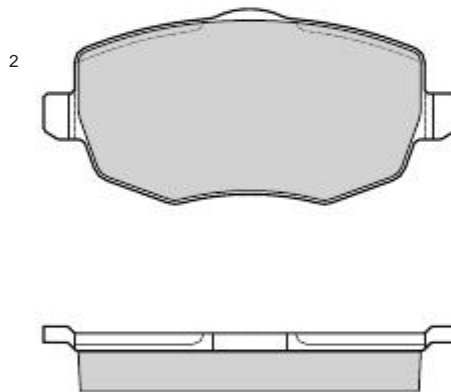



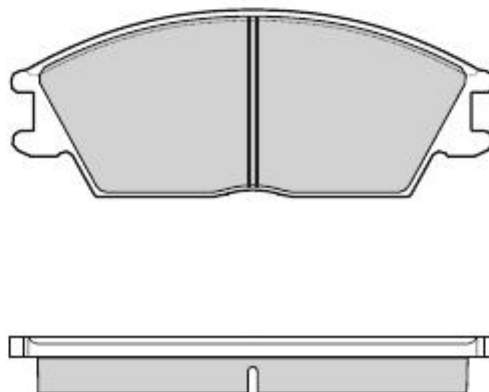



1123	LANCIA	LUCAS	X	116,5	55,2	16,5	4		
------	--------	-------	---	-------	------	------	---	--	--



1124	HONDA - HYUNDAI	AKEBONO	X	127,4	49	14,9	4		
------	-----------------	---------	---	-------	----	------	---	--	--



									
1125	NISSAN	AKEBONO	X	108,4	47,85	16,5	4		

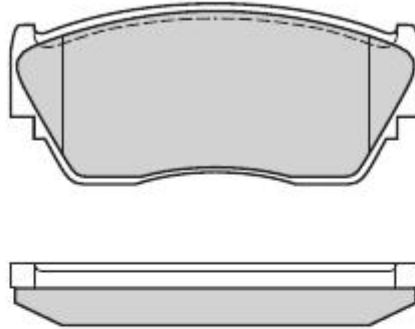



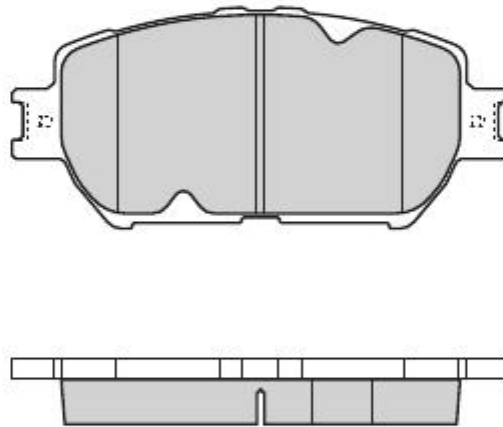



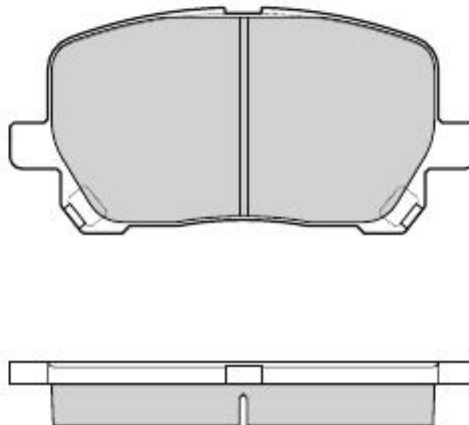

1126	TOYOTA	AKEBONO	X	131,2	58,5	17,3	4		
-------------	--------	---------	---	-------	------	------	---	--	--



1127	TOYOTA	AKEBONO	X	123,1	59,6	17	4		
-------------	--------	---------	---	-------	------	----	---	--	--

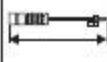

									
1128	DODGE - MITSUBISHI	SUMITOMO	X	119,4	A 65,3 B 74,8	15	2A-2B		

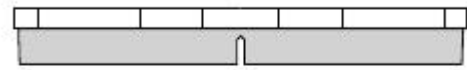
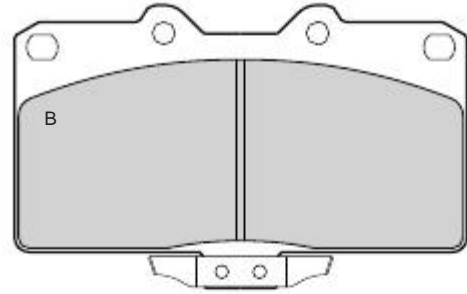
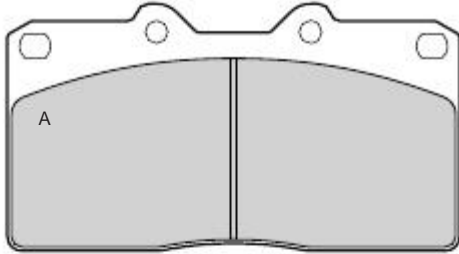



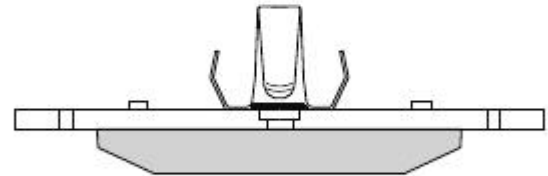
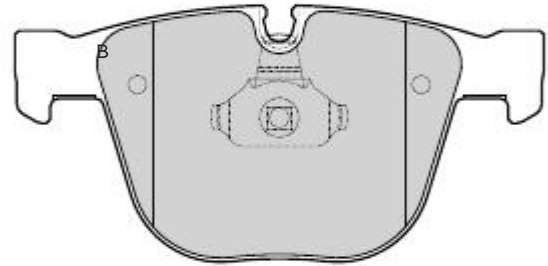
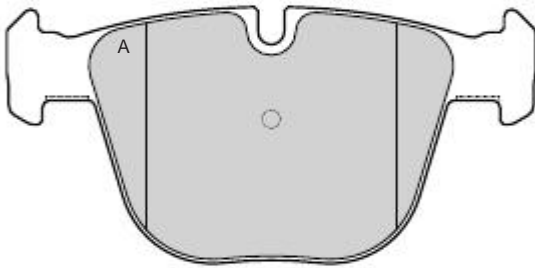



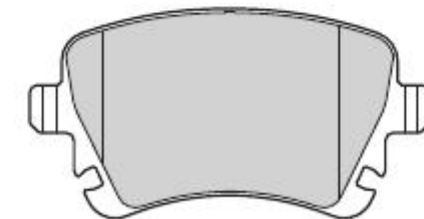

1129	BMW	ATE	X	139,7	67,9	16,8	2A-2B		
-------------	-----	-----	---	-------	------	------	-------	--	--



1130	AUDI - VOLKSWAGEN	LUCAS	X	105,5	56	17	4		
-------------	-------------------	-------	---	-------	----	----	---	--	--

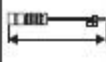

									
1131	FIAT	ATE	X	156,3	52,6	17,5	2A-2B		

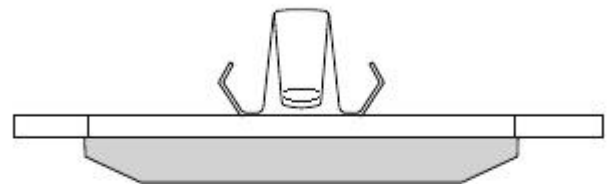
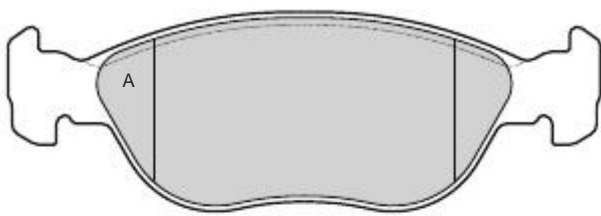



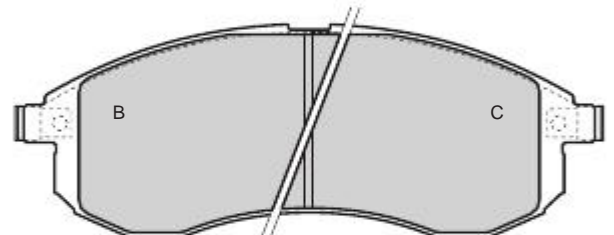
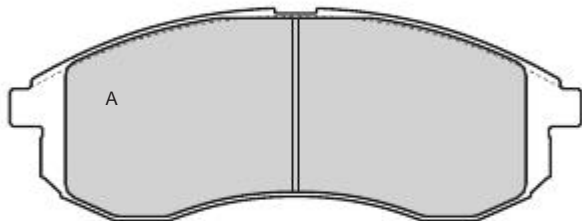



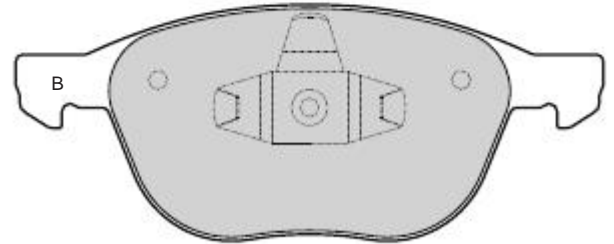











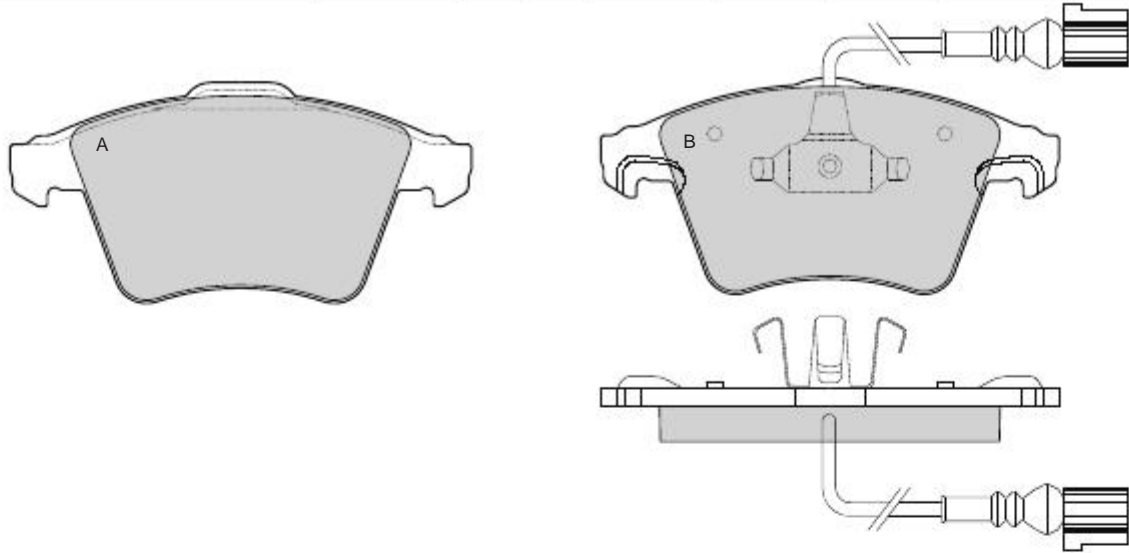
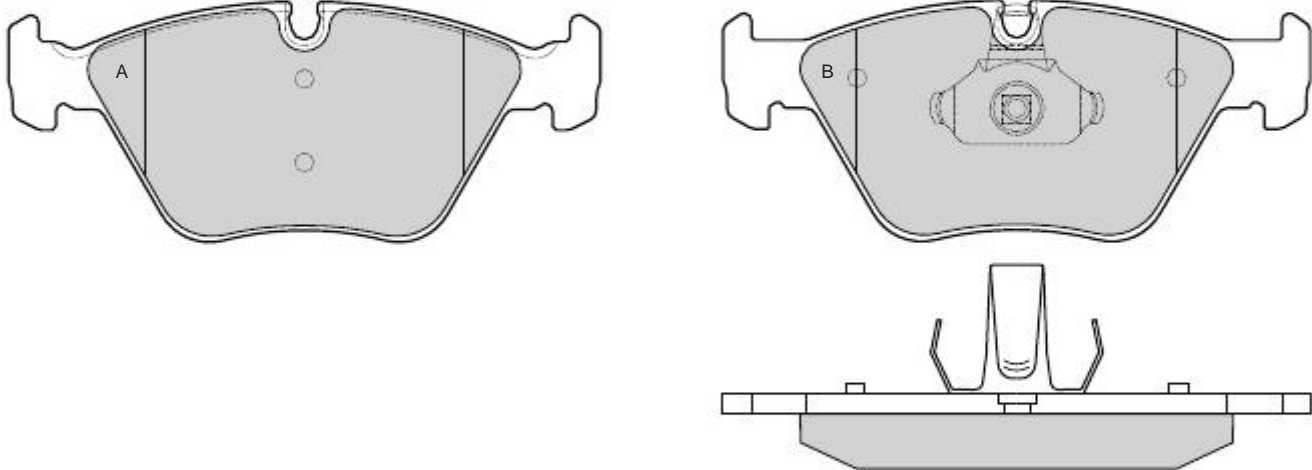
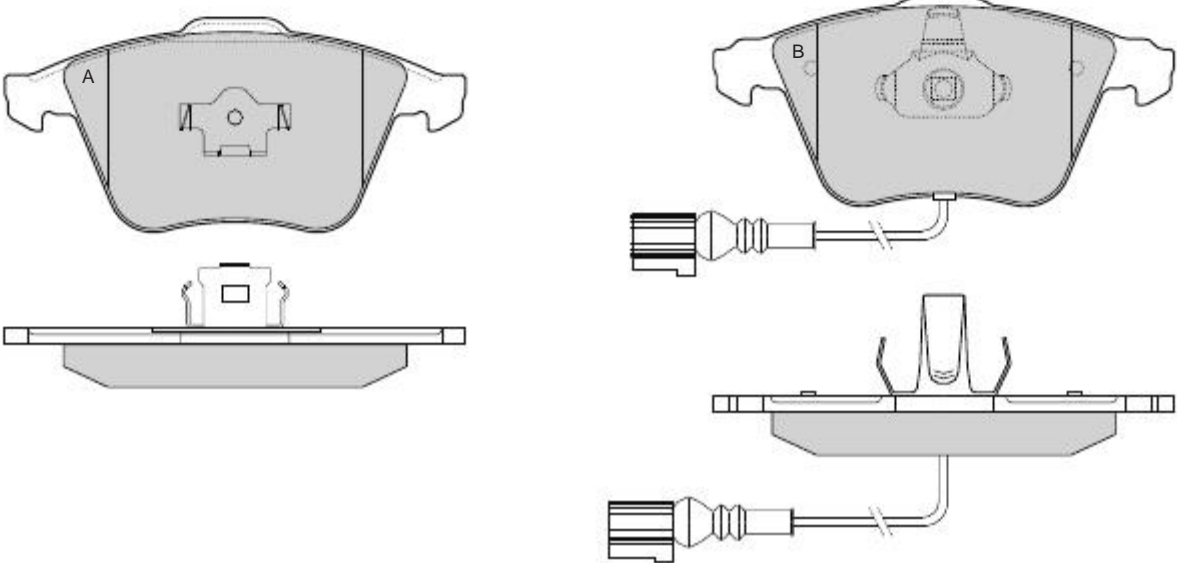

1132	MITSUBISHI	AKEBONO	X	150,9	56,3	15,5	2A 1B-1C		
------	------------	---------	---	-------	------	------	-------------	--	--



1133	FORD - MAZDA - VOLVO	ATE	X	A 156,3 B 155,1	A 67 B 62,4	18,3	2A-2B		
------	----------------------	-----	---	--------------------	----------------	------	-------	--	--

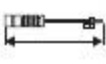

									
1134	VOLKSWAGEN	ATE	X	A 156,4 B 155,2	A 74,9 B 73,4	18	2A-2B	2	200
									
1135	BMW	ATE	X	A 156,3 B 155,1	64,2	20	2A-2B		
									
1136	AUDI	ATE	X	A 156,2 B 155	72,9	20	2A-2B	2	180
									

									
1137	AUDI	ATE	X	193,2	72,6	20,3	2A-2B	2	250

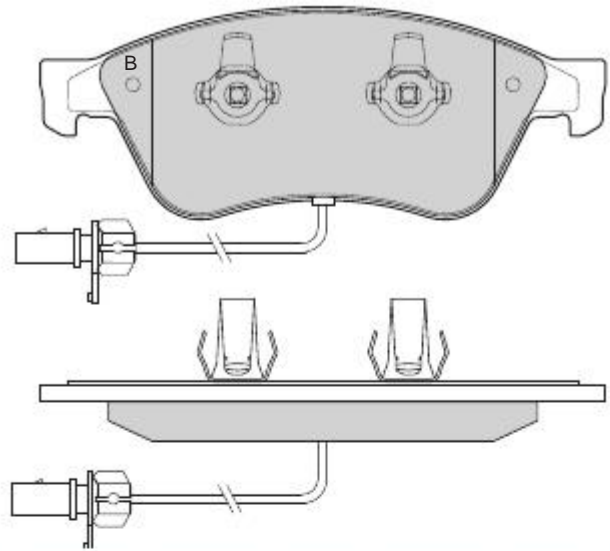
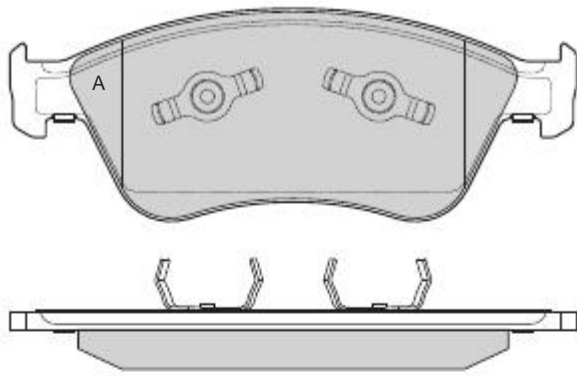



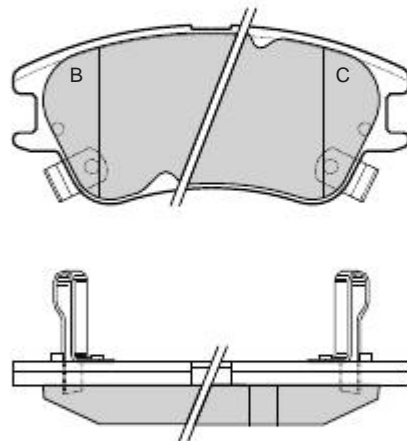
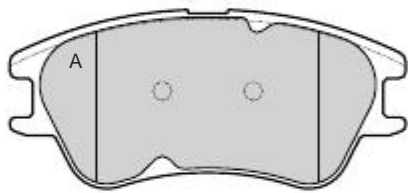



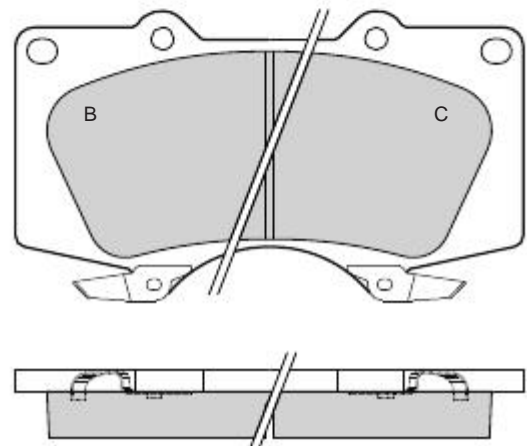
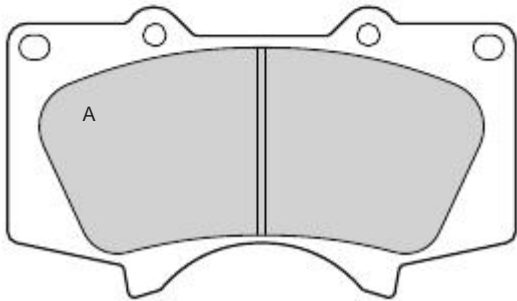



1138	HYUNDAI	MANDO	X	104,6	47,2	16,4	2A 1B-1C		
------	---------	-------	---	-------	------	------	-------------	--	--



1139	TOYOTA	SUMITOMO	X	134,2	76,9	17,8	2A 1B-1C		
------	--------	----------	---	-------	------	------	-------------	--	--



									
1140	VOLKSWAGEN	LUCAS	X	116,2	58,6	17,5	4	1	170

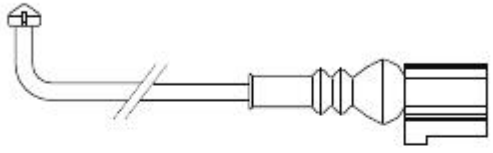



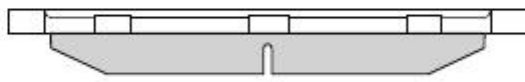
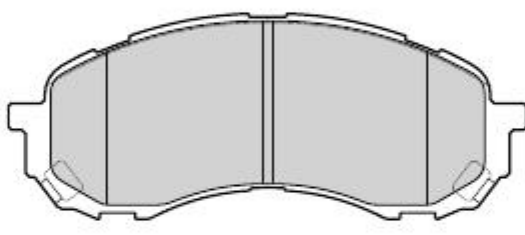



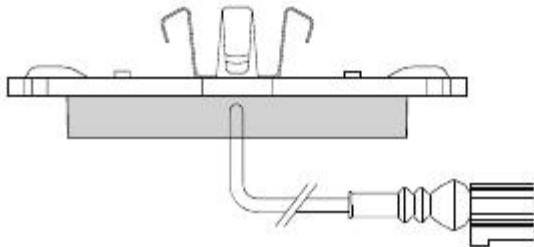
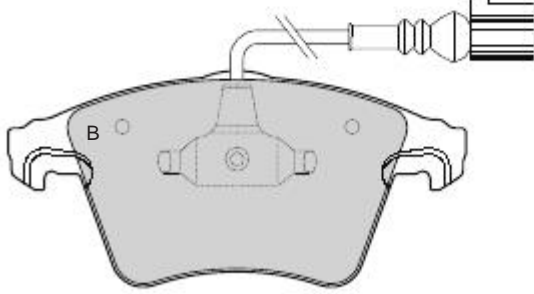

1141	SUBARU	AKEBONO	X	137	54,4	16,9	4		
------	--------	---------	---	-----	------	------	---	--	--



1142	VOLKSWAGEN	ATE	X	A 156,4 B 155,2	A 74,9 B 73,4	20	2A-2B	2	310
------	------------	-----	---	--------------------	------------------	----	-------	---	-----

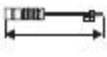

									
1143	HYUNDAI	MANDO	X	110,3	46,5	15,8	2A 1B-1C		

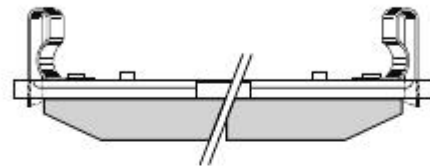
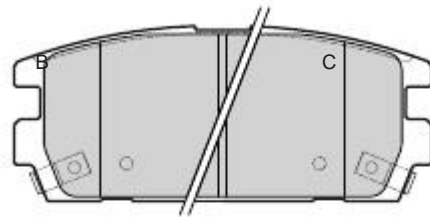
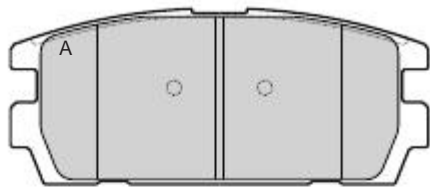



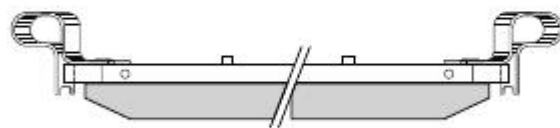
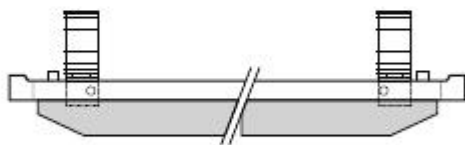
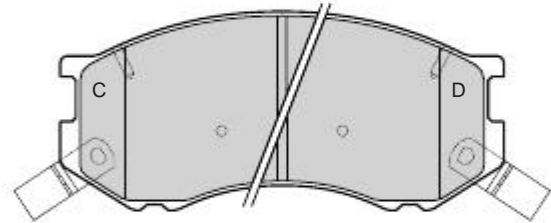
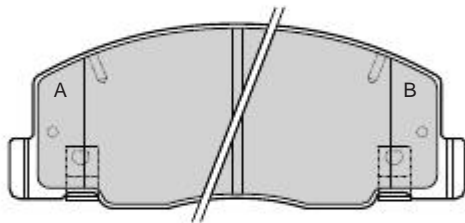



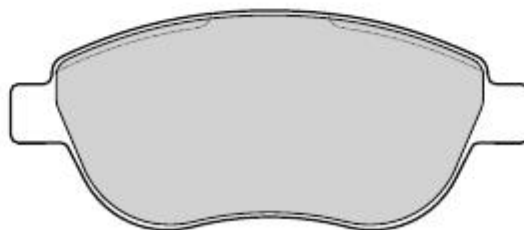

1144	TOYOTA	SUMITOMO	X	A-B 128,4 C-D 126,7	A-B 52 C-D 55	15,5	1A-1B 1C-1D		
-------------	--------	----------	---	------------------------	------------------	------	----------------	--	--



1145	FIAT	BOSCH	X	136,8	57,9	18,3	4		
-------------	------	-------	---	-------	------	------	---	--	--

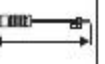

									
1146	HYUNDAI - KIA	MANDO	X	131,5	60,1	17,5	2A 1B-1C		

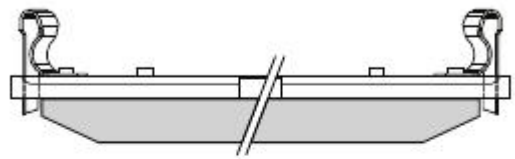
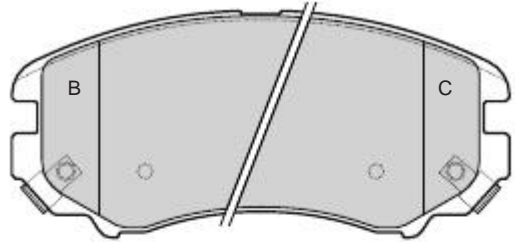
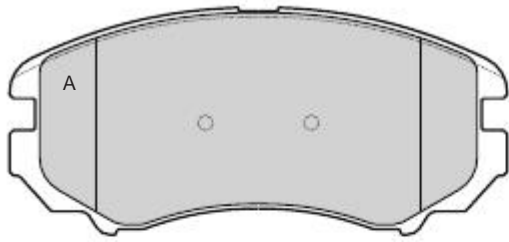



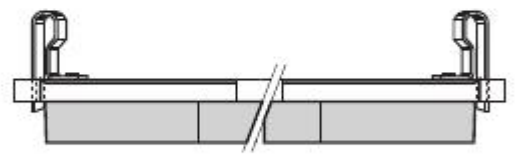
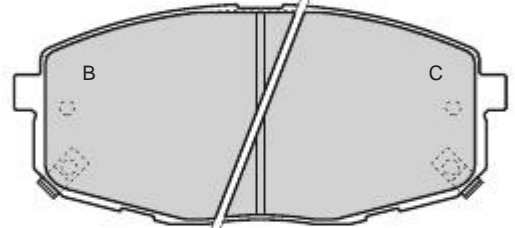
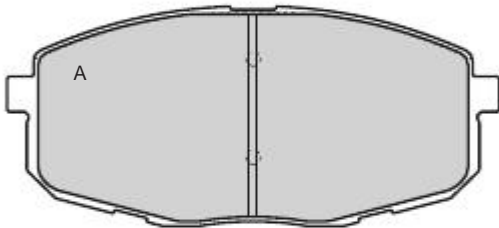



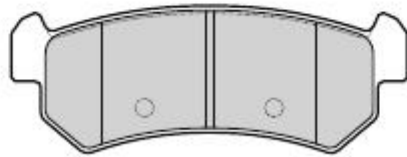



1147	KIA	MANDO	X	130	58,2	16,8	2A 1B-1C		
------	-----	-------	---	-----	------	------	-------------	--	--



1148	DAEWOO	AKEBONO	X	104,5	39	14,6	4		
------	--------	---------	---	-------	----	------	---	--	--



									
1149	AUDI	ATE	X	A 77,5 B-C 63,5	A 74,6 B-C 75,4	17,5	4A 2B-2C	2	270

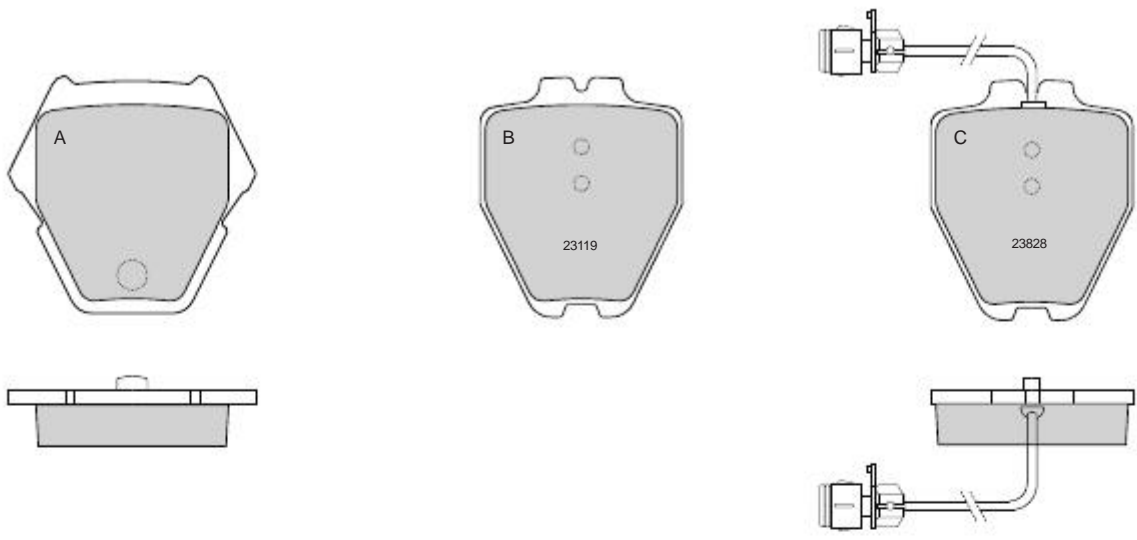



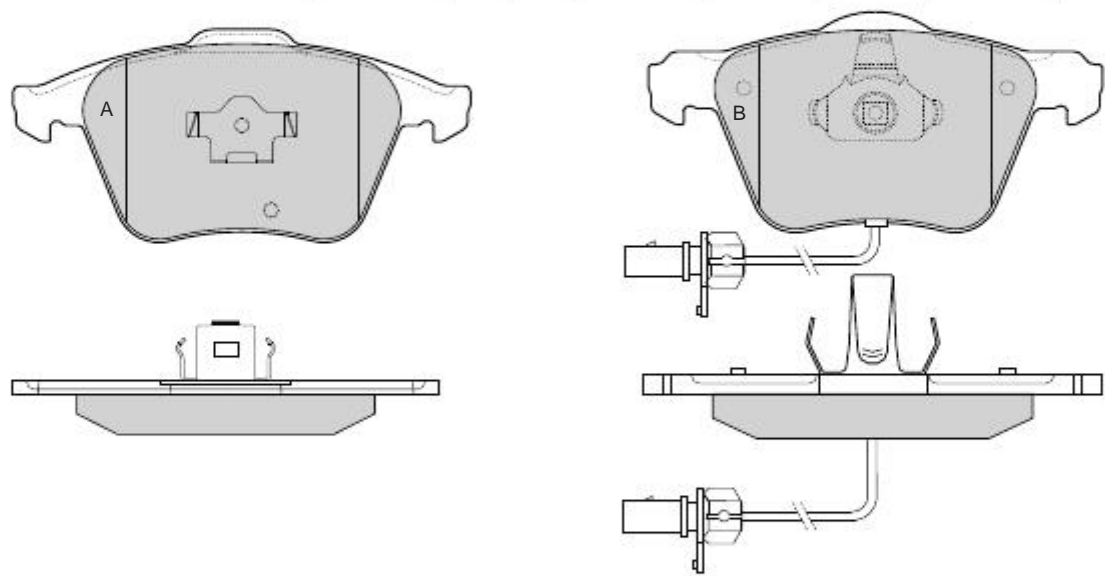



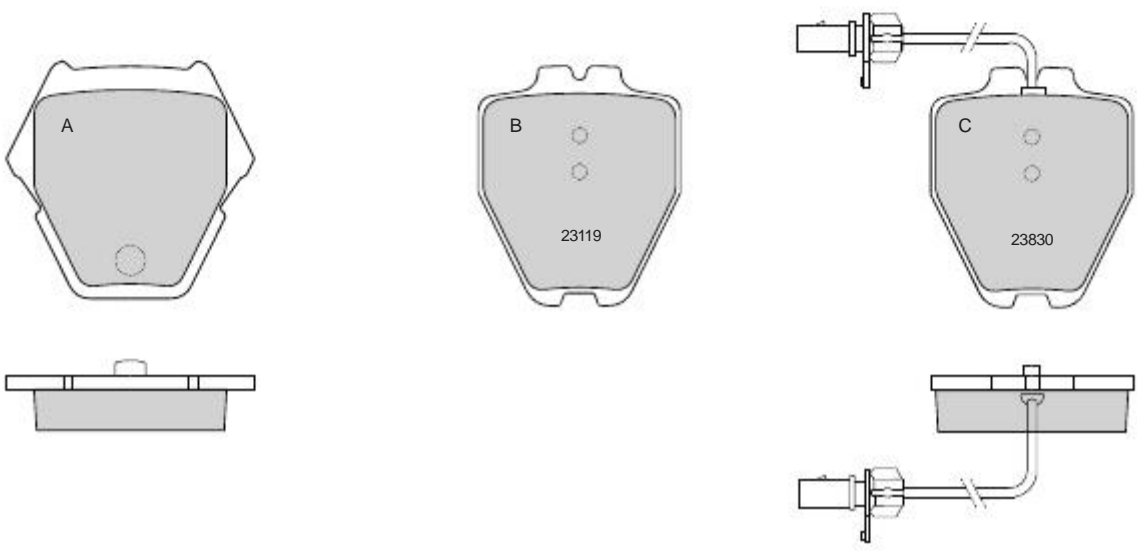



1150	AUDI	ATE	X	A 156,3 B 155,2	A 74,3 B 75,3	A 19,5 B 20,8	2A-2B	2	285
------	------	-----	---	--------------------	------------------	------------------	-------	---	-----



1151	VOLKSWAGEN	GIRLING	X	A 77,5 B-C 63,5	A 74,6 B-C 75,4	18,3	4A 2B-2C	2	285
------	------------	---------	---	--------------------	--------------------	------	-------------	---	-----



Reference in this Catalogue to other manufacturers and to part numbers and other descriptions are for identification purposes only, because the above **DISC BRAKE PADS** are **NOT ORIGINAL** but with these interchangeable

									
1152	VOLKSWAGEN	BREMBO	X	131,7	75	18	2A-2B	2	300

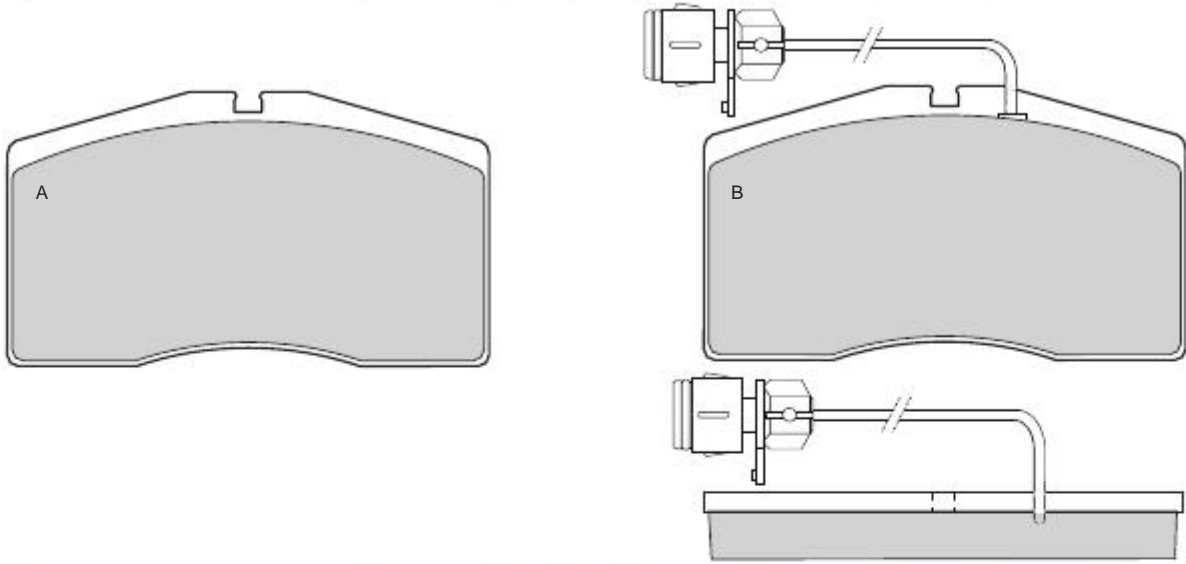



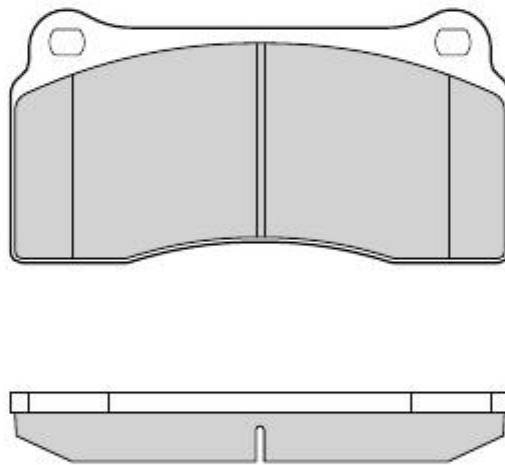



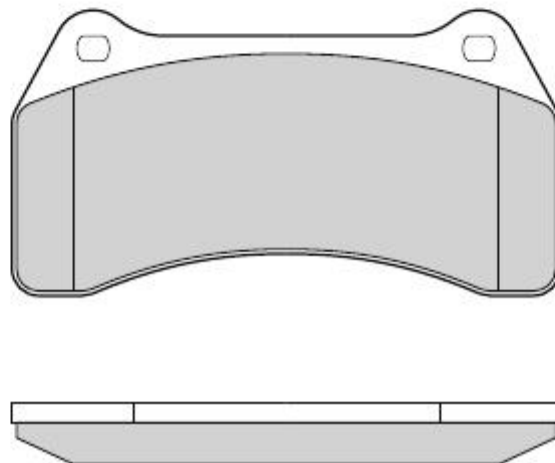



1153	JAGUAR	BREMBO	X	131,8	67	18	4		
-------------	--------	--------	---	-------	----	----	---	--	--



1154	JAGUAR	BREMBO	X	144,9	75,5	16	4		
-------------	--------	--------	---	-------	------	----	---	--	--



									
1155	JAGUAR - SEAT	BREMBO	X	109,7	69,3	14,8	4		

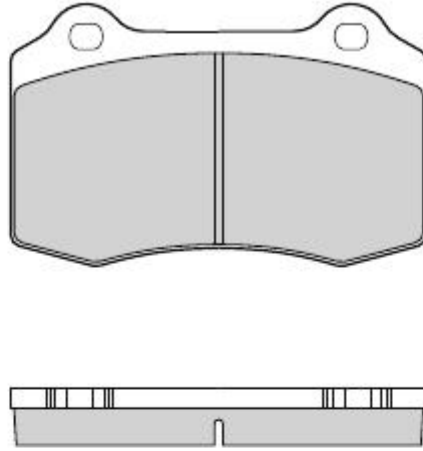



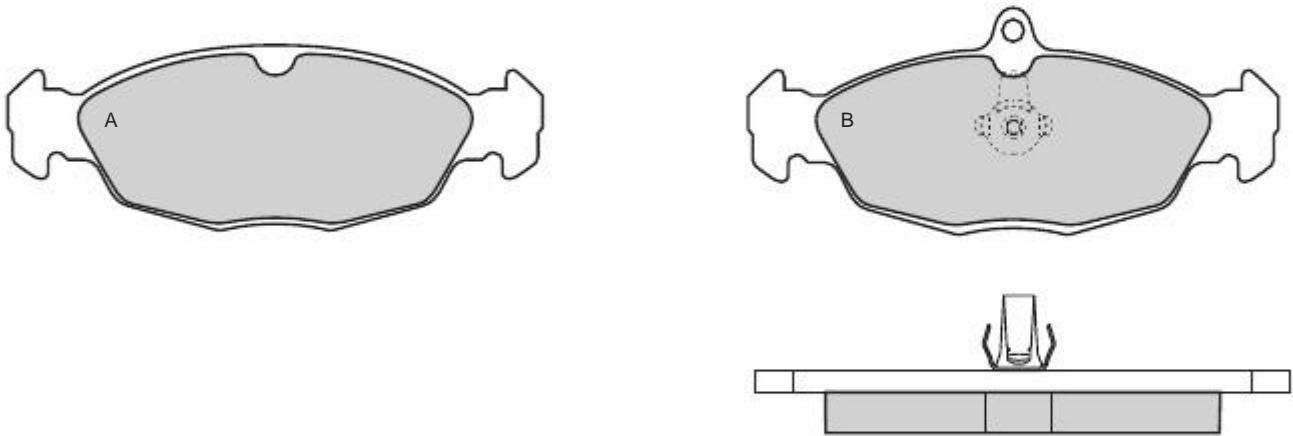



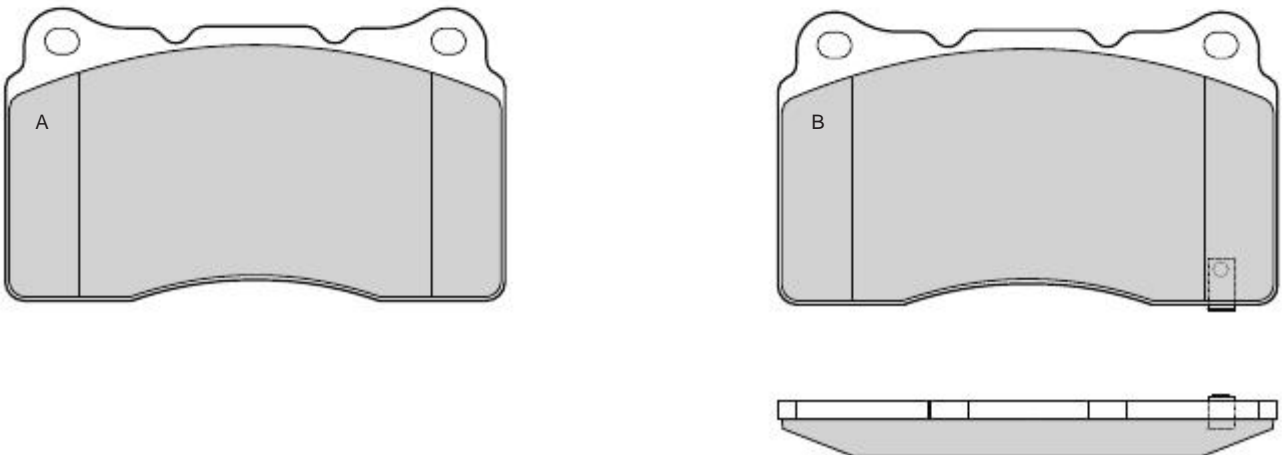



1156	JAGUAR - SUBARU	ATE	X	A 141,3 B 140,1	A 48,3 B 58,3	16,5	2A-2B		
-------------	-----------------	-----	---	--------------------	------------------	------	-------	--	--



1157	SUBARU	BREMBO	X	131,8	77,3	14,8	2A-2B		
-------------	--------	--------	---	-------	------	------	-------	--	--



									
1158	SUBARU	AKEBONO	X	137	56,8	17,8	2A 1B-1C		

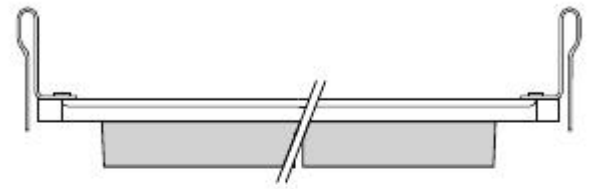
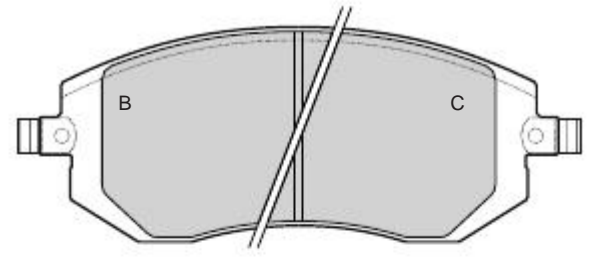
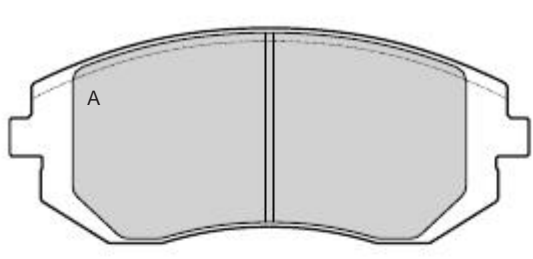



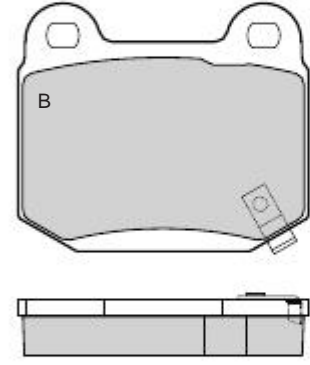
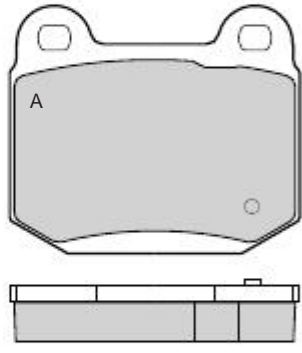



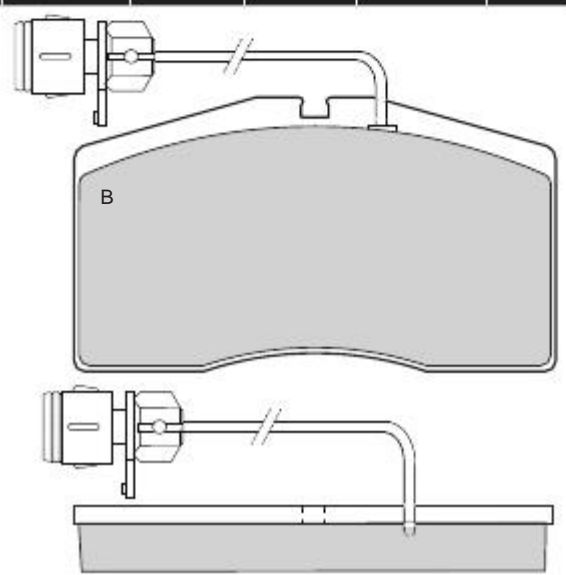
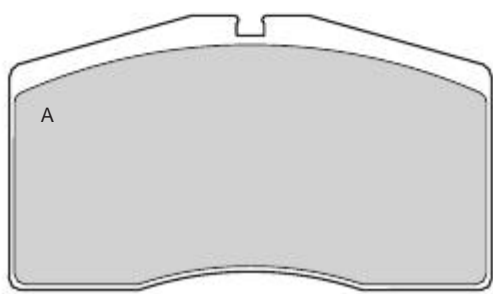

1159	NISSAN - SUBARU	ATE	X	76,6	65,5	14,8	2A-2B		
------	-----------------	-----	---	------	------	------	-------	--	--



1160	AUDI	BREMBO	X	131,7	75	17,3	2A-2B	2	255
------	------	--------	---	-------	----	------	-------	---	-----

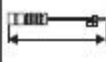

									
1161	SEAT	BREMBO	X	109,7	69,3	14,8	3A-1B		330

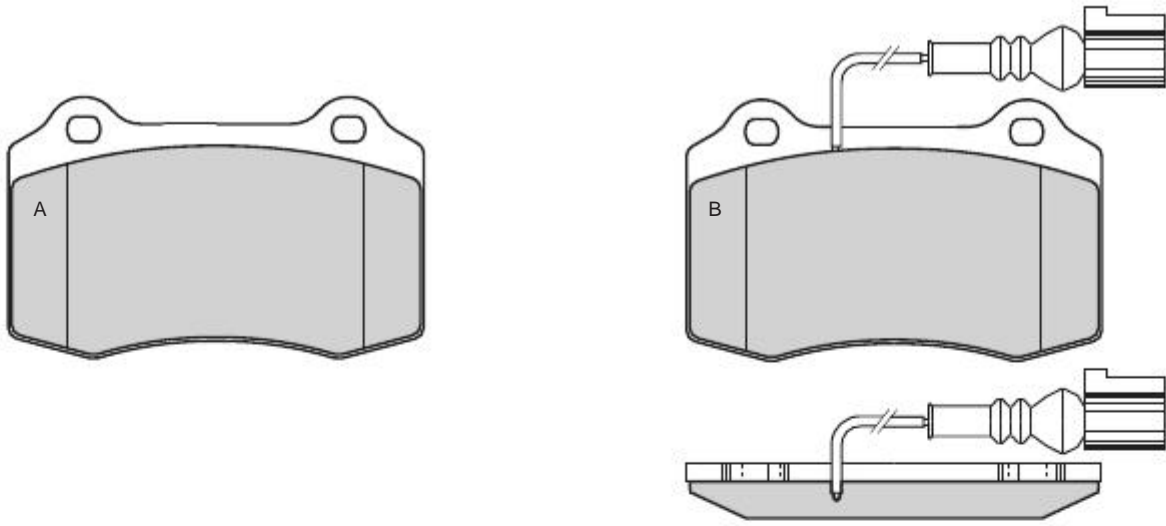



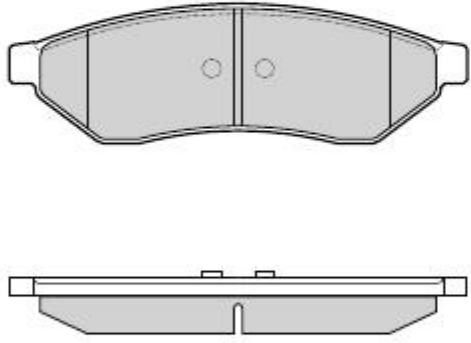



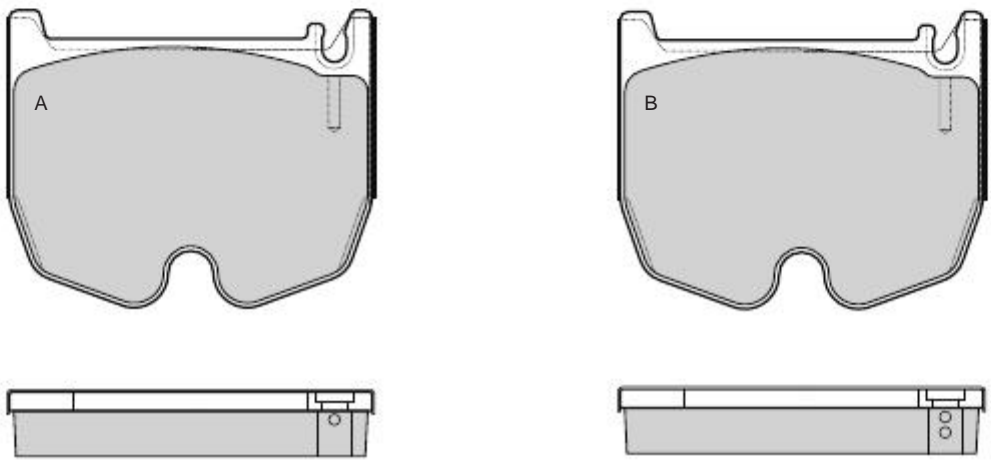

1162	DAEWOO	AKEBONO	X	121	37,3	14,8	4		
-------------	--------	---------	---	-----	------	------	---	--	--



1163	MERCEDES	BREMBO	X	97	78,5	17	4A-4B		
-------------	----------	--------	---	----	------	----	-------	--	--

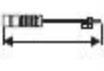

Reference in this Catalogue to other manufacturers and to part numbers and other descriptions are for identification purposes only, because the above **DISC BRAKE PADS** are **NOT ORIGINAL** but with these interchangeable

									
1164	MERCEDES	BREMBO	X	111,5	63,9	15,8	4		

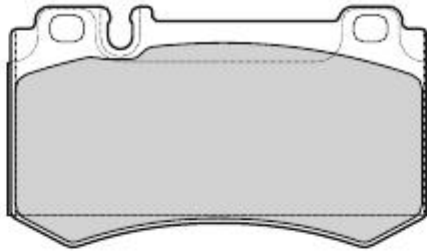



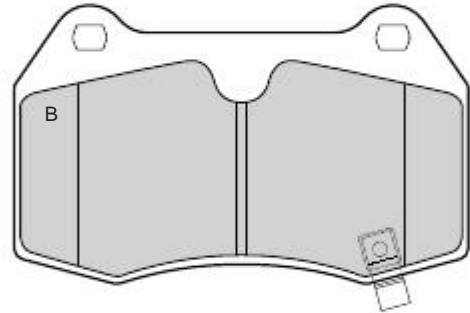
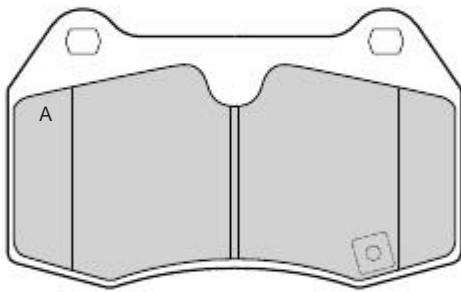



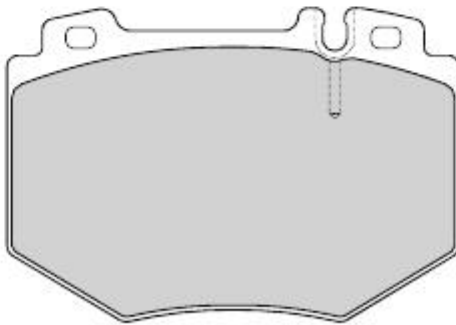

1165	NISSAN	BREMBO	X	119,8	73,6	15	2A-2B		
-------------	--------	--------	---	-------	------	----	-------	--	--



1166	MERCEDES	BREMBO	X	119,4	82,9	17,4	4		
-------------	----------	--------	---	-------	------	------	---	--	--

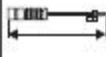

									
1167	VOLVO	BREMBO	X	131,8	77,3	15,8	4		

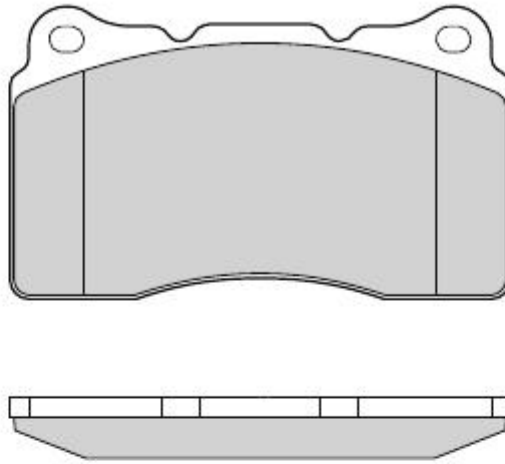



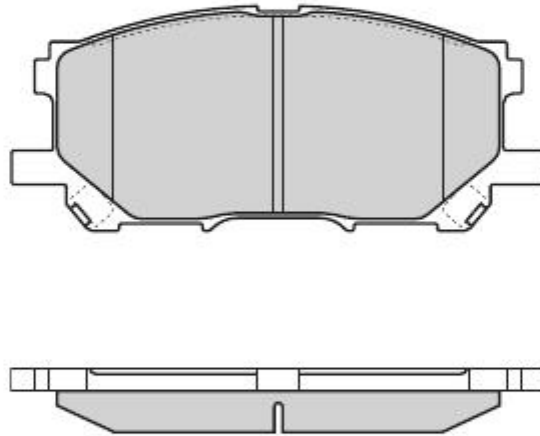



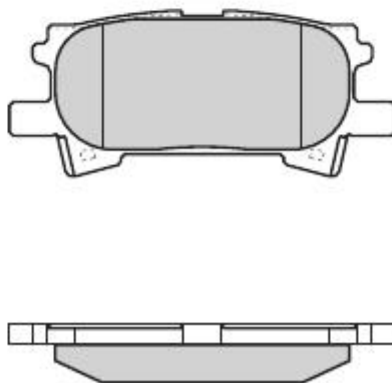



1168	LEXUS	SUMITOMO	X	140,8	59,5	16,8	4		
-------------	-------	----------	---	-------	------	------	---	--	--



1169	LEXUS	SUMITOMO	X	101,8	43,9	15,5	4		
-------------	-------	----------	---	-------	------	------	---	--	--



									
1170	MAZDA	SUMITOMO	X	137,8	62	17,3	4		

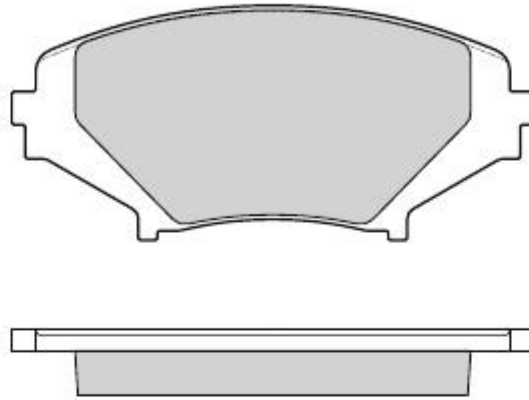



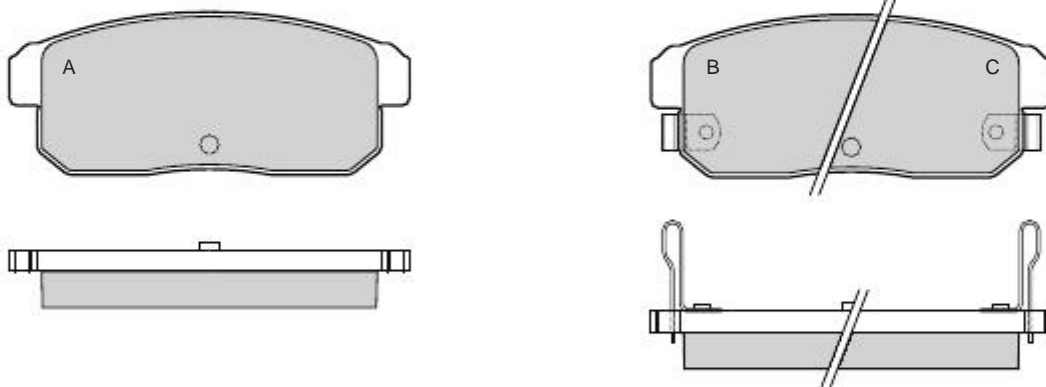



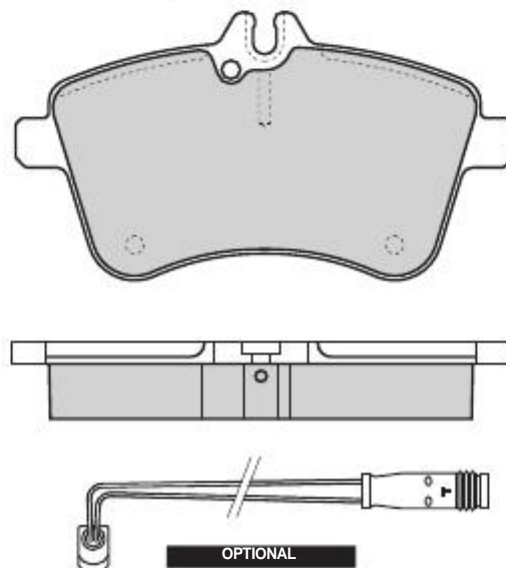

1171	MAZDA	SUMITOMO	X	105,7	43	15,1	2A 1B-1C		
-------------	-------	----------	---	-------	----	------	-------------	--	--



1172	MERCEDES	BOSCH	X	131,5	70,8	20	4	1	100
-------------	----------	-------	---	-------	------	----	---	---	-----

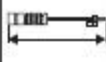

									
1173	BMW	ATE	X	122	A 59,2 B 58,2	17	2A-2B		

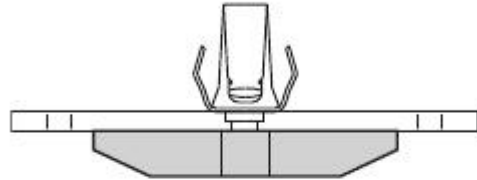
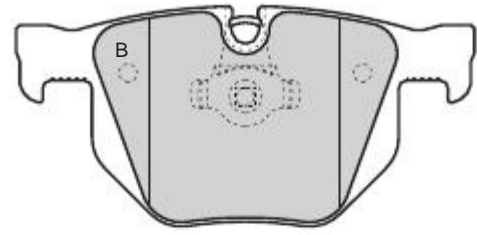
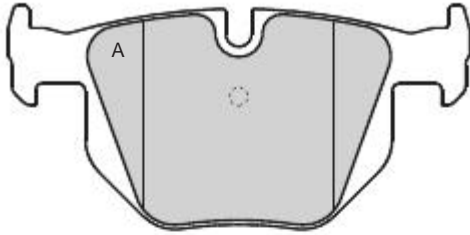



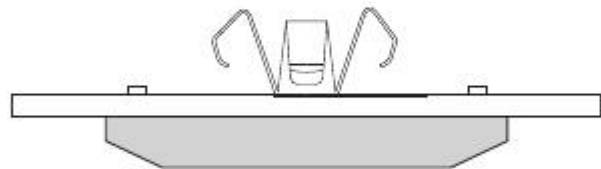
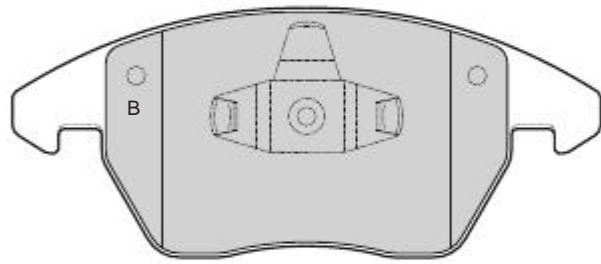
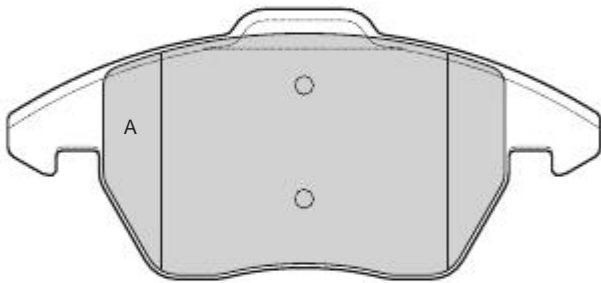



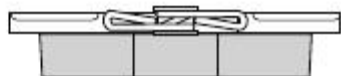
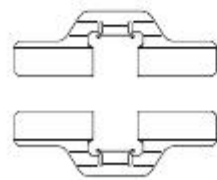



1174	PEUGEOT	ATE	X	155,2	71,4 66	19	2A-2B		
------	---------	-----	---	-------	------------	----	-------	--	--



1175	AUDI - VOLKSWAGEN	LUCAS	X	87	52,9	17	4		
------	-------------------	-------	---	----	------	----	---	--	--



									
1176	PORSCHE	BREMBO	X	112,2	73	15,2	4		

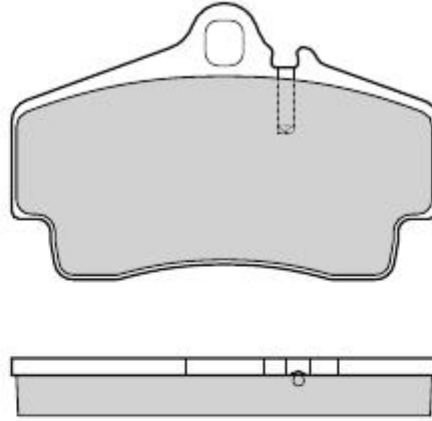



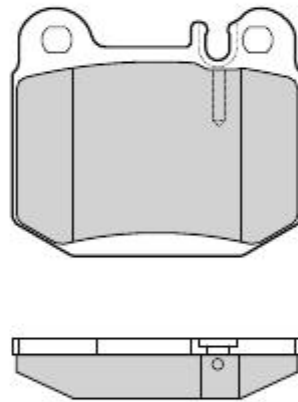



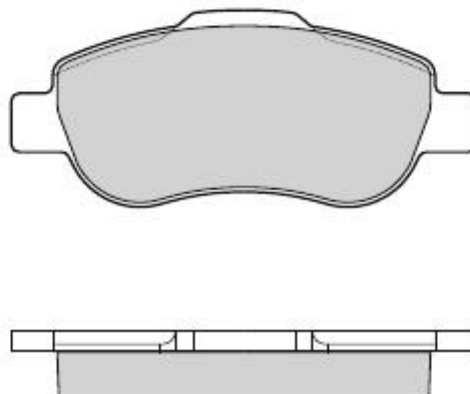

1177	MERCEDES	ATE	X	76,5	65,5	16	4		
-------------	----------	-----	---	------	------	----	---	--	--



1178	FIAT	BOSCH	X	122,8	52	17,4	4		
-------------	------	-------	---	-------	----	------	---	--	--

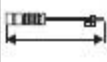

									
1179	PORSCHE	BREMBO	X		114	78	16	4	

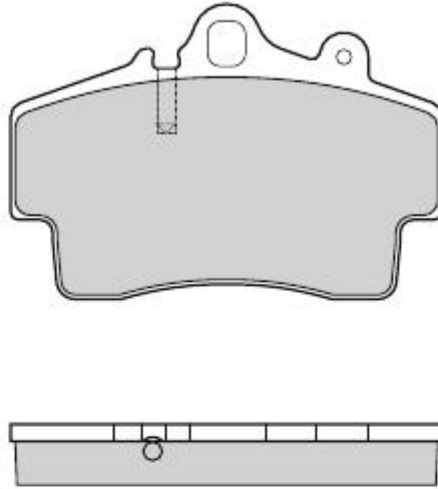



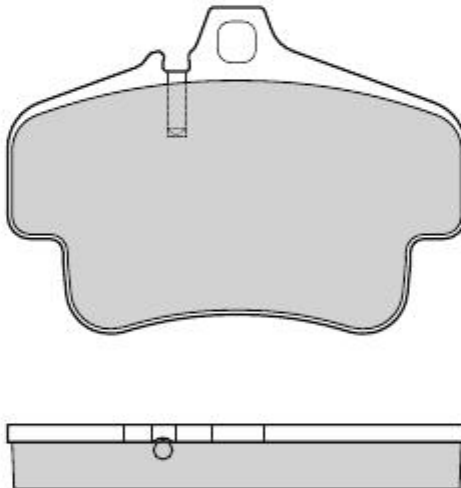



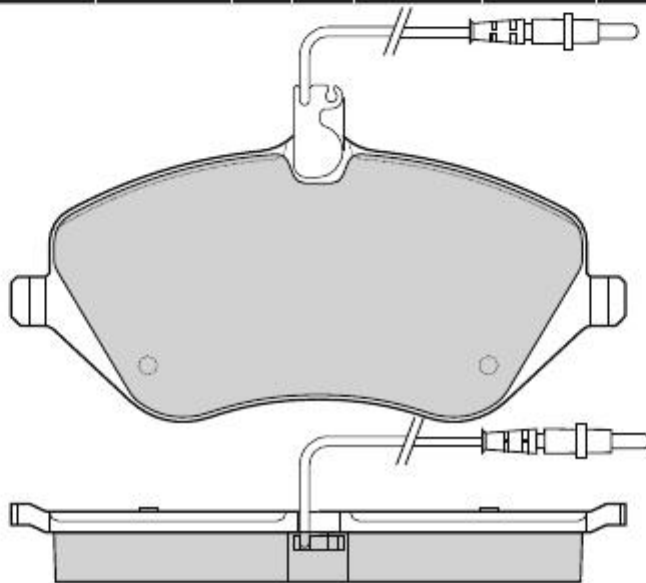

1180	PORSCHE	BREMBO	X	X	121	86,2	17	4	
-------------	---------	--------	---	---	-----	------	----	---	--



1181	PEUGEOT	LUCAS	X		162,3	79,1	18,4	4	4	350
-------------	---------	-------	---	--	-------	------	------	---	---	-----

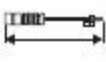

									
1182	PEUGEOT	LUCAS	X	131,4	66,8	19,5	4	4	350

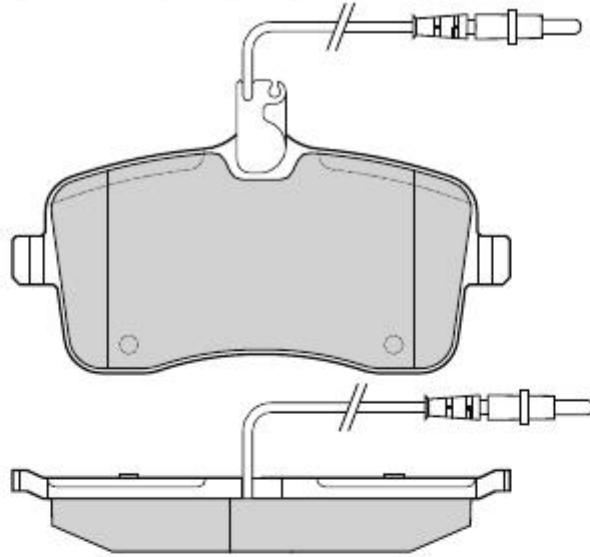



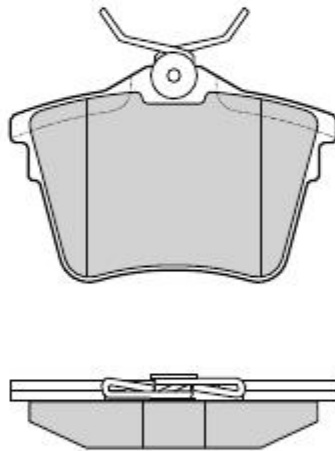



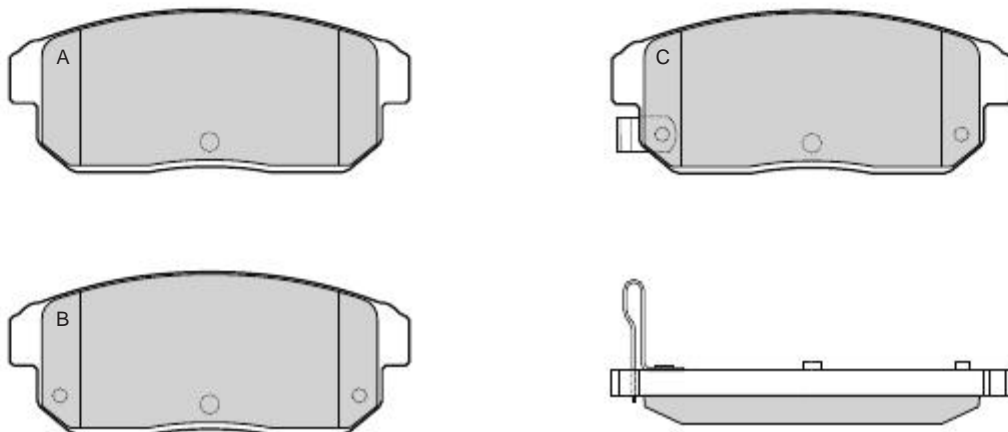



1183	PEUGEOT	LUCAS	X	86,2	57	17,8	4		
------	---------	-------	---	------	----	------	---	--	--



1184	SUZUKI	SUMITOMO	X	105,5	43	14	2A 1B-1C		
------	--------	----------	---	-------	----	----	-------------	--	--



									
1185	HONDA	ATE	X	155,2	A 64,75 B-C 68,35	17	2A 1B-1C		

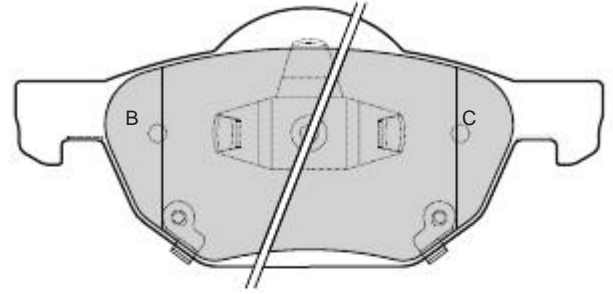



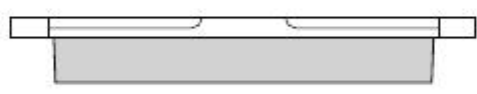
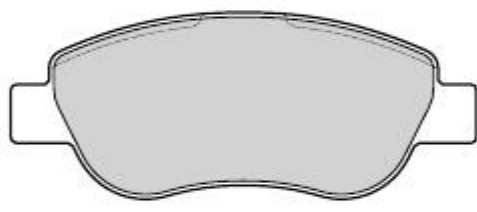



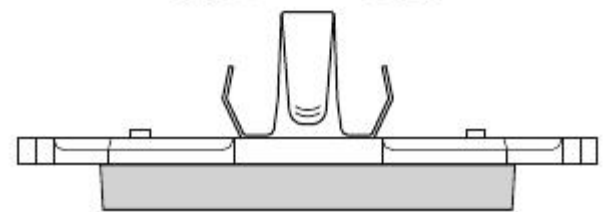
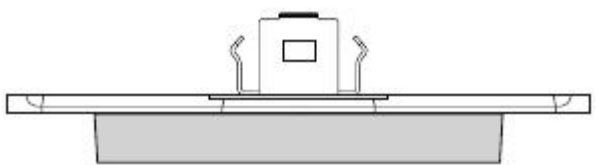
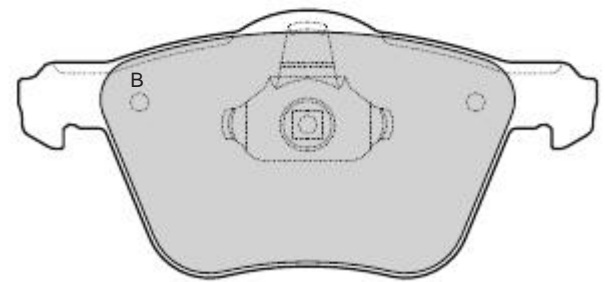



1186	RENAULT	BOSCH	X	122,9	49,3	17,4	4		
-------------	---------	-------	---	-------	------	------	---	--	--



1187	VOLVO	ATE	X	A 156,1 B 154,9	A 70,8 B 71,8	A 17,5 B 19	2A-2B		
-------------	-------	-----	---	--------------------	------------------	----------------	-------	--	--



									
1188	FORD	BENDIX	X	115,7	53,7	14,7	4		

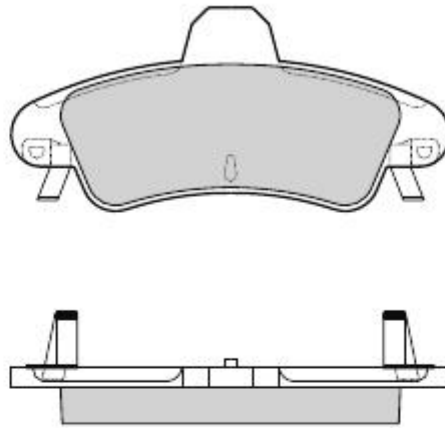



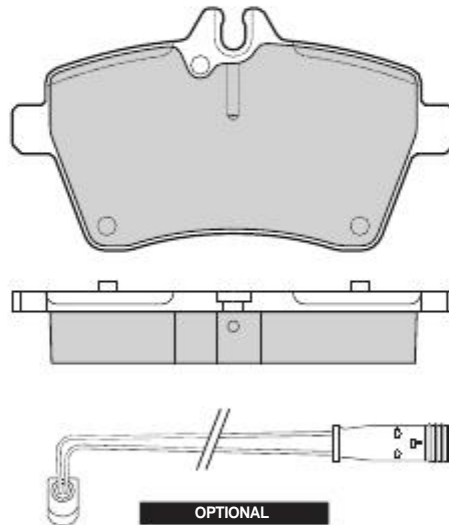



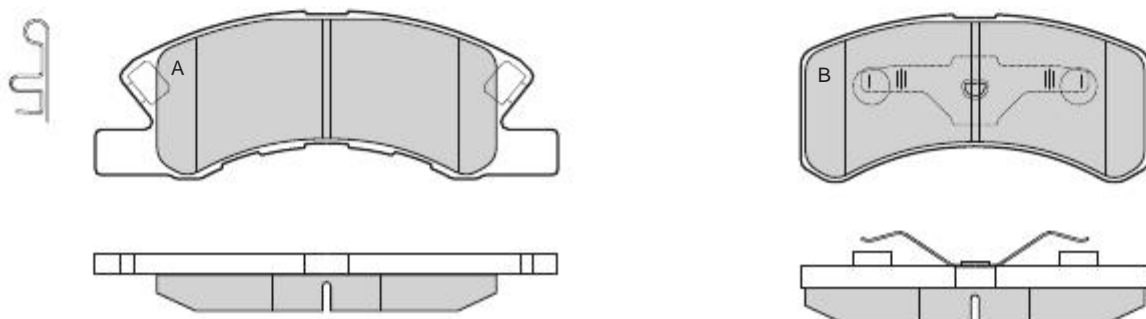



1189	MERCEDES	BOSCH	X	116,7	64	19	4	2	100
------	----------	-------	---	-------	----	----	---	---	-----



1190	DAIHATSU	AKEBONO	X	A 122,1 B 92	44,4	15	2A-2B		
------	----------	---------	---	-----------------	------	----	-------	--	--



									
1191	TOYOTA	AKEBONO	X	125,5	59,5	17	4		

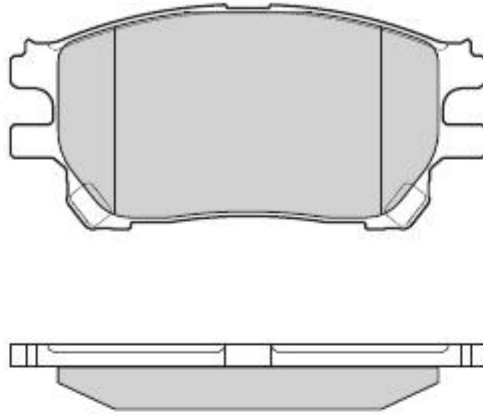



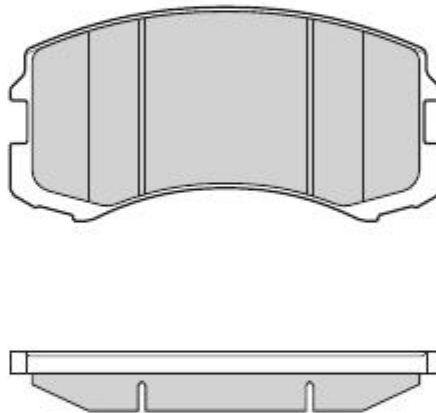



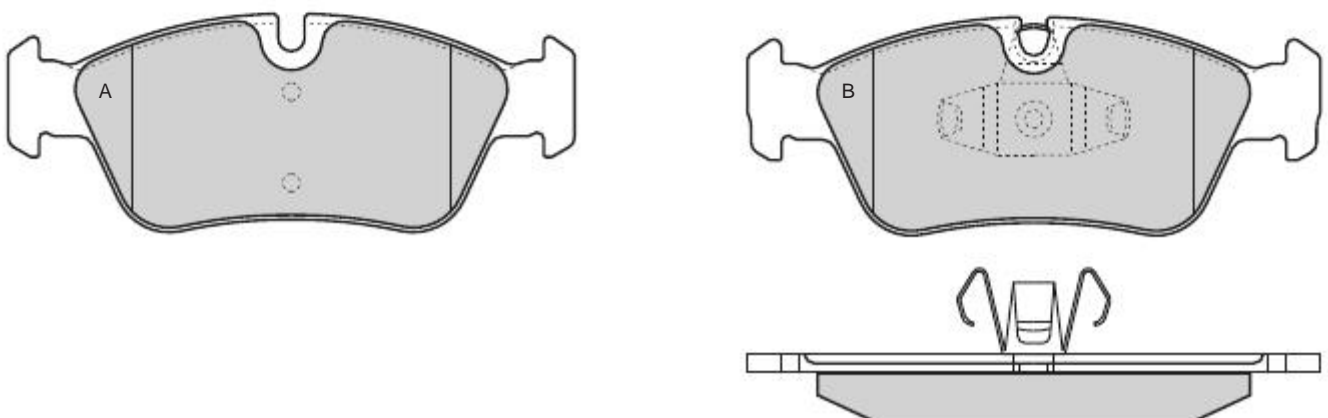

1192	MITSUBISHI	SUMITOMO	X	113,8	56,5	15,4	4		
-------------	------------	----------	---	-------	------	------	---	--	--



1193	BMW	ATE	X	A 149,5 B 150,1	57,5	17,8	2A-2B		
-------------	-----	-----	---	--------------------	------	------	-------	--	--

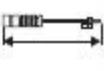

									
1194	BMW	ATE	X	123	A 48,1 B 43,6	17,3	2A-2B		

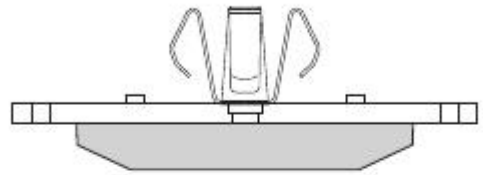
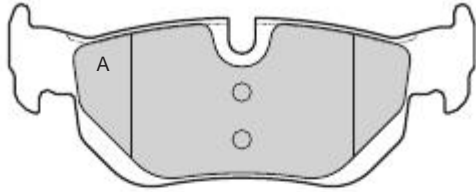



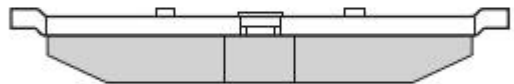
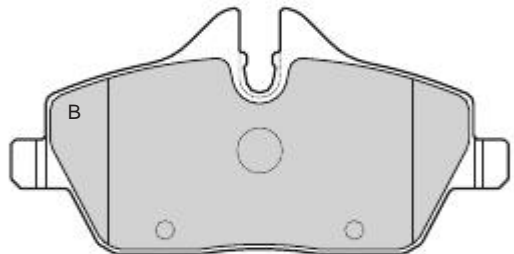
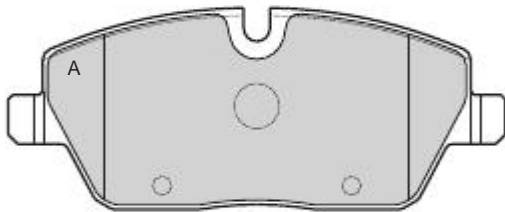



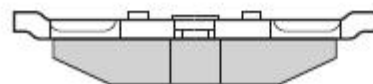
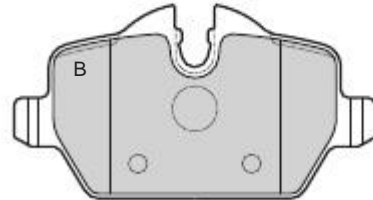
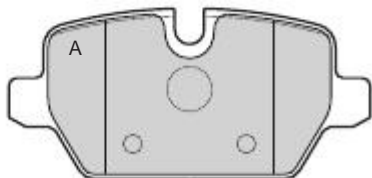

1195	BMW	LUCAS	X	131,4	A 53,3 B 65,3	17,6	2A-2B		
-------------	-----	-------	---	-------	------------------	------	-------	--	--



1196	BMW	LUCAS	X	95,4	A 45 B 51,7	17	2A-2B		
-------------	-----	-------	---	------	----------------	----	-------	--	--

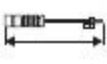

									
1197	HYUNDAI	MANDO	X	131,1	70	17,2	2A 1B-1C		

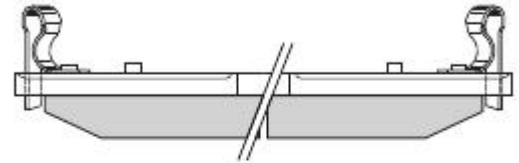
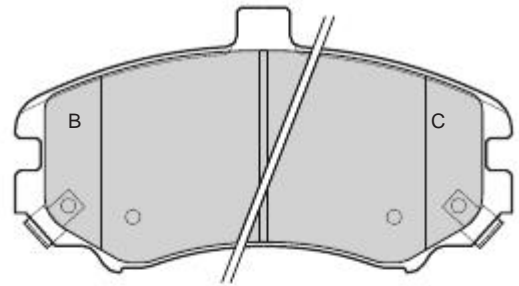
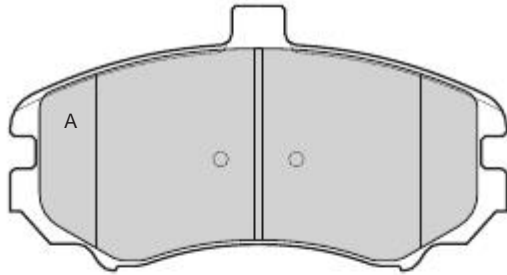



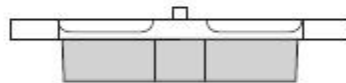
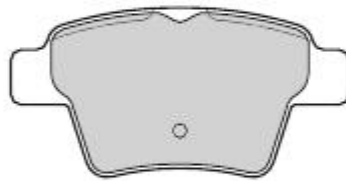



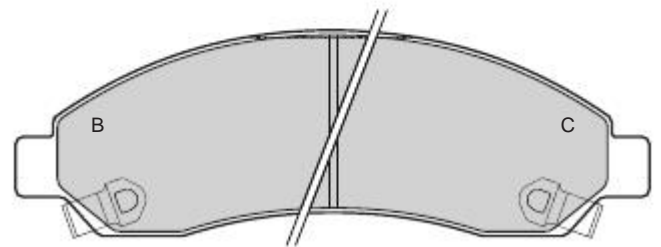
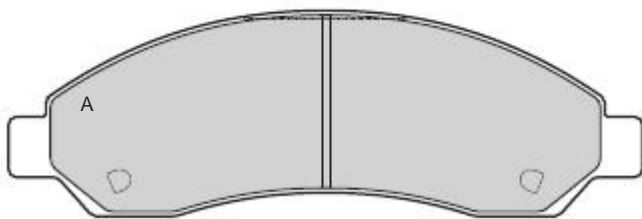



1198	CITROEN	BOSCH	X	95	46,9	17,3	4		
------	---------	-------	---	----	------	------	---	--	--



1199	ISUZU	SUMITOMO	X	167,3	54,3	16,3	2A 1B-1C		
------	-------	----------	---	-------	------	------	-------------	--	--



									
1200	KIA	MANDO	X	165	59	17	2A 1B-1C		

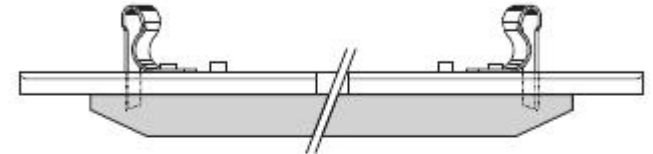
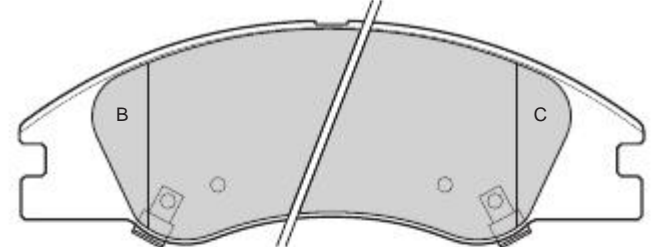
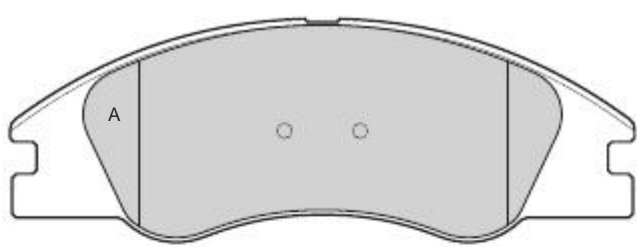



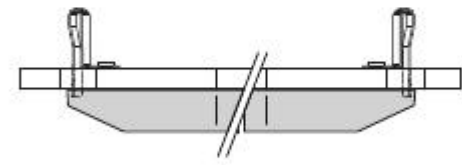
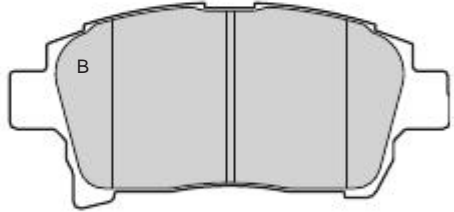
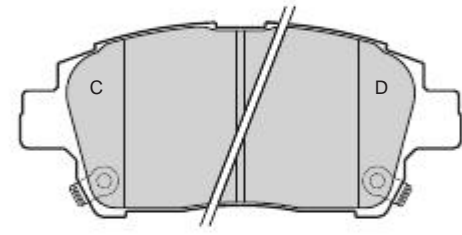
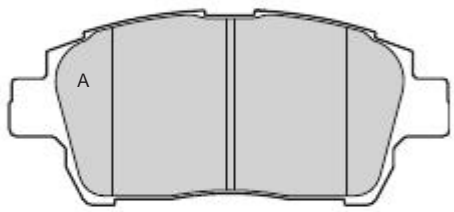



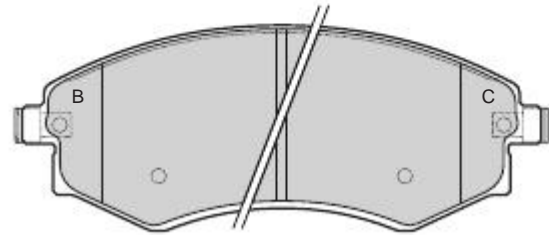
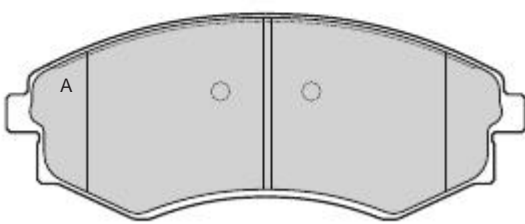

1201	TOYOTA	AKEBONO		116,3	51,6	16,5	1A-1B 1C-2D		
-------------	--------	---------	--	-------	------	------	----------------	--	--



1202	SSANGYONG	AKEBONO	X	137	54,3	16	2A 1B-1C		
-------------	-----------	---------	---	-----	------	----	-------------	--	--

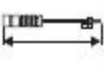

									
1203	SSANGYONG	MANDO	X	98,8	43,5	15	2A 1B-1C		

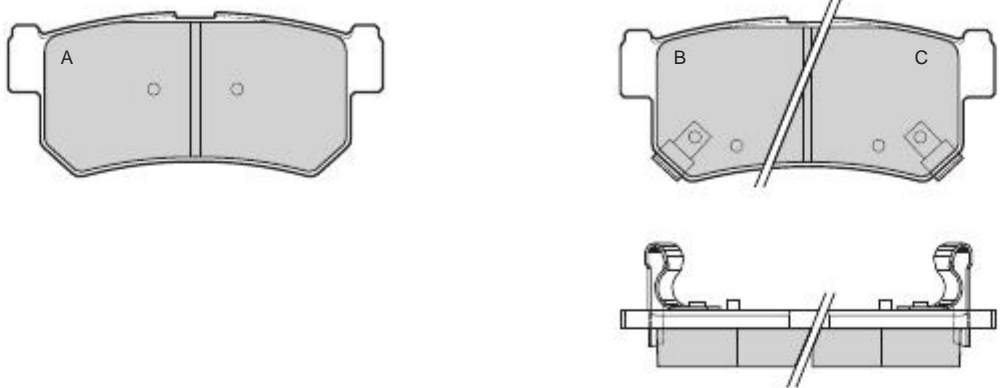

1204	KIA	MANDO	X	115,9	47,4	16	2A 1B-1C		
-------------	-----	-------	---	-------	------	----	-------------	--	--

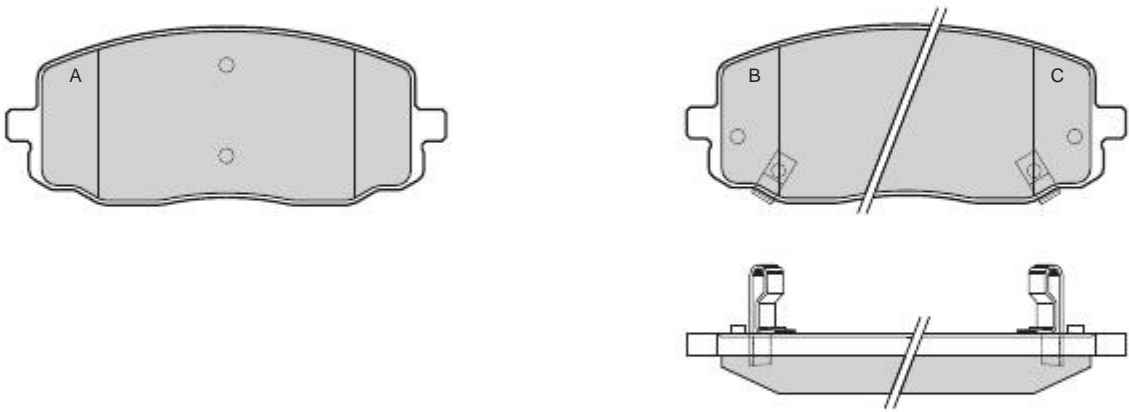

1205	SUZUKI	AKEBONO	X	123	55,3	15,4	4		
-------------	--------	---------	---	-----	------	------	---	--	--

