

<b>1206</b>	LAND ROVER	LUCAS	X	162,2	58,7	18,2	4		

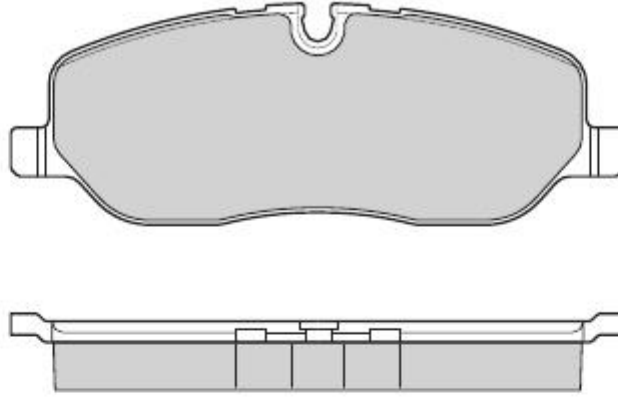

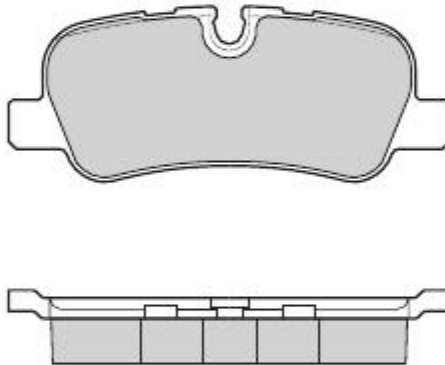

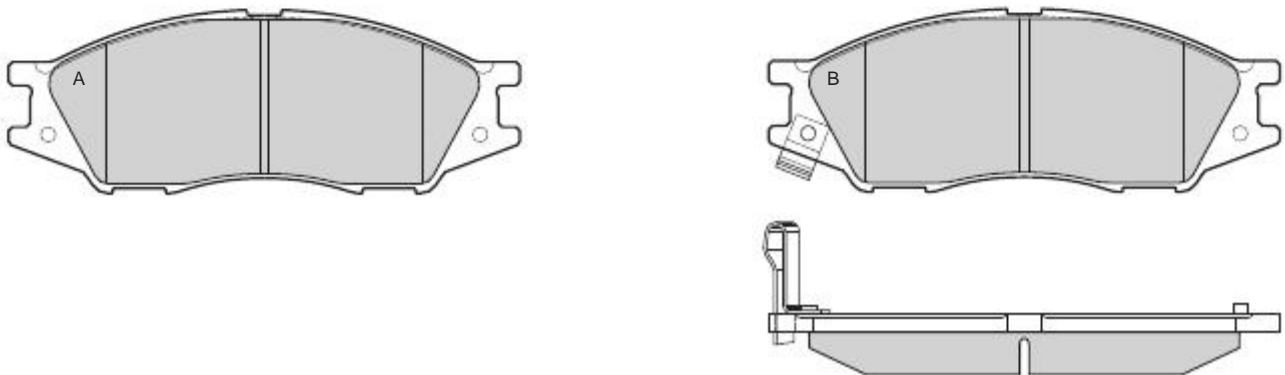







<b>1207</b>	LAND ROVER	LUCAS	X	116,5	46,5	17,4	4		
-------------	------------	-------	---	-------	------	------	---	--	--



<b>1208</b>	NISSAN	AKEBONO	X	134,9	48,5	16,1	3A-1B	2	225
-------------	--------	---------	---	-------	------	------	-------	---	-----



									
<b>1209</b>	TOYOTA	AKEBONO	X	143,3	58,5	16	4		

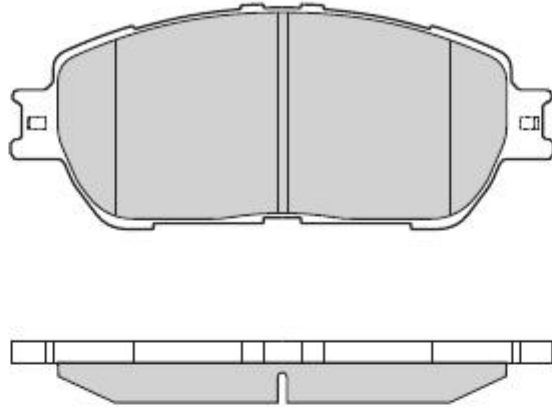



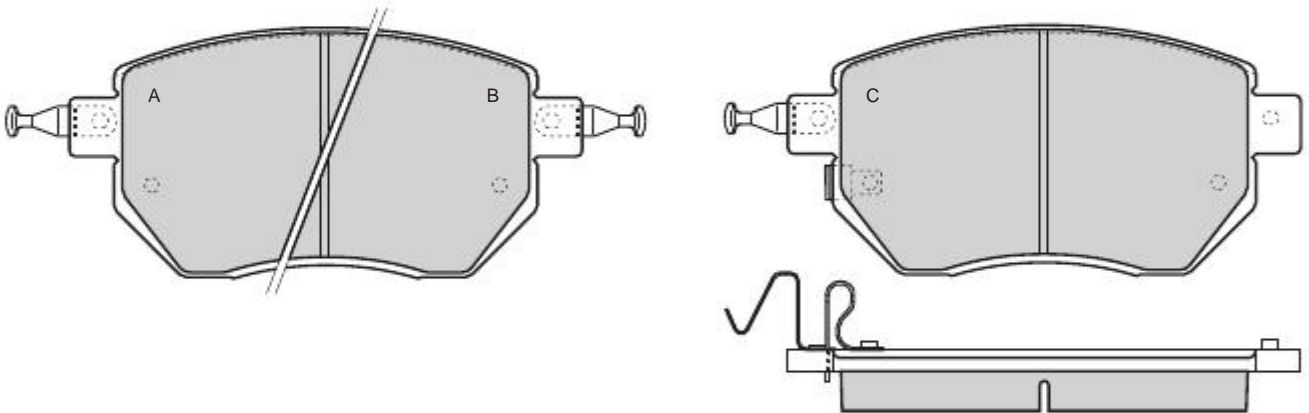



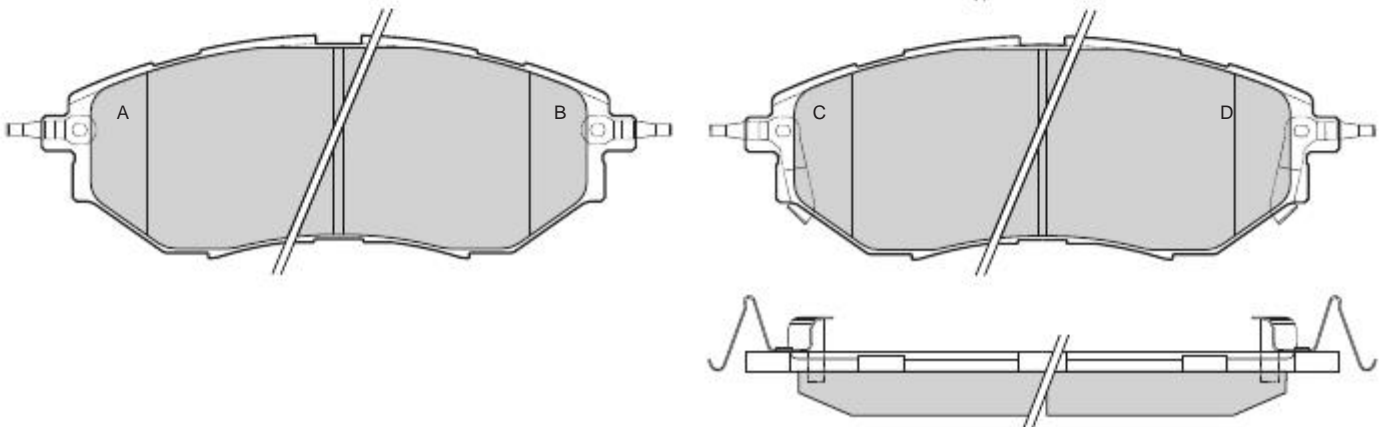

<b>1210</b>	NISSAN	TOKICO		135,6	66	15,5	1A 2B-1C		
-------------	--------	--------	--	-------	----	------	-------------	--	--



<b>1211</b>	SUBARU	AKEBONO		157	63,5	17,2	1A-1B 1C-1D		
-------------	--------	---------	--	-----	------	------	----------------	--	--

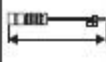

									
<b>1212</b>	HYUNDAI - KIA	MANDO	X	92,4	41	14	2A 1B-1C		

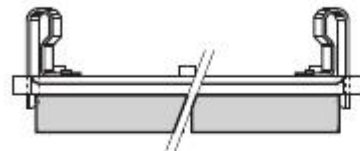
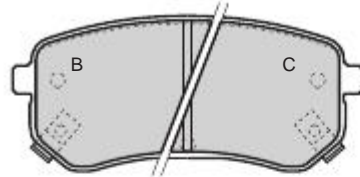
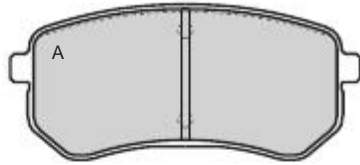



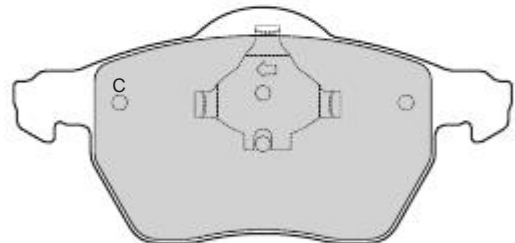
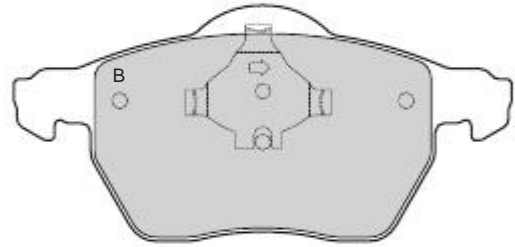



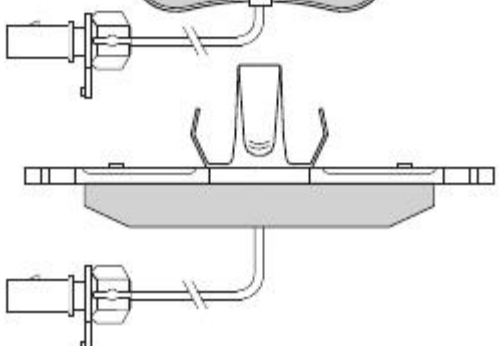
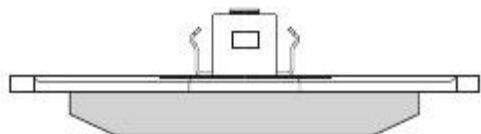
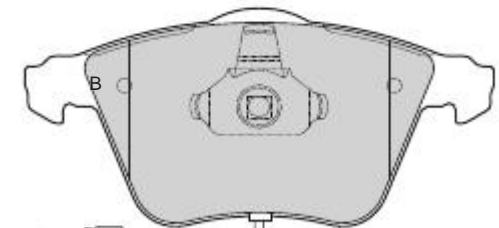

<b>1213</b>	VOLVO	ATE	X	156,4	74,2	18	2A 1B-1C		
-------------	-------	-----	---	-------	------	----	-------------	--	--



<b>1214</b>	AUDI	ATE	X	A 156,2 B 155	72,9	20,3	2A-2B	2	215
-------------	------	-----	---	------------------	------	------	-------	---	-----

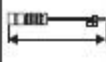

									
1215	CHRYSLER	KELSEY-HAYES	X	165	38,1	16	2A-2B		

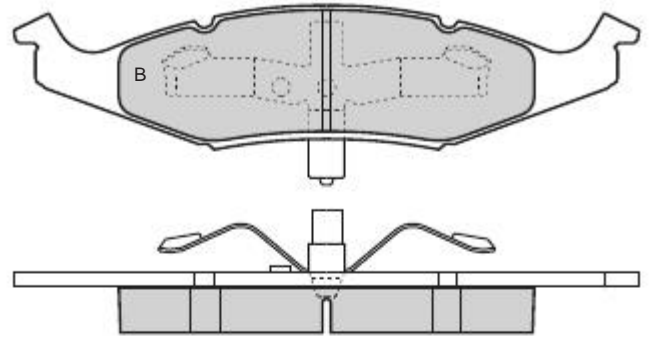
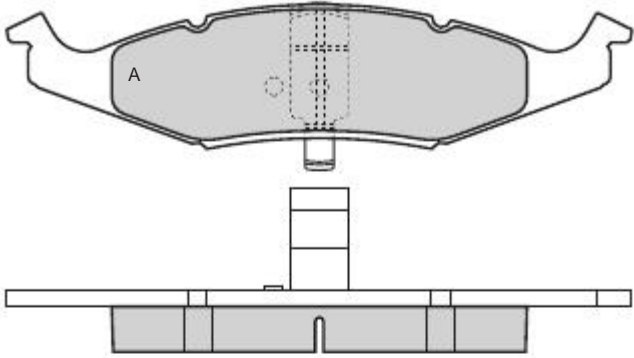



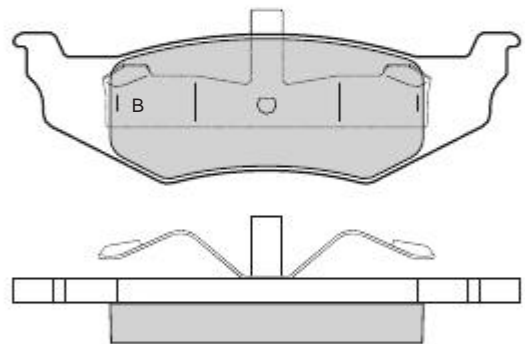
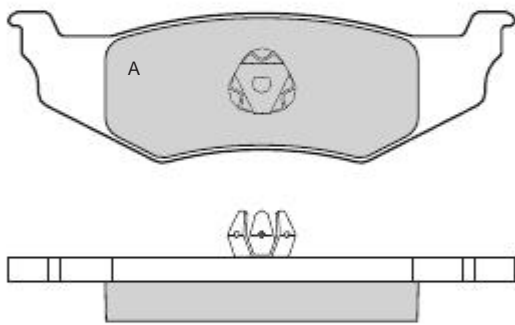



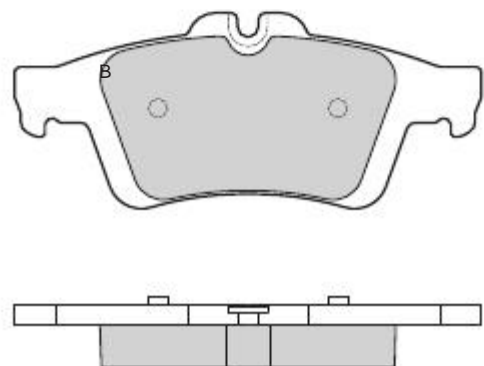
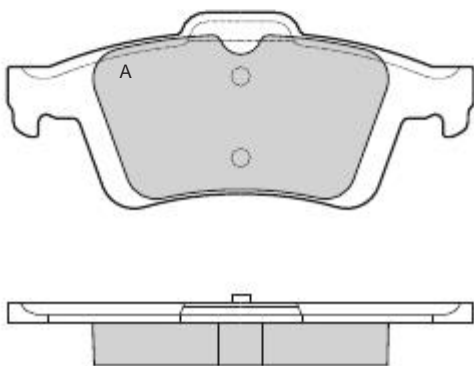

1216	CHRYSLER	KELSEY-HAYES	X	133,6	40	17	2A-2B		
------	----------	--------------	---	-------	----	----	-------	--	--



1217	MAZDA	ATE	X	123	51,8	16,4	2A-2B		
------	-------	-----	---	-----	------	------	-------	--	--

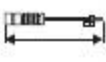

									
<b>1218</b>	SUBARU	AKEBONO	X	110,5	37,5	13,8	3A-1B		

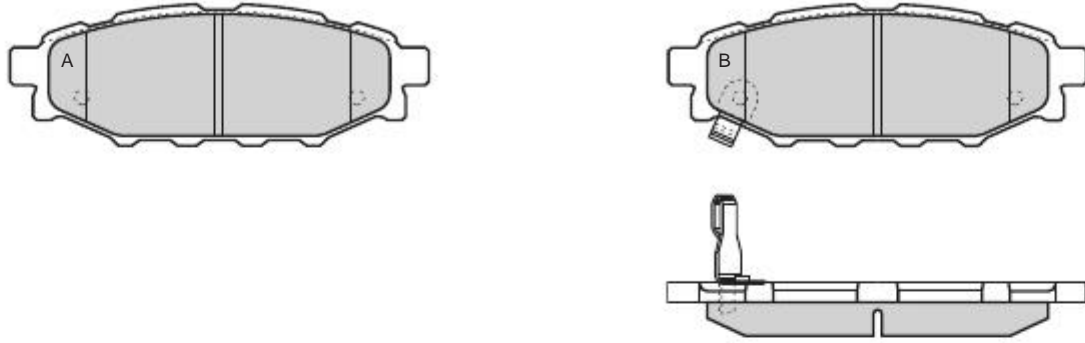



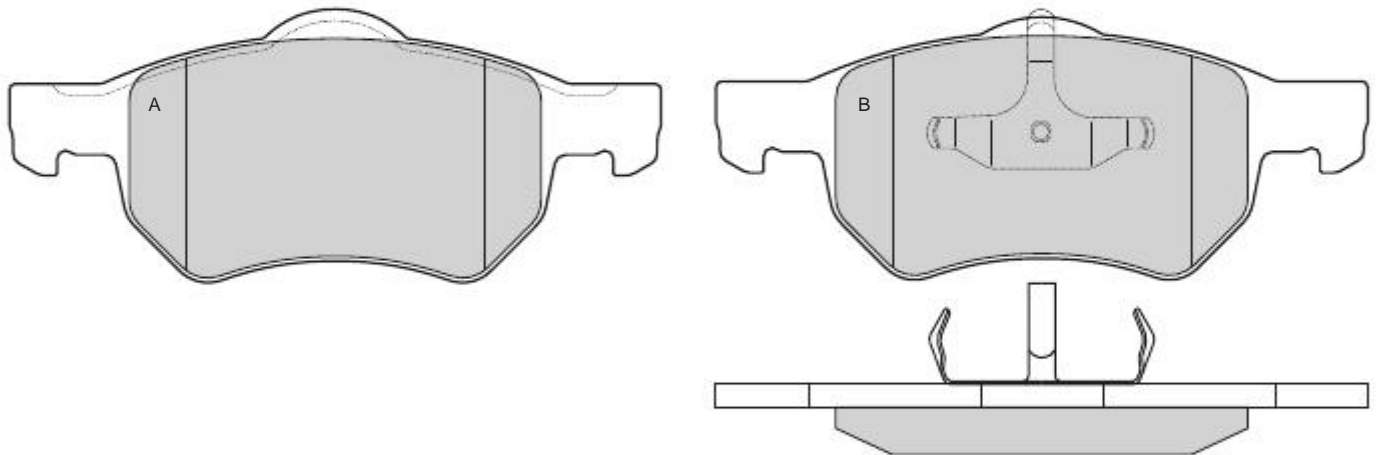



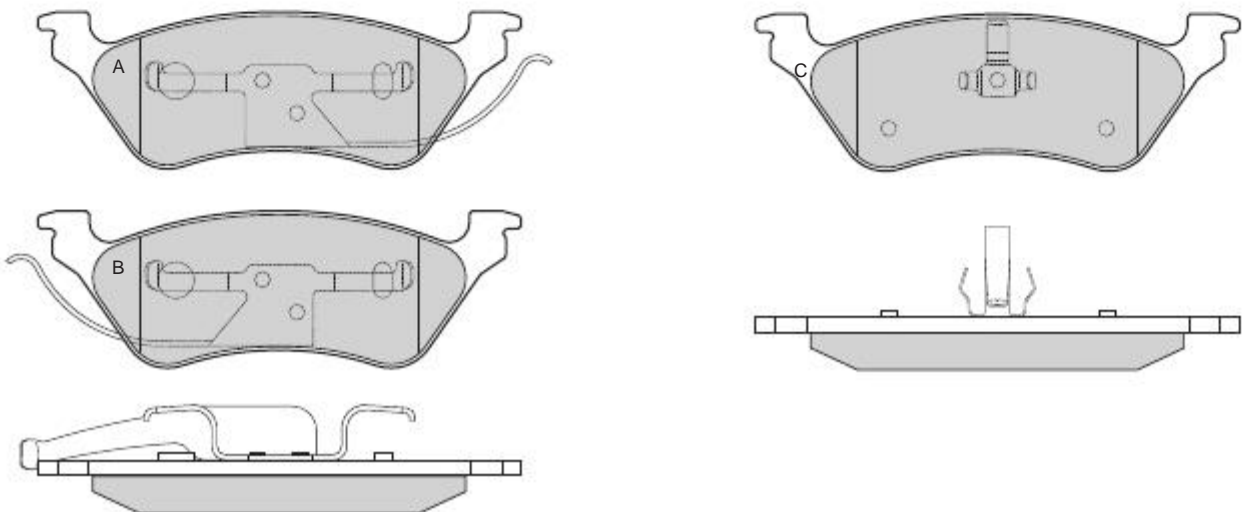



<b>1219</b>	CHRYSLER	ATE	X	172,2	A 72,5 B 69,3	18,6	2A-2B		
-------------	----------	-----	---	-------	------------------	------	-------	--	--



<b>1220</b>	CHRYSLER	KELSEY-HAYES	X	155,4	50,8	17	1A 1B-2C		
-------------	----------	--------------	---	-------	------	----	-------------	--	--



									
1221	CHRYSLER	LUCAS	X	146,6	59,7	18,5	2A-2B		

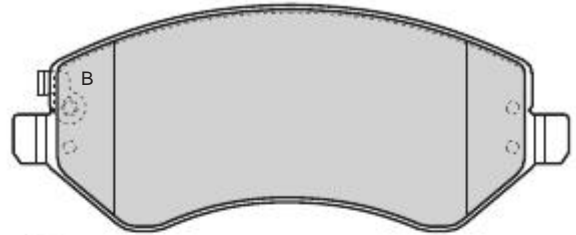
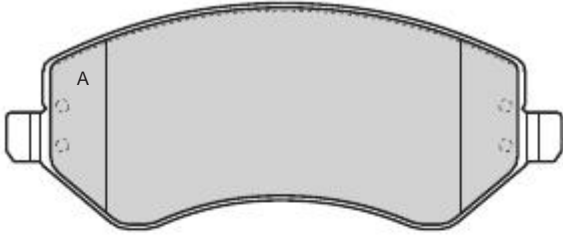



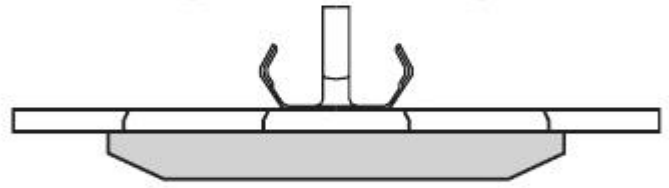
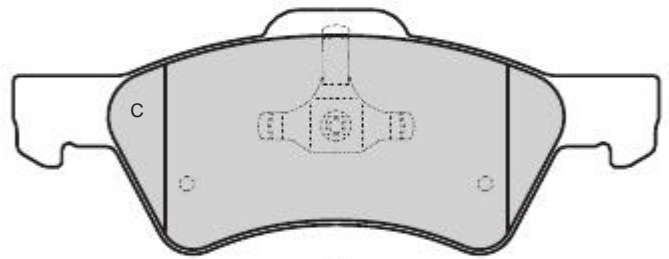
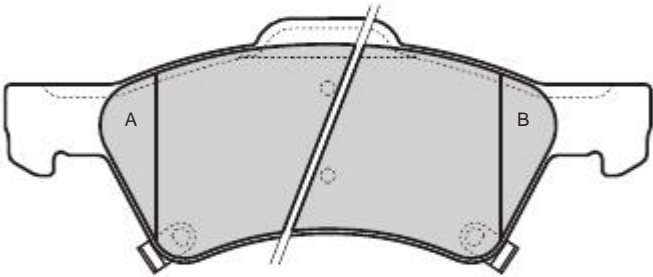



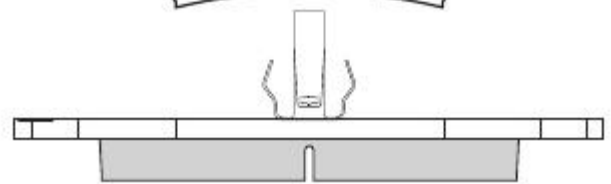
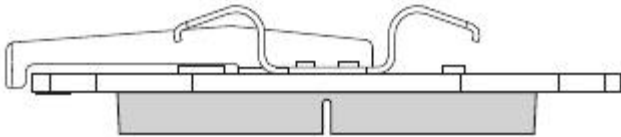
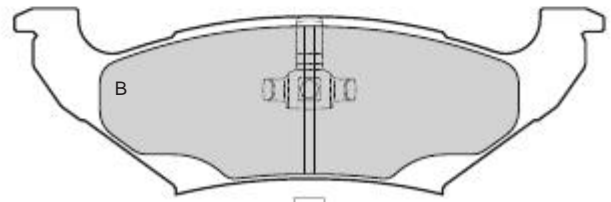
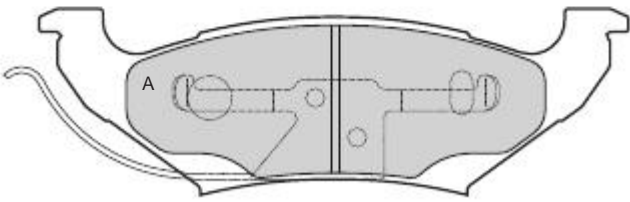



1222	CHRYSLER	ATE	X	172,6	65,5	18,8	1A 1B-2C		
------	----------	-----	---	-------	------	------	-------------	--	--



1223	CHRYSLER	KELSEY-HAYES	X	155,7	49,4	16	2A-2B		
------	----------	--------------	---	-------	------	----	-------	--	--



									
<b>1224</b>	JAGUAR	LUCAS	X	164,6	58	17,8	4		

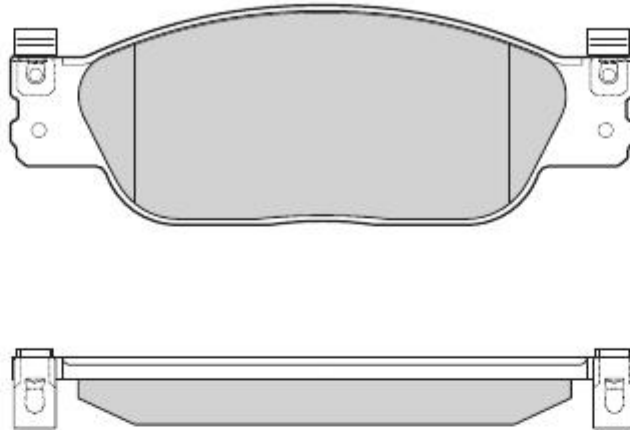



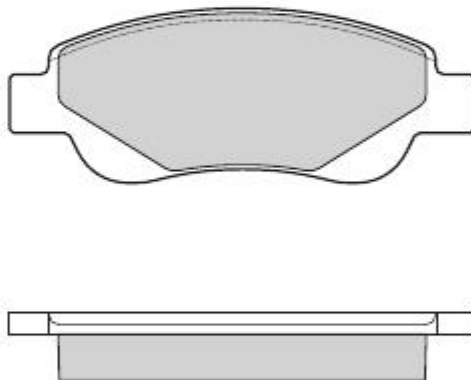



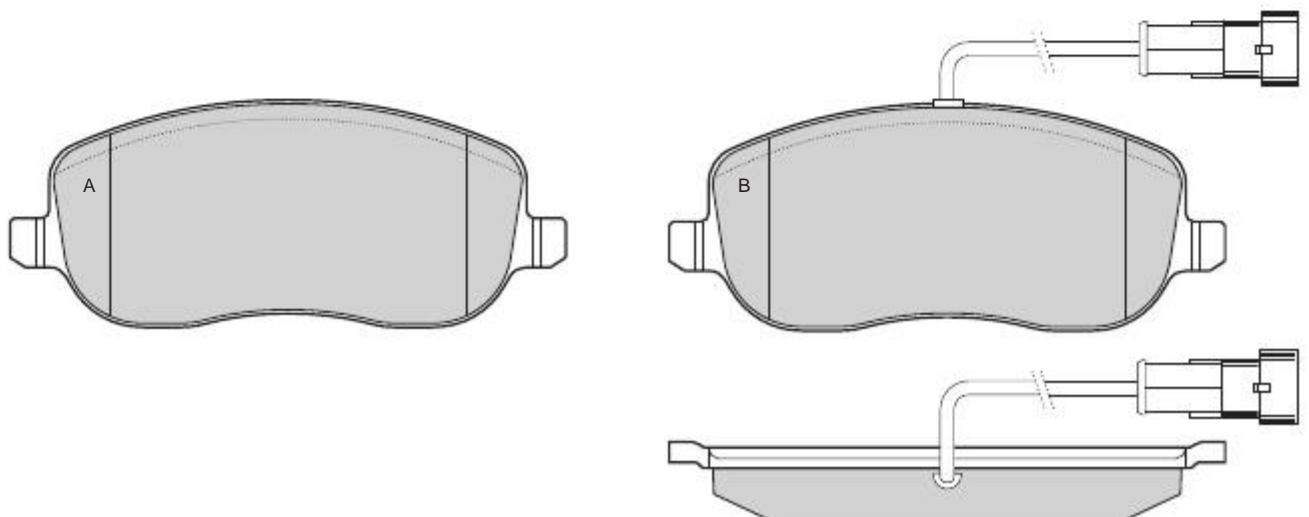

<b>1225</b>	CITROEN - PEUGEOT TOYOTA	BOSCH	X	122,8	46,2	17,6	4		
-------------	-----------------------------	-------	---	-------	------	------	---	--	--



<b>1226</b>	FIAT	LUCAS	X	146,7	60	19	3A-1B	1	190
-------------	------	-------	---	-------	----	----	-------	---	-----

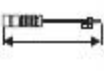

									
1227	FIAT	LUCAS	X	105,6	46,5	16,5	4		

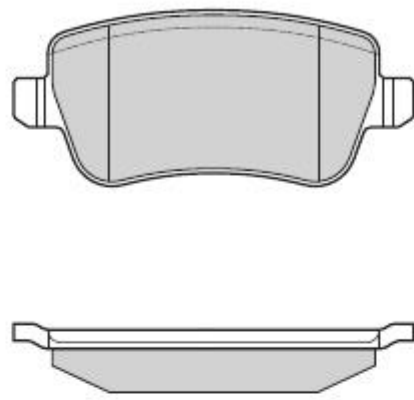



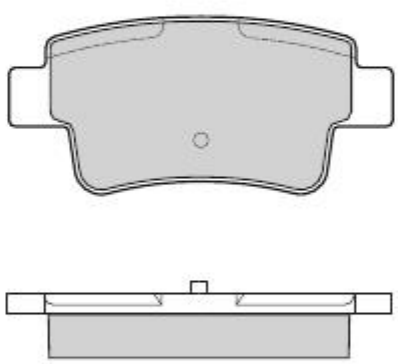



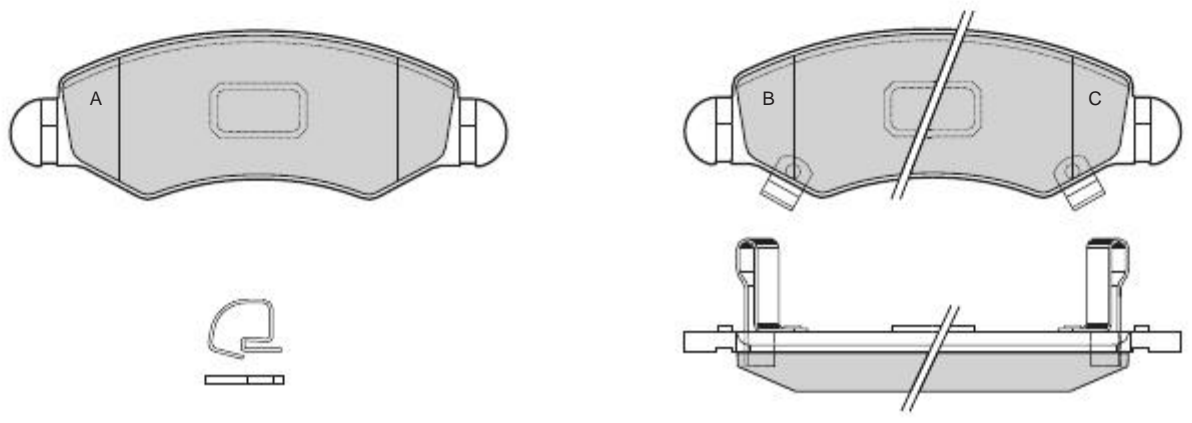



1228	FIAT	BOSCH	X	101,2	47	17	4		
------	------	-------	---	-------	----	----	---	--	--



1229	SUZUKI - SUBARU	BOSCH	X	131	44,5	15,7	2A 1B-1C		
------	-----------------	-------	---	-----	------	------	-------------	--	--





									
1230	NISSAN	AKEBONO	X	164	57,1	17	2A 1B-1C		

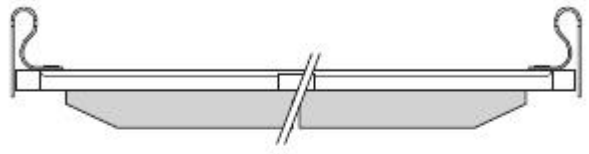
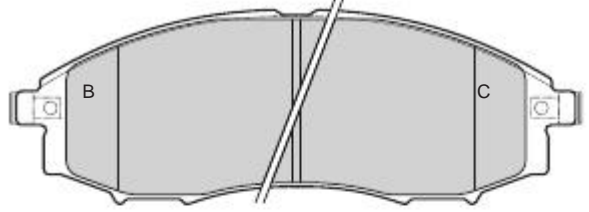
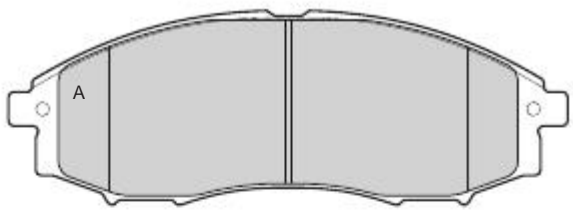



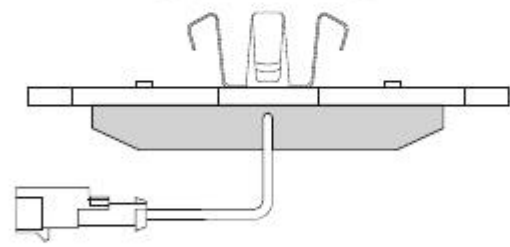
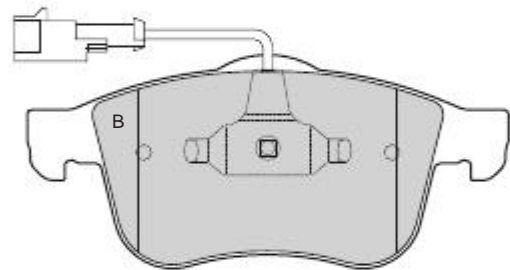



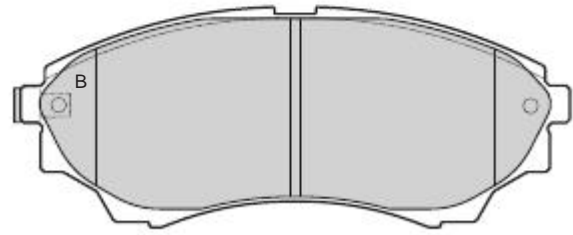
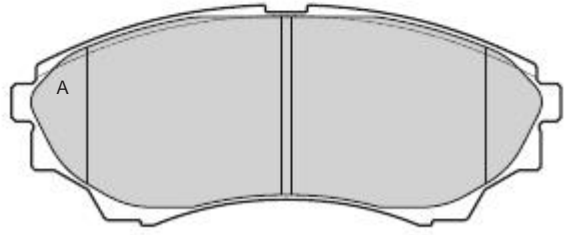

1231	ALFA ROMEO	ATE	X	A 156,3 B 155,1	A 71,5 B 68,9	20	2A-2B	1	230
------	------------	-----	---	--------------------	------------------	----	-------	---	-----



1232	FORD - MAZDA	TOKICO	X	145,1	58,4	16	3A-1B		
------	--------------	--------	---	-------	------	----	-------	--	--

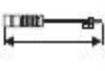

									
<b>1233</b>	MAZDA	AKEBONO	X	110,5	41,2	15,7	2A 1B-1C		

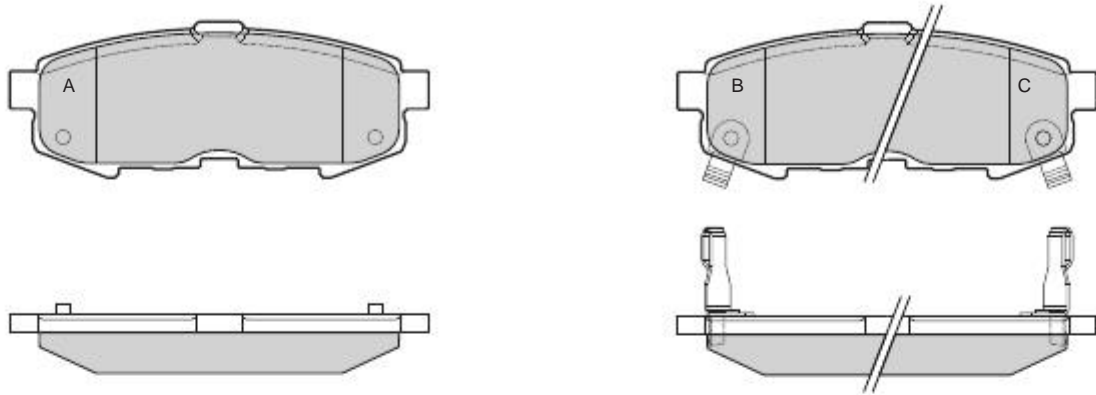



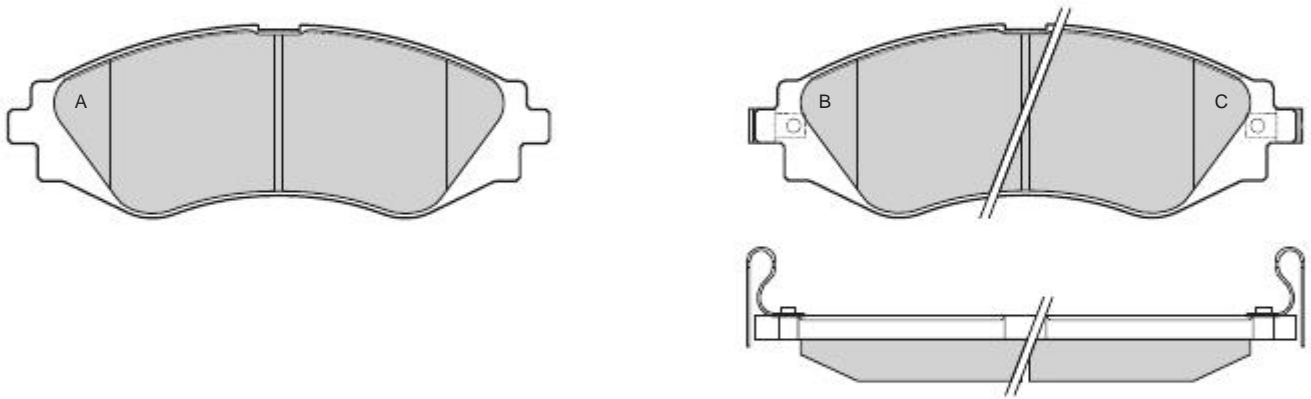



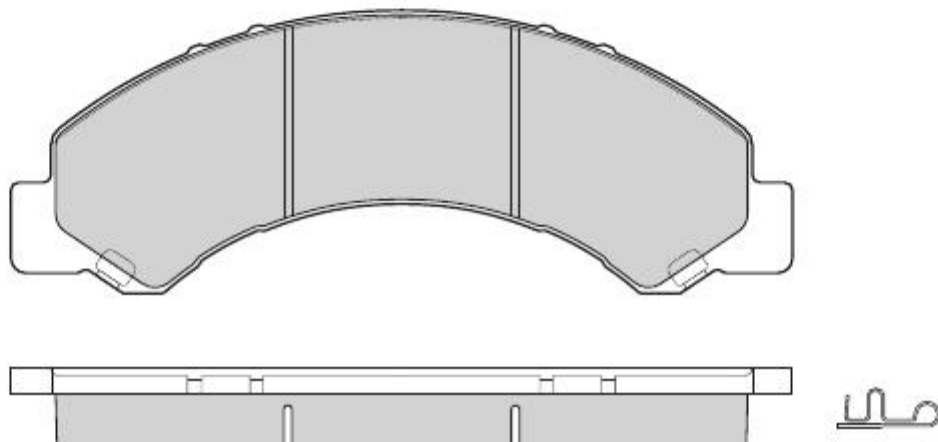

<b>1234</b>	DAEWOO	AKEBONO	X	143	51,1	17	2A 1B-1C	2	225
-------------	--------	---------	---	-----	------	----	-------------	---	-----



<b>1235</b>	ISUZU	AKEBONO	X	206,4	74,8	20	4		
-------------	-------	---------	---	-------	------	----	---	--	--

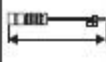

									
<b>1236</b>	ISUZU	AKEBONO	X	206,4	80	20	4		

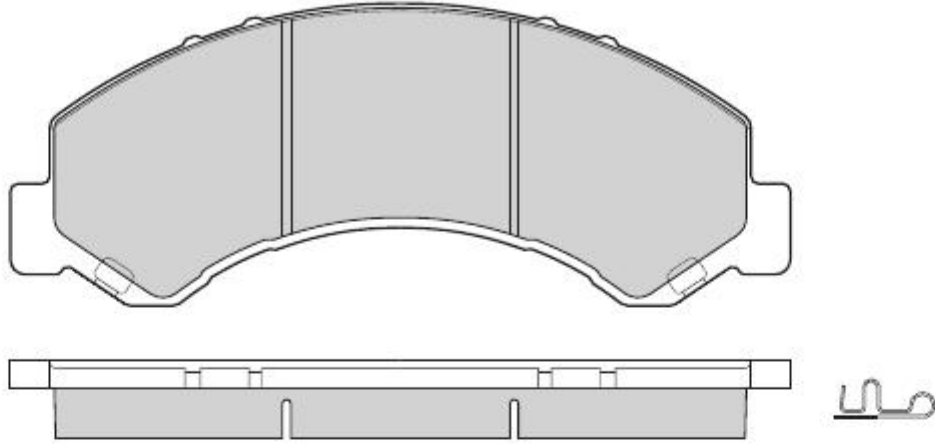



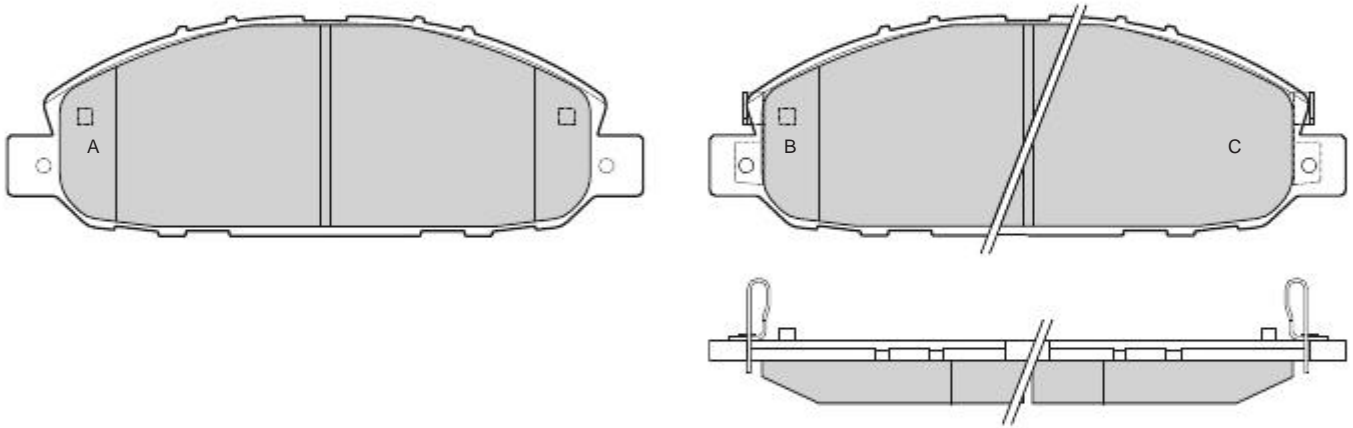



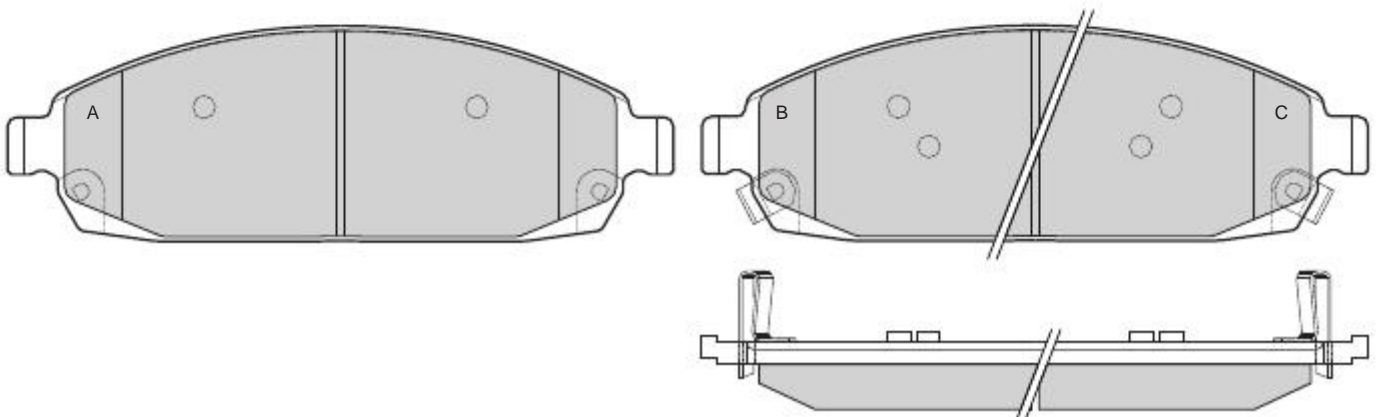



<b>1237</b>	NISSAN	AKEBONO	X	168,5	58	16,8	2A 1B-1C		
-------------	--------	---------	---	-------	----	------	-------------	--	--



<b>1238</b>	JEEP	AKEBONO	X	176	57	18	2A 1B-1C		
-------------	------	---------	---	-----	----	----	-------------	--	--



									
<b>1239</b>	JEEP	KELSEY-HAYES	X	142,2	A 53 B-C 49,2	17,4	2A 1B-1C		

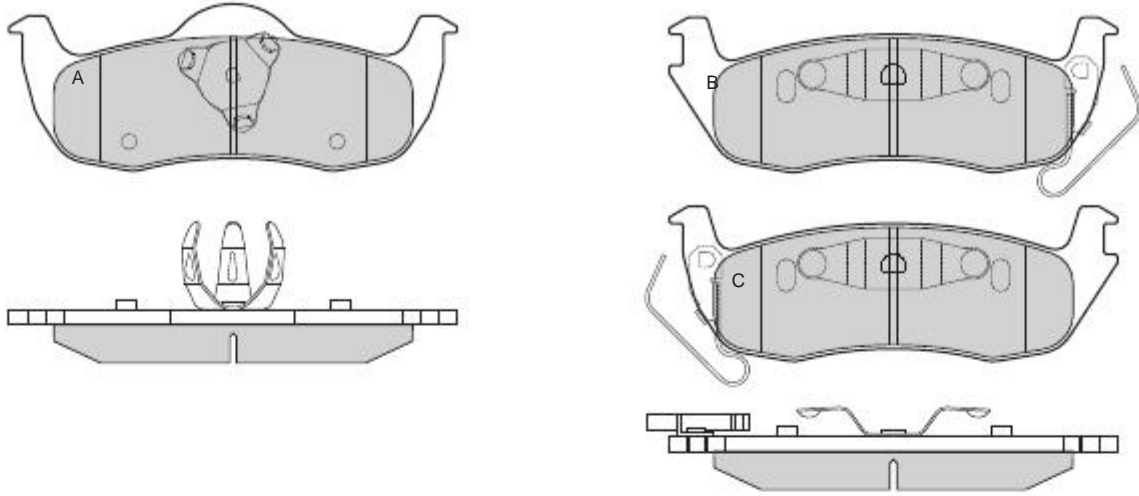



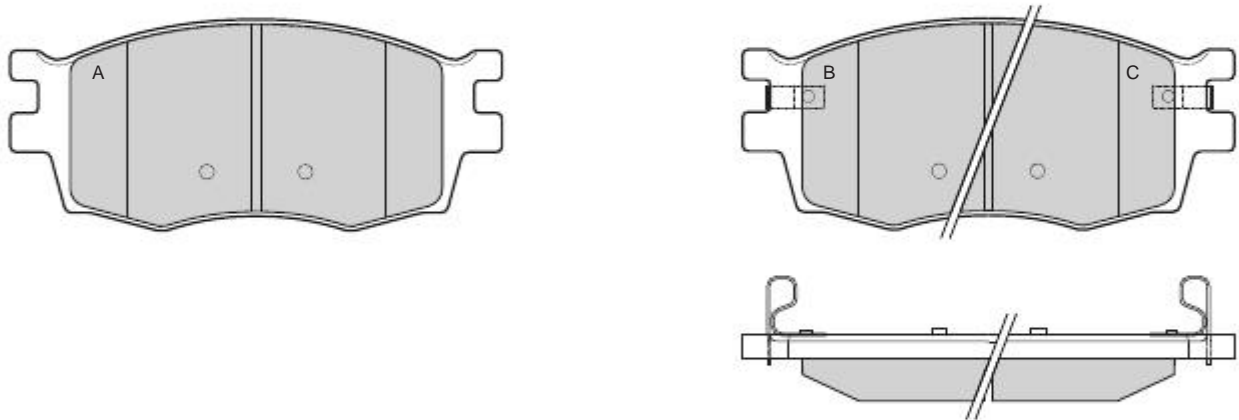



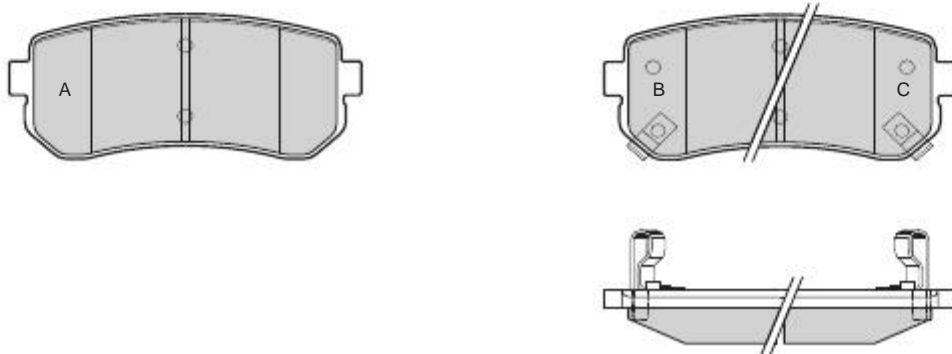

<b>1240</b>	KIA	MANDO	X	129,8	56	17,2	2A 1B-1C		
-------------	-----	-------	---	-------	----	------	-------------	--	--



<b>1241</b>	KIA	MANDO	X	92,9	41	15,1	2A 1B-1C		
-------------	-----	-------	---	------	----	------	-------------	--	--

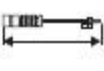

									
<b>1242</b>	FIAT - SUZUKI	LUCAS	X	131,5	59,9	15	3A-1B		

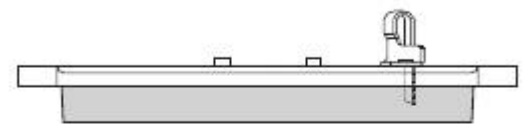
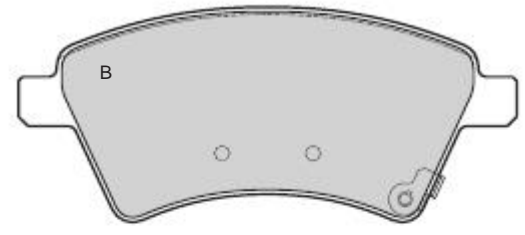
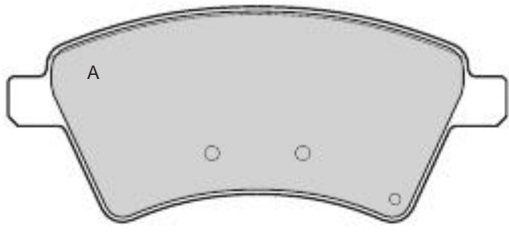



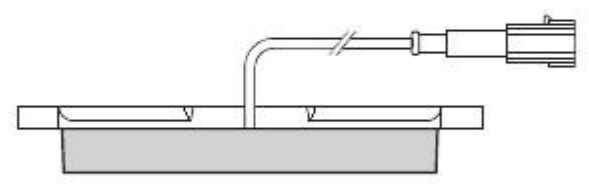
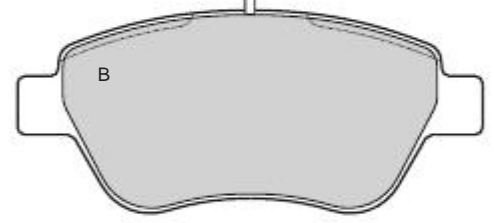
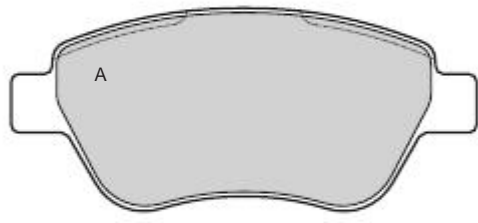



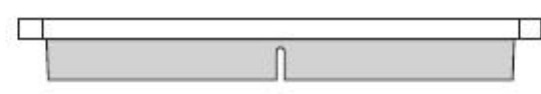
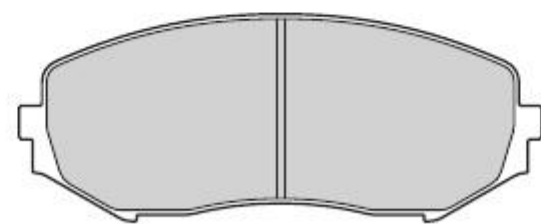

<b>1243</b>	FIAT - LANCIA	BOSCH	X	122,8	53,6	17	3A-1B	1	200
-------------	---------------	-------	---	-------	------	----	-------	---	-----



<b>1244</b>	SUZUKI	TOKICO	X	137,9	54,7	16,3	4		
-------------	--------	--------	---	-------	------	------	---	--	--

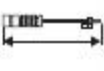

									
<b>1245</b>	HONDA	LUCAS	X	131,5	55,7	16,65	4		

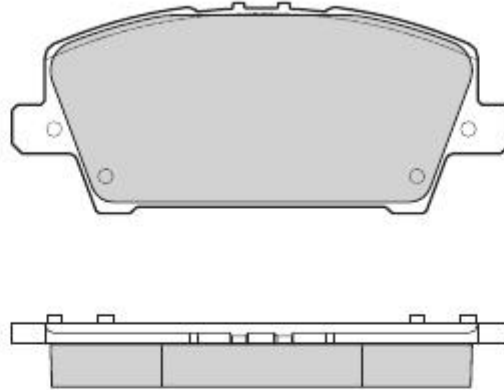



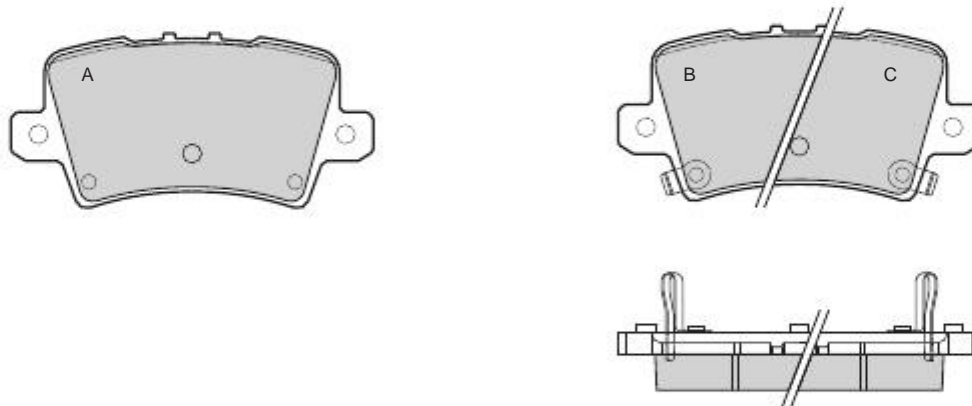



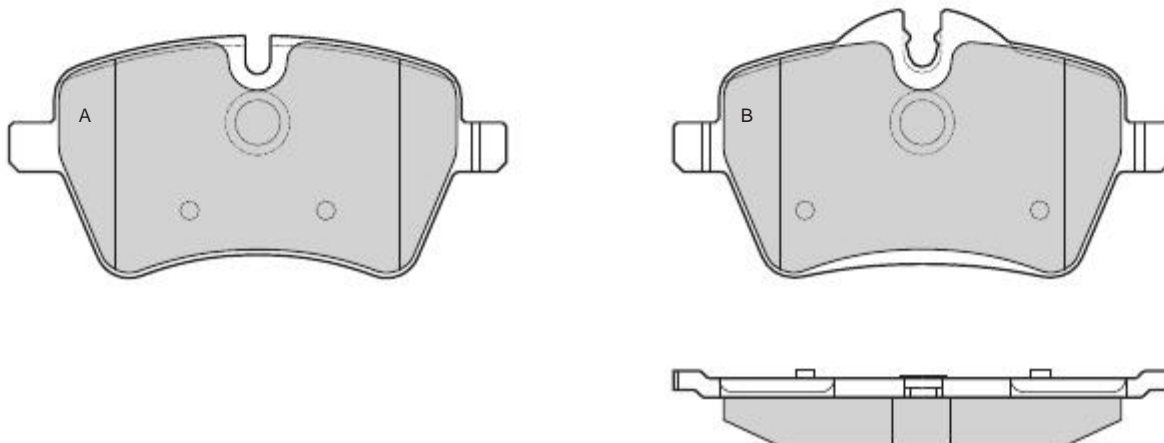



<b>1246</b>	HONDA	LUCAS	X	95,6	46,4	15	2A 1B-1C		
-------------	-------	-------	---	------	------	----	-------------	--	--



<b>1247</b>	MINI (BMW)	LUCAS	X	131,3	A 64 B 71,3	18	2A-2B		
-------------	------------	-------	---	-------	----------------	----	-------	--	--



									
<b>1248</b>	SUZUKI	GIRLING	X	116,3	52,4	17,3	3A-1B		

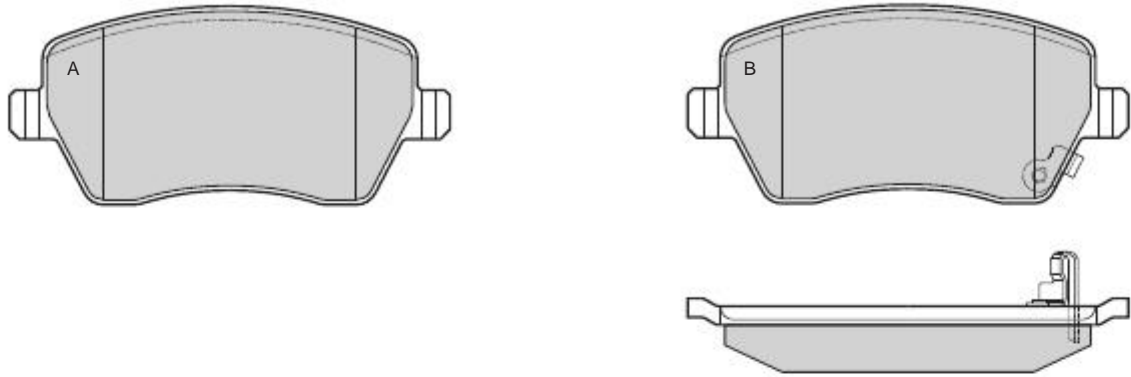



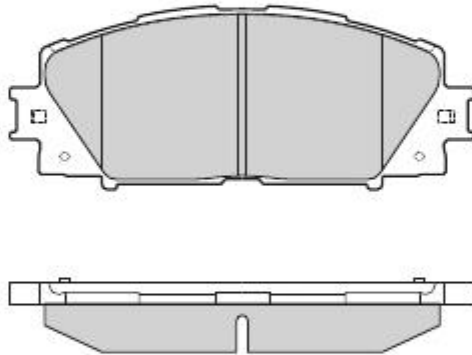



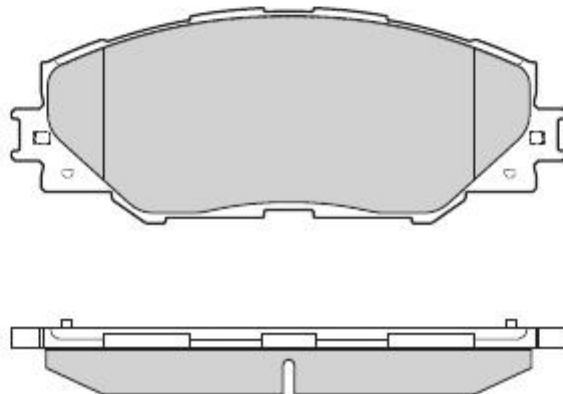



<b>1249</b>	TOYOTA	AKEBONO	X	122,6	49,7	18,2	4		
-------------	--------	---------	---	-------	------	------	---	--	--



<b>1250</b>	TOYOTA	AKEBONO	X	146,4	57	17,6	4		
-------------	--------	---------	---	-------	----	------	---	--	--



									
<b>1251</b>	TOYOTA	AKEBONO	X	139,1	56	17,5	4		

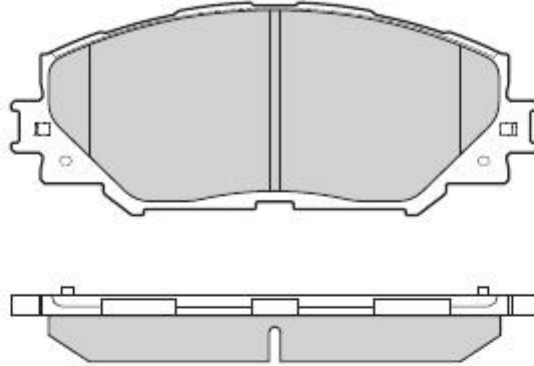



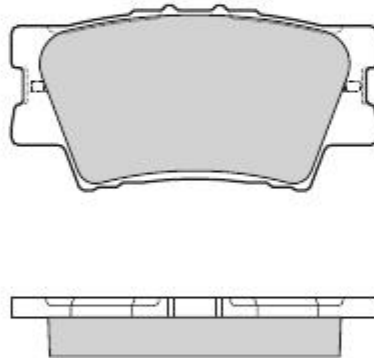



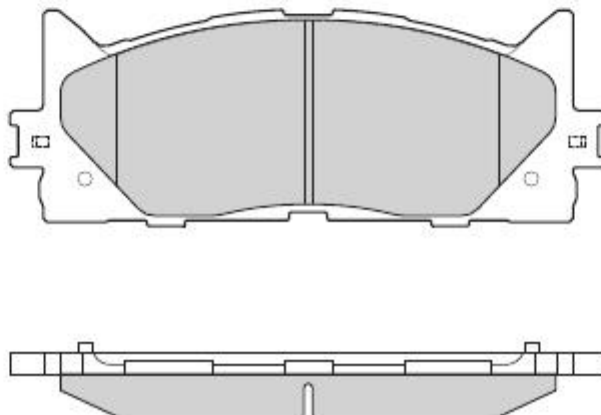

<b>1252</b>	TOYOTA	AKEBONO	X	96,5	49	15,4	4		
-------------	--------	---------	---	------	----	------	---	--	--



<b>1253</b>	TOYOTA	AKEBONO	X	157,5	57	17,6	4		
-------------	--------	---------	---	-------	----	------	---	--	--



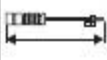

									
1254	LEXUS	AKEBONO	X	154,5	59,5	17,7	4		

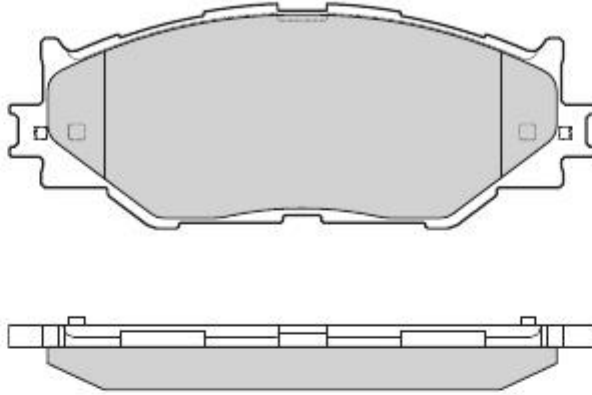



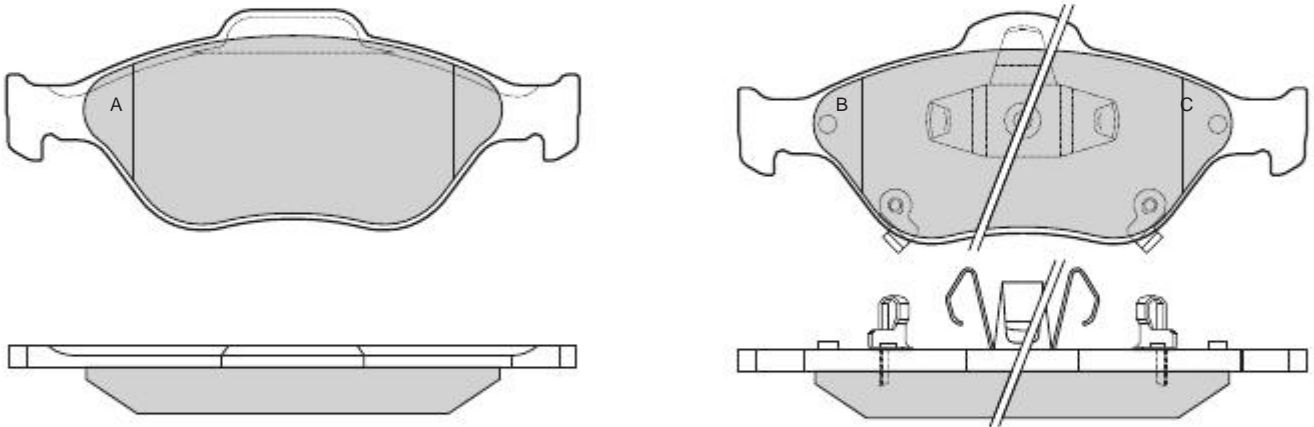



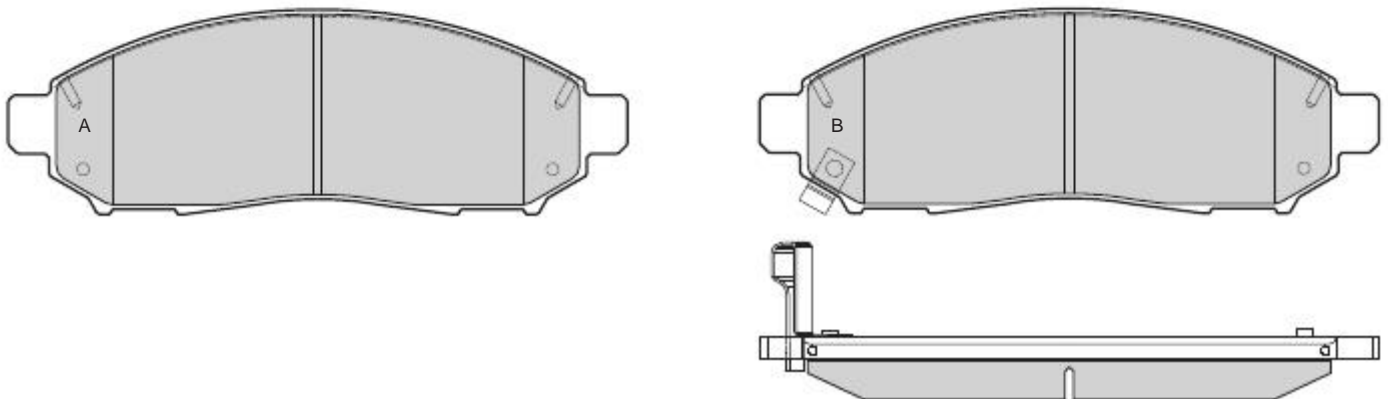

1255	TOYOTA	ATE	X	A 151,3 B 150,1	A 58,3 B 61	17,9	2A 1B-1C		
------	--------	-----	---	--------------------	----------------	------	-------------	--	--



1256	NISSAN	TOKICO	X	163,5	54,1	16,5	3A-1B		
------	--------	--------	---	-------	------	------	-------	--	--

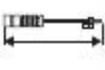

									
1257	NISSAN	TOKICO	X	110,7	41	15,7	3A-1B		

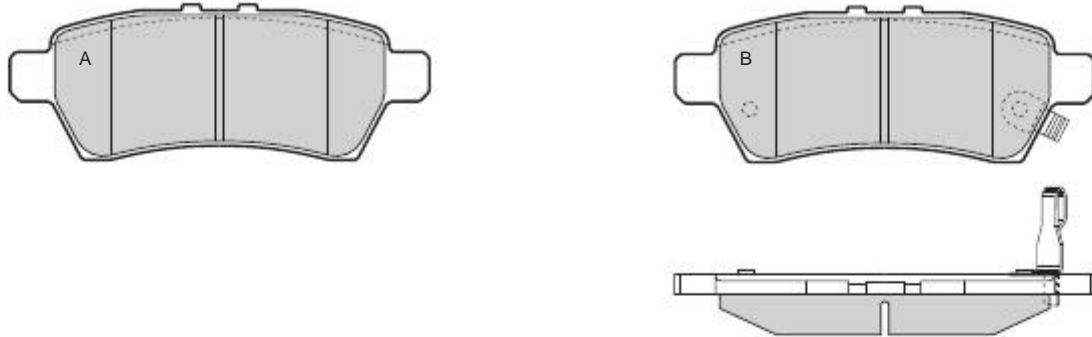



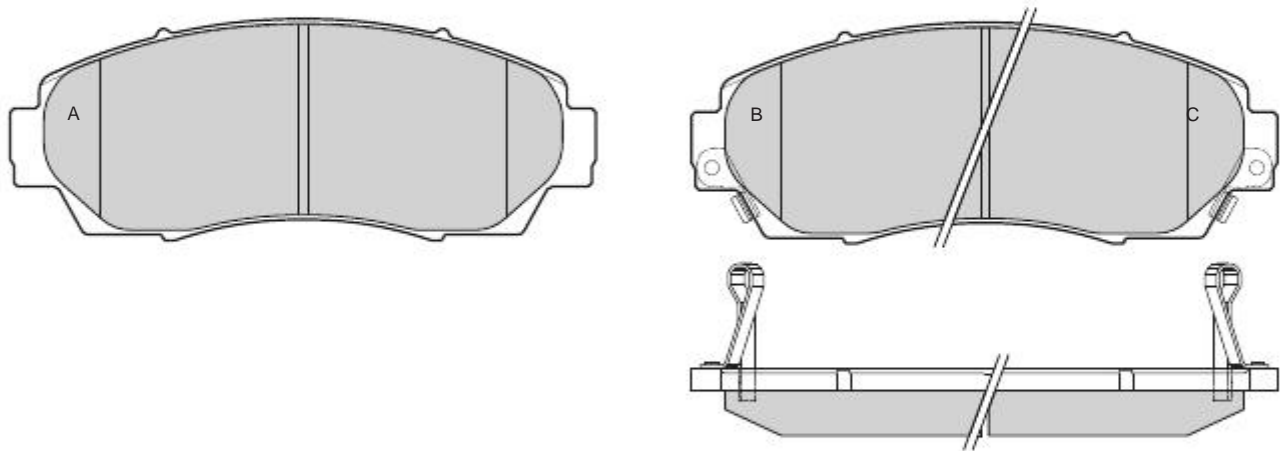



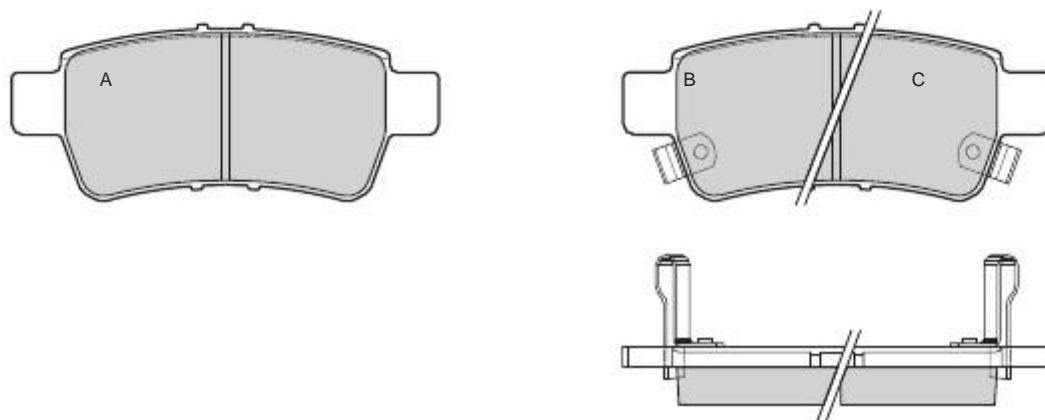



1258	HONDA	AKEBONO	X	154,8	58,5	18,0	2A 1B-1C		
------	-------	---------	---	-------	------	------	-------------	--	--



1259	HONDA	AKEBONO	X	112,8	46,7	15,5	2A 1B-1C		
------	-------	---------	---	-------	------	------	-------------	--	--



									
<b>1260</b>	MAZDA	SUMITOMO	X	122,9	58,3	14,4	4		

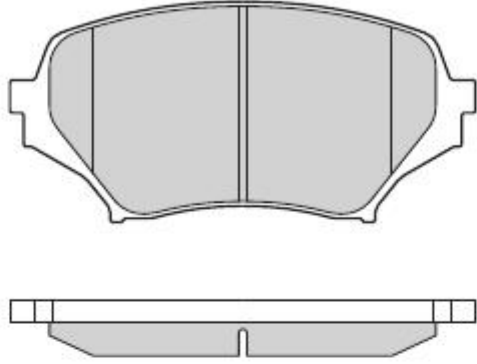



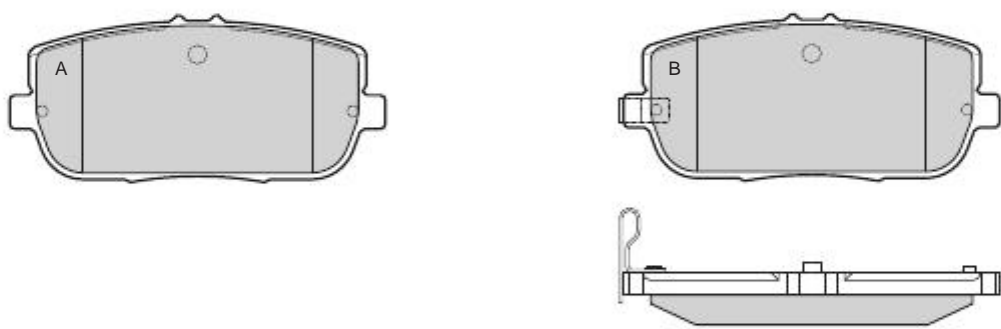



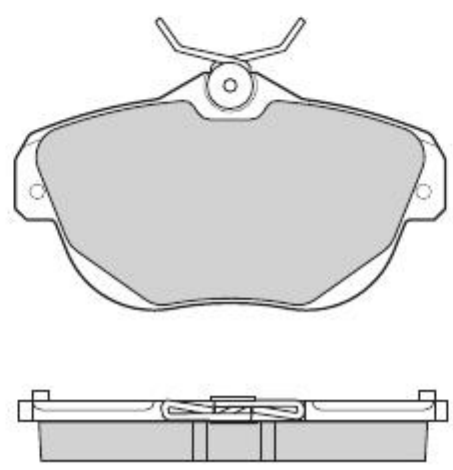

<b>1261</b>	MAZDA	SUMITOMO	X	99,2	45	13,8	3A-1B		
-------------	-------	----------	---	------	----	------	-------	--	--



<b>1262</b>	CITROEN	LUCAS	X	113,6	62,7	16,7	4		
-------------	---------	-------	---	-------	------	------	---	--	--

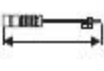

									
<b>1263</b>	BMW	ATE	X	123	58,1	17,3	2A-2B		

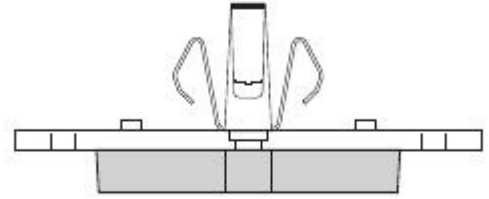
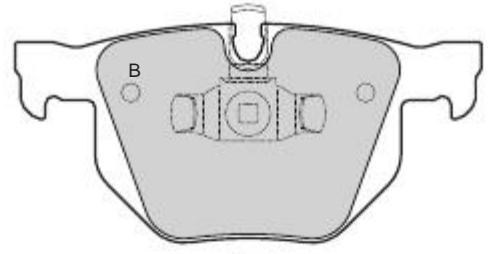
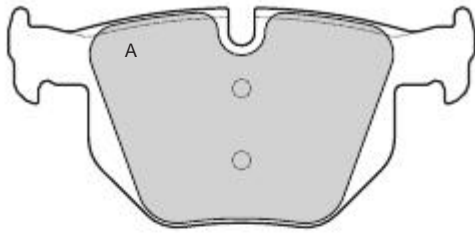



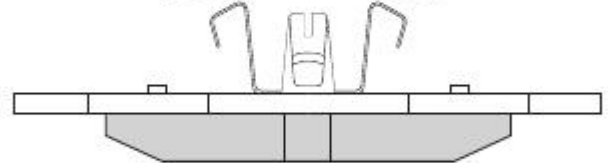
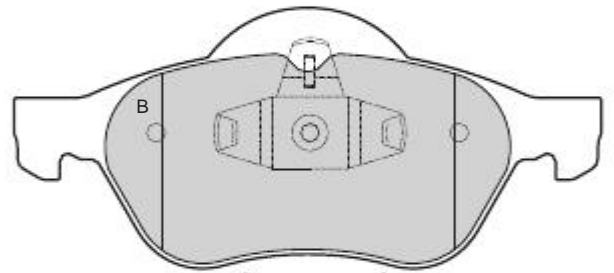
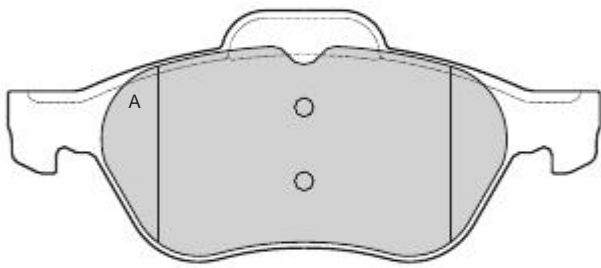



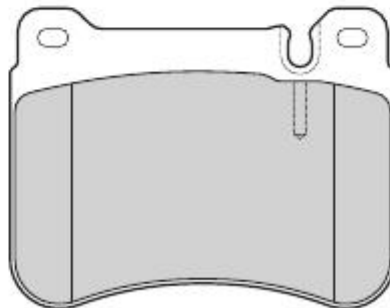



<b>1264</b>	RENAULT	ATE	X	A 156,3 B 155,1	A 66,4 B 68,8	18	2A-2B		
-------------	---------	-----	---	--------------------	------------------	----	-------	--	--



<b>1265</b>	MERCEDES	BREMBO	X	101,6	79,3	16,5	4		
-------------	----------	--------	---	-------	------	------	---	--	--



									
<b>1266</b>	FORD	BOSCH	X	101,9	50,6	16,3	4		

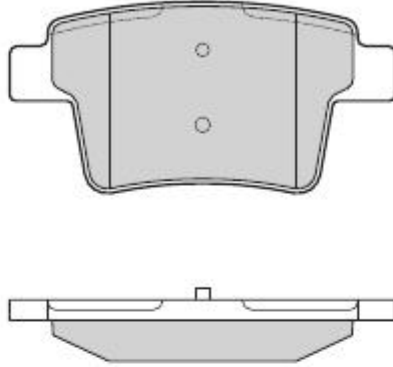



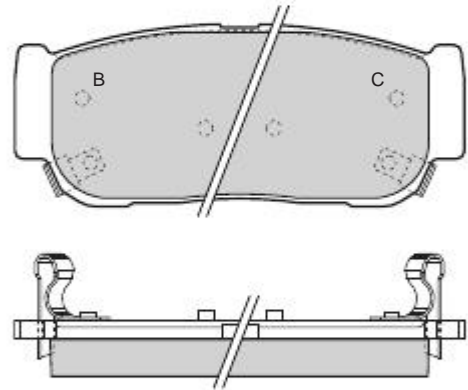
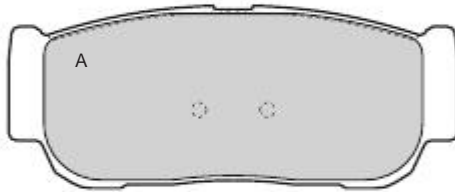



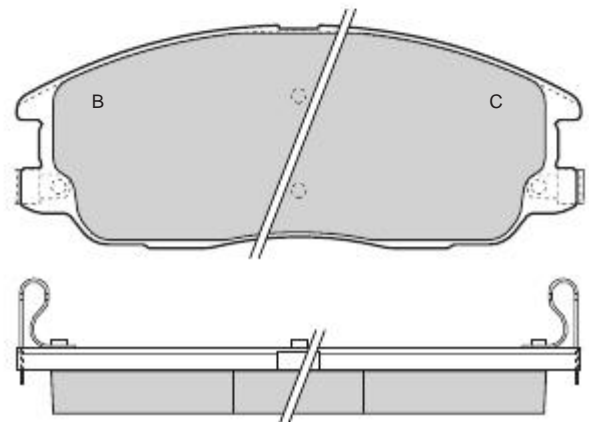

<b>1267</b>	KIA	MANDO	X	118,6	48,3	14,8	2A 1B-1C		
-------------	-----	-------	---	-------	------	------	-------------	--	--



<b>1268</b>	KIA	MANDO	X	149	59	17,3	2A 1B-1C		
-------------	-----	-------	---	-----	----	------	-------------	--	--

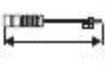

									
1269	JEEP	AKEBONO	X	157,6	60,2	19,3	4		

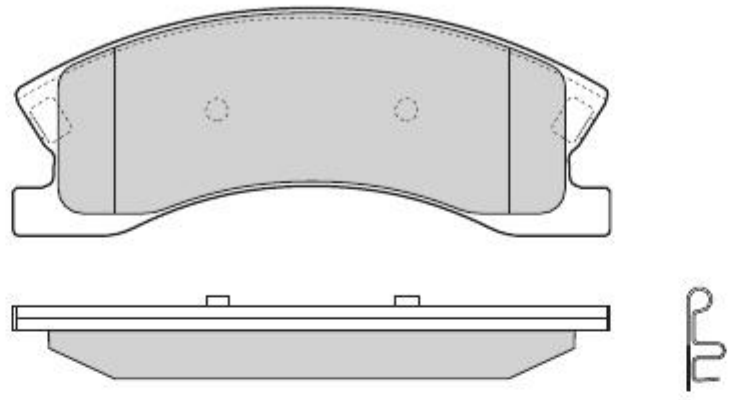



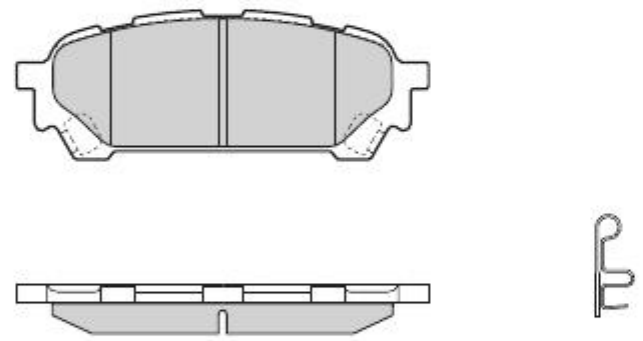



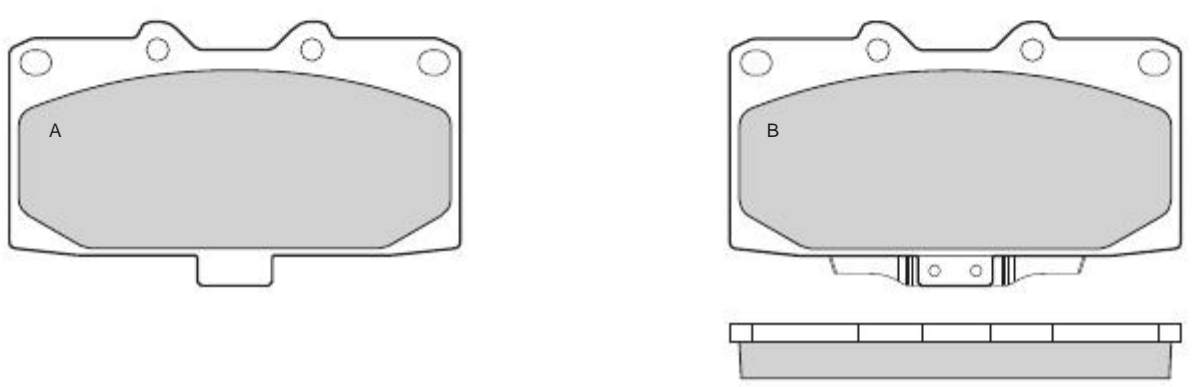



1270	SAAB - SUBARU	AKEBONO	X	108,7	39,5	13	4		
------	---------------	---------	---	-------	------	----	---	--	--



1271	NISSAN - SUBARU	SUMITOMO	X	119,2	69,7	14,2	2A-2B		
------	-----------------	----------	---	-------	------	------	-------	--	--



									
1272	TOYOTA	ADVICS	X	146,5	52,9	16,3	2A 1B-1C		

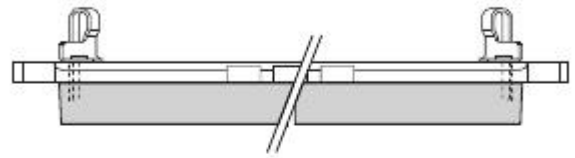
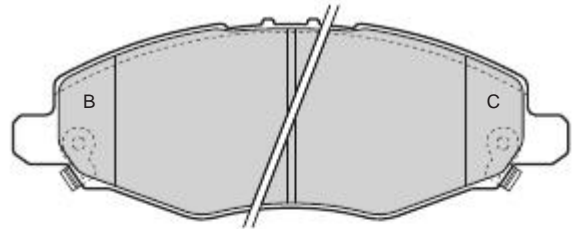
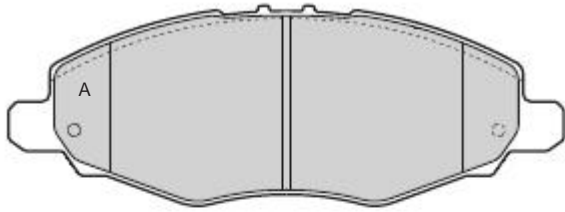



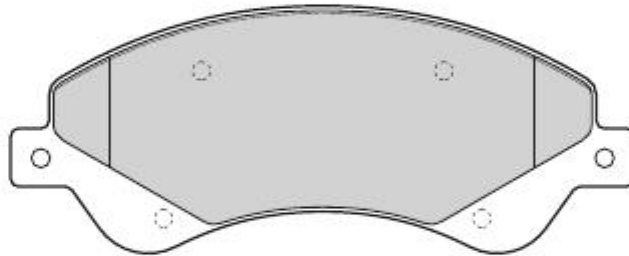



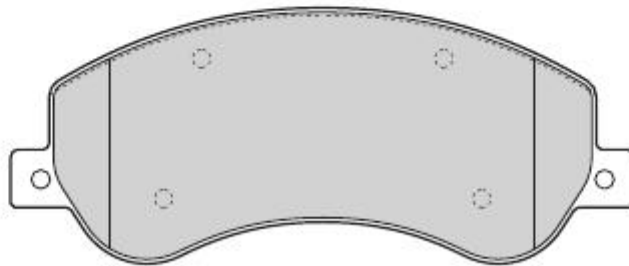



1273	FORD	BOSCH	X	164,7	65,4	17,2	4		
------	------	-------	---	-------	------	------	---	--	--



1274	FORD	BOSCH	X	164,7	66,8	17,2	4		
------	------	-------	---	-------	------	------	---	--	--



									
<b>1275</b>	FORD	BOSCH	X	122,8	53,9	17,5	4		

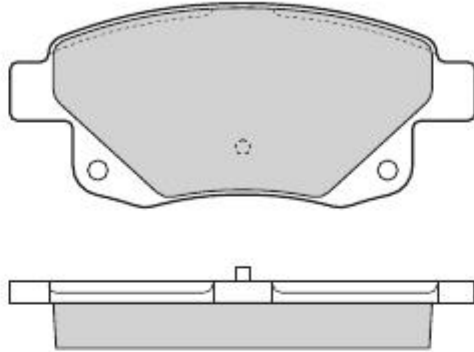



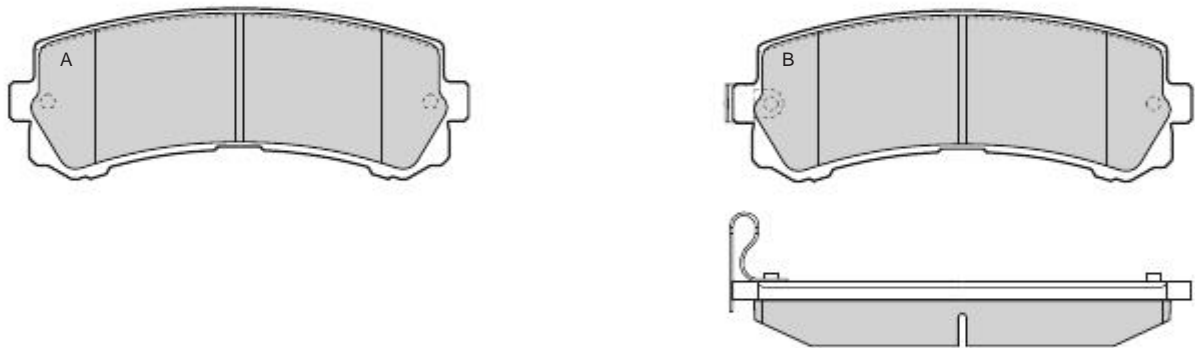



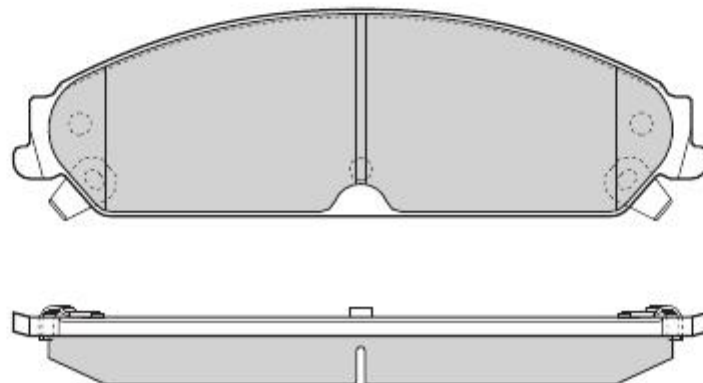

<b>1276</b>	NISSAN		X	121,1	45,5	17	2A-2B		
-------------	--------	--	---	-------	------	----	-------	--	--



<b>1277</b>	CHRYSLER - LANCIA	BOSCH	X	183,3	54,7	17,8	4		
-------------	-------------------	-------	---	-------	------	------	---	--	--



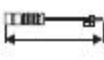

									
1278	CHRYSLER - LANCIA	BOSCH	X	101,3	57,4	17,8	4		

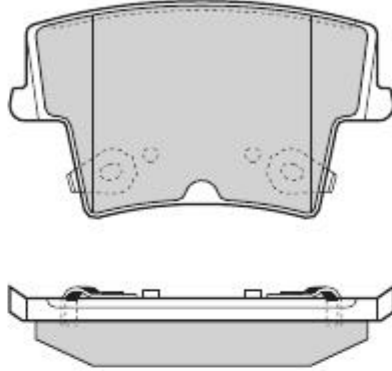



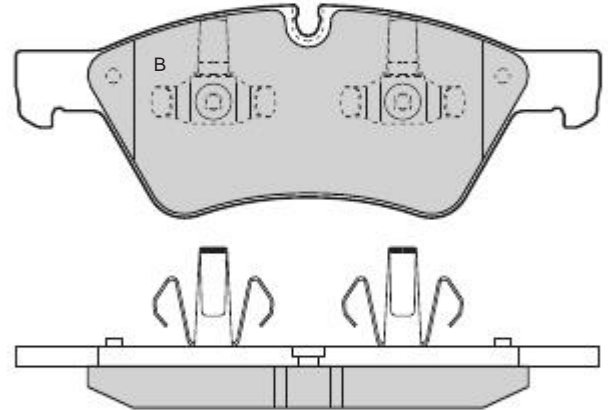
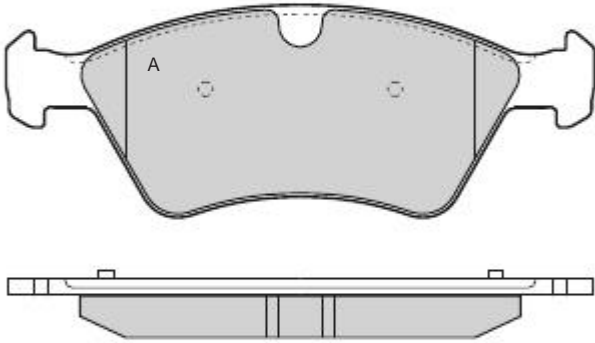



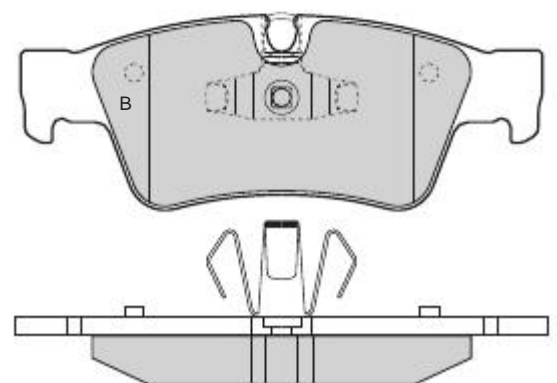
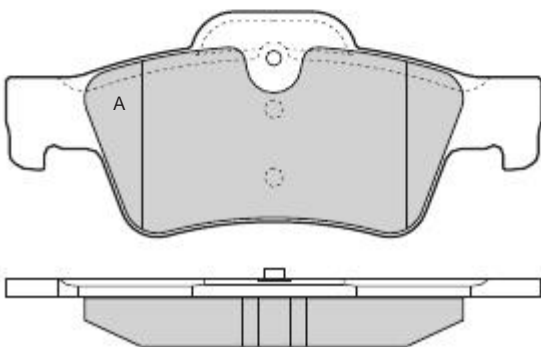

1279	MERCEDES	ATE	X	A 194,3 B 193	70,2	20,3	2A-2B		
------	----------	-----	---	------------------	------	------	-------	--	--



1280	MERCEDES	ATE	X	A 141,5 B 140,5	A 59,5 B 51,9	17,5	2A-2B		
------	----------	-----	---	--------------------	------------------	------	-------	--	--

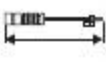

									
1281	HYUNDAI - KIA - SSANGYON	MANDO	X	148,7	60,8	16,4	2A 1B-1C		

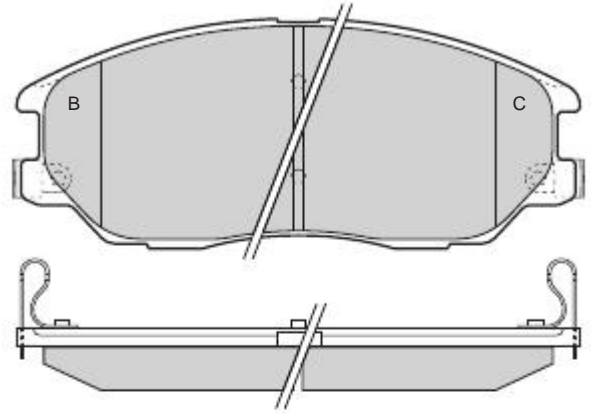
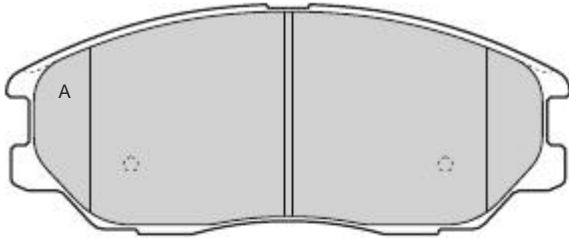



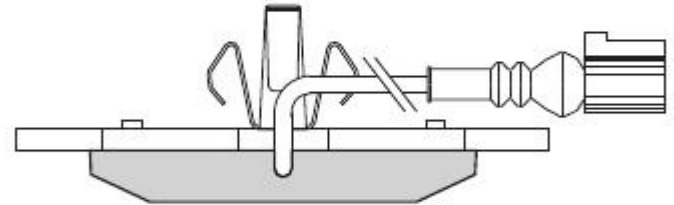
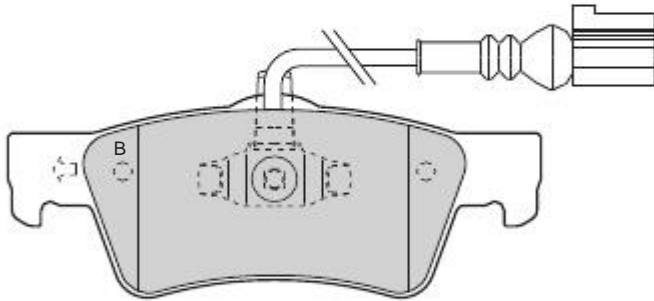
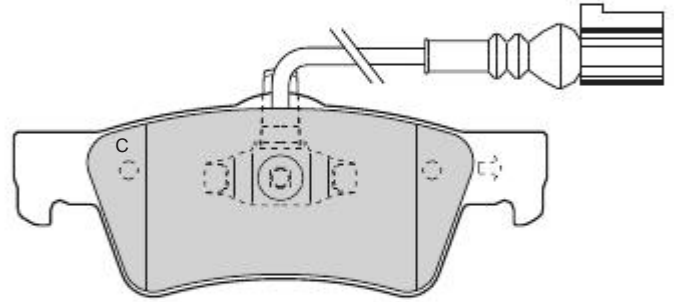
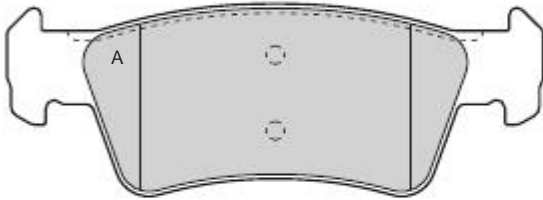



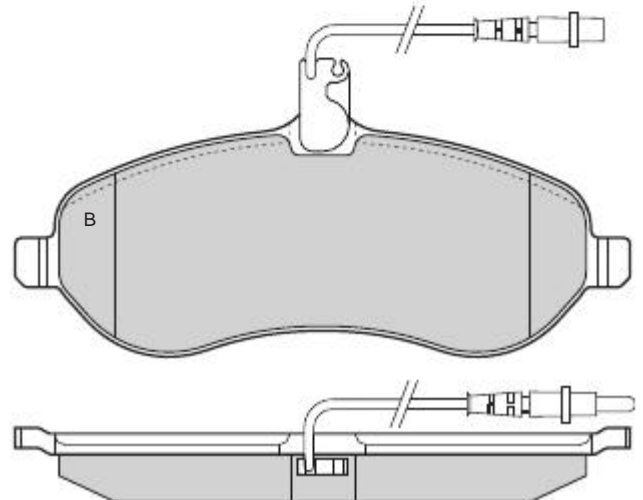
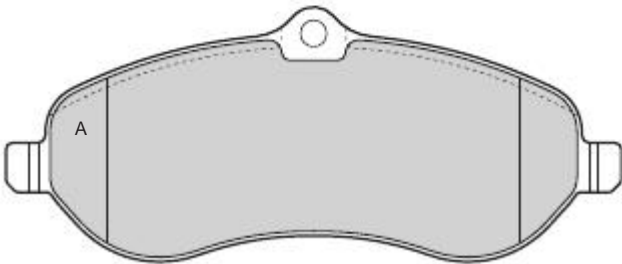



1282	VOLKSWAGEN	ATE	X	A 141,4 B-C 140,6	A 50,8 B-C 53,8	19,1	2A-1B 1C	2	240
------	------------	-----	---	----------------------	--------------------	------	-------------	---	-----



1283	CITROEN - FIAT - PEUGEOT	LUCAS	X	162,3	67,2	18,1	3A-1B	1	350
------	--------------------------	-------	---	-------	------	------	-------	---	-----



									
<b>1284</b>	CITROEN - FIAT - PEUGEOT	LUCAS	X	113,3	58,5	17	4		

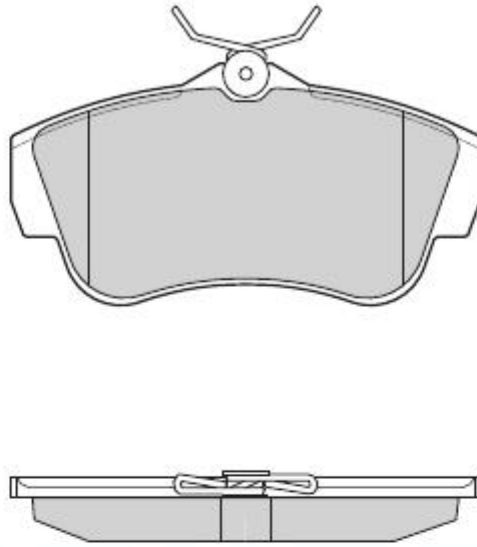



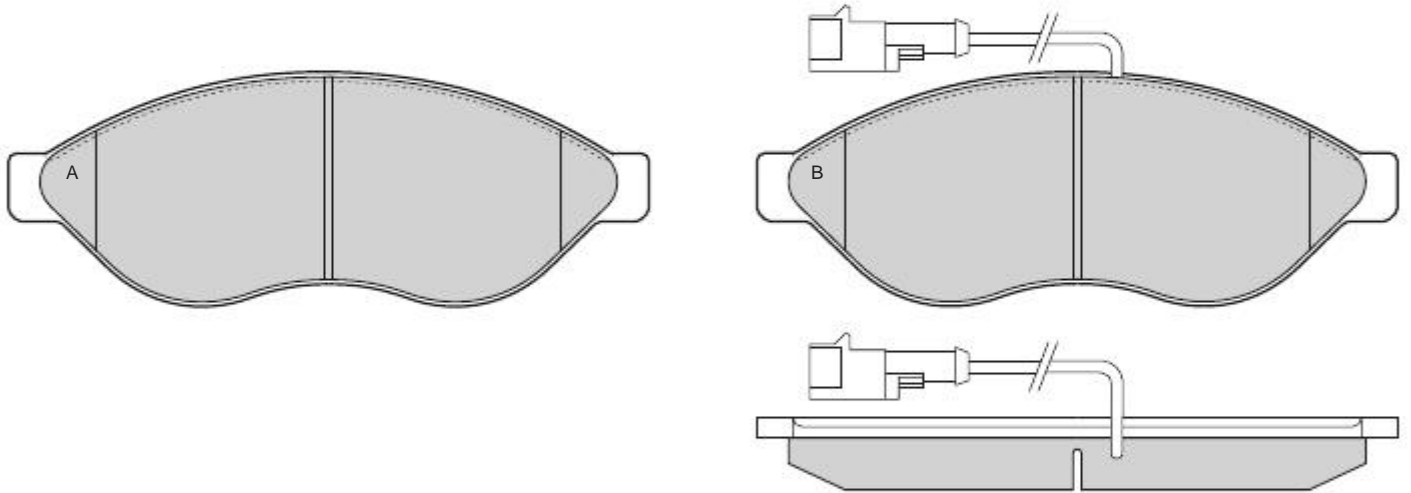



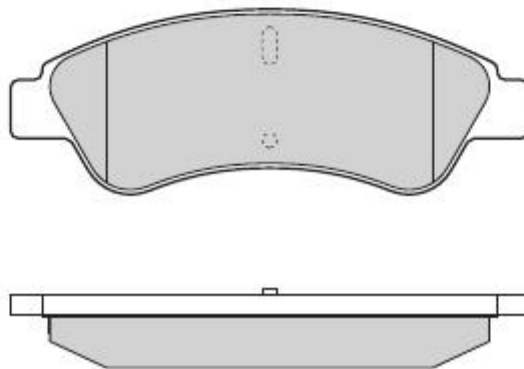

<b>1285</b>	CITROEN - FIAT - PEUGEOT	BREMBO	X	169,1	61,5	19,2	3A-1B	1	155
-------------	--------------------------	--------	---	-------	------	------	-------	---	-----



<b>1286</b>	CITROEN - FIAT - PEUGEOT	BOSCH	X	136,8	48,9	19	4		
-------------	--------------------------	-------	---	-------	------	----	---	--	--

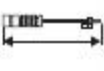

									
1287	LAND ROVER	ATE	X	A 156,2 B 154,9	73,2	19,4	2A-2B		

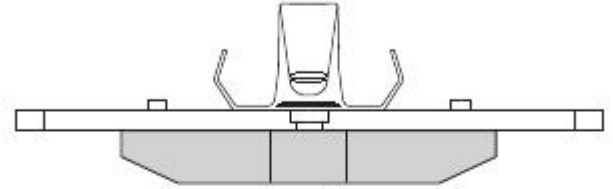
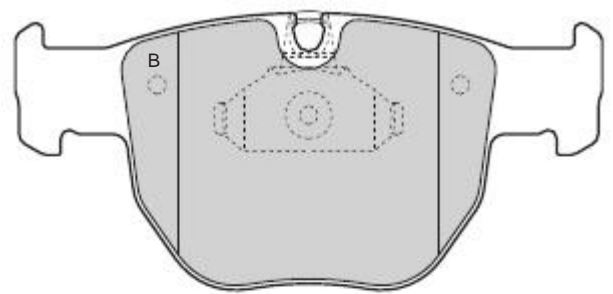
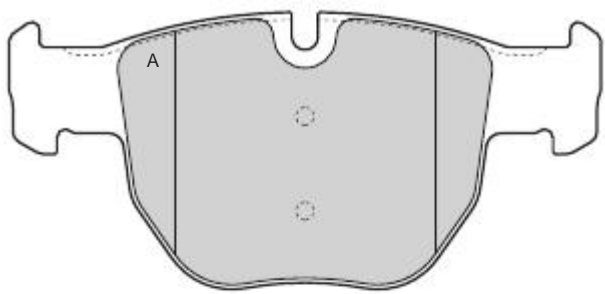



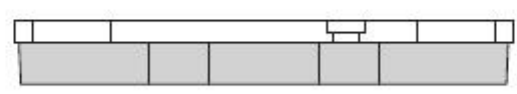
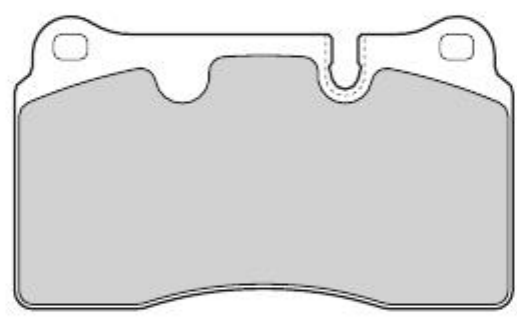



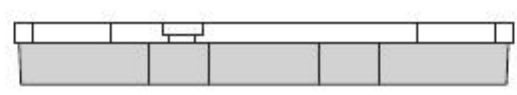
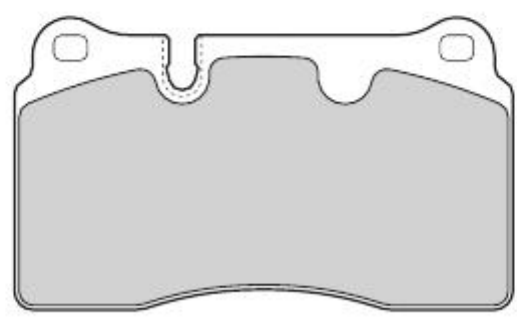



1288	LAND ROVER	BREMBO	X	131,7	77,3	16,5	4		
------	------------	--------	---	-------	------	------	---	--	--



1289	VOLKSWAGEN	BREMBO	X	131,7	77,3	16,5	4		
------	------------	--------	---	-------	------	------	---	--	--



									
<b>1290</b>	MERCEDES - VOLKSWAGEN	BREMBO	X	169,1	73,2	20,1	4		

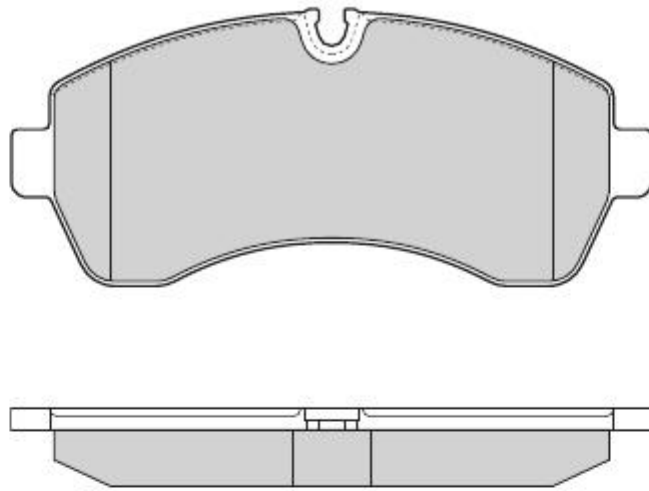



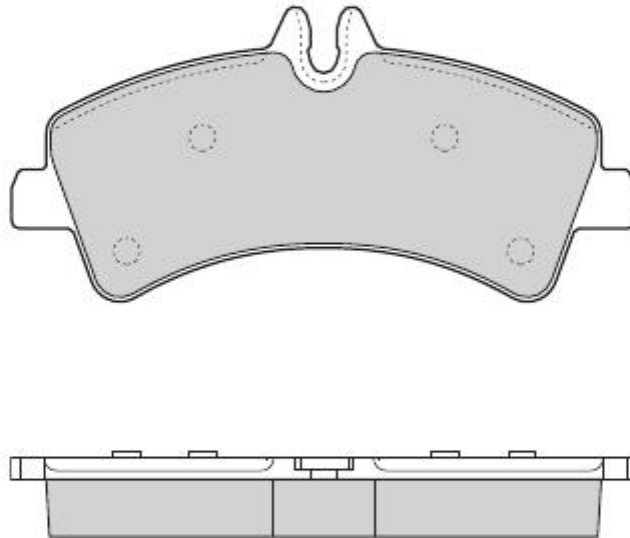



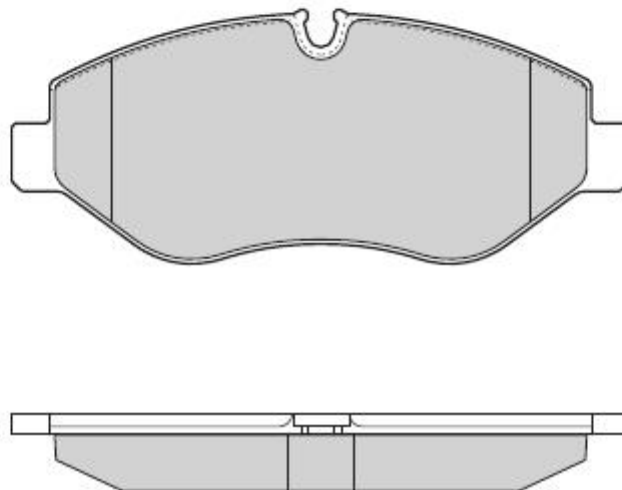

<b>1291</b>	MERCEDES - VOLKSWAGEN	BOSCH	X	164,9	79	20,8	4		
-------------	-----------------------	-------	---	-------	----	------	---	--	--



<b>1292</b>	MERCEDES - VOLKSWAGEN	BREMBO	X	163,1	67,1	20,3	4		
-------------	-----------------------	--------	---	-------	------	------	---	--	--

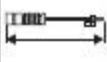

									
1293	MERCEDES - VOLKSWAGEN	BOSCH	X	136,9	63,1	19	4		

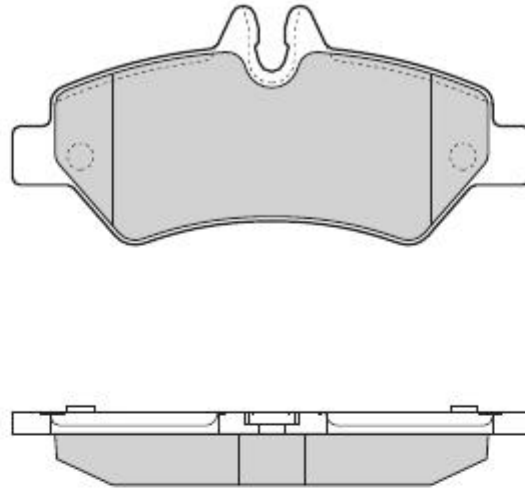



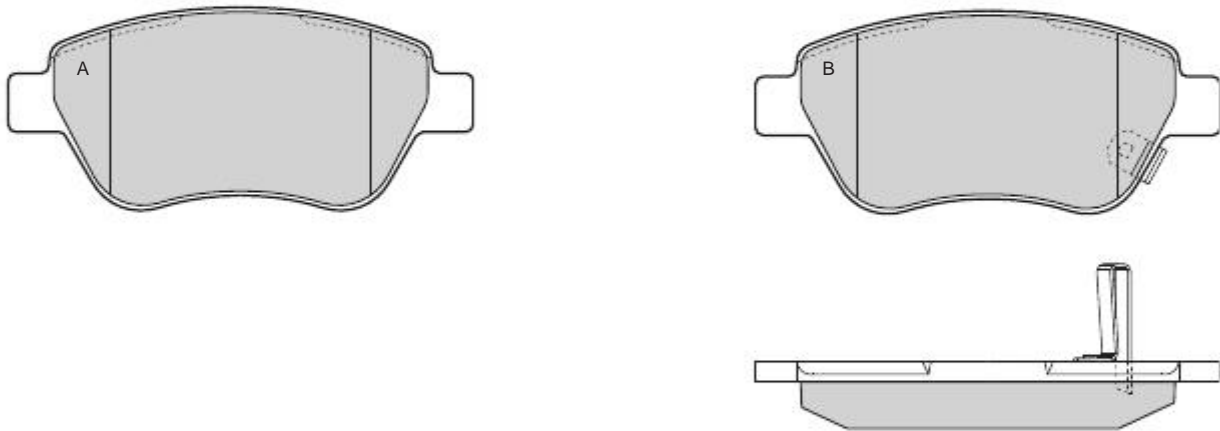



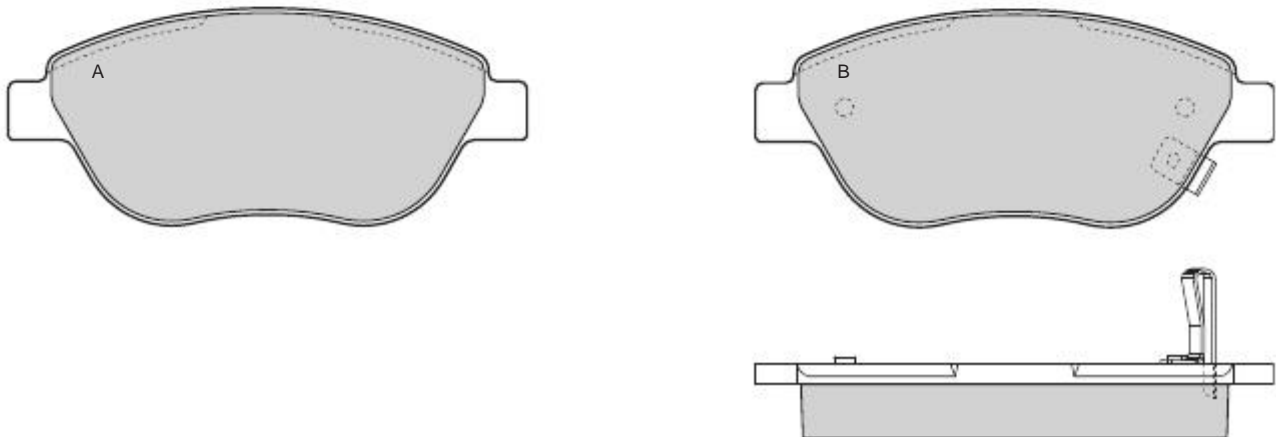

1294	OPEL	BOSCH	X	122,8	53,6	17,8	3A-1B	0	0
------	------	-------	---	-------	------	------	-------	---	---



1295	OPEL	BOSCH	X	136,8	57,9	19,7	3A-1B		
------	------	-------	---	-------	------	------	-------	--	--

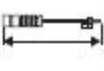

									
<b>1296</b>	<b>MITSUBISHI</b>	<b>TOKICO</b>	<b>X</b>	<b>155,4</b>	<b>51</b>	<b>16</b>	<b>3A-1B</b>		

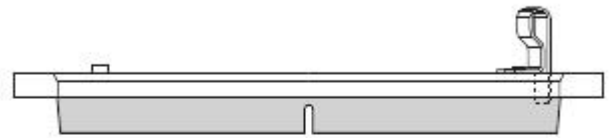
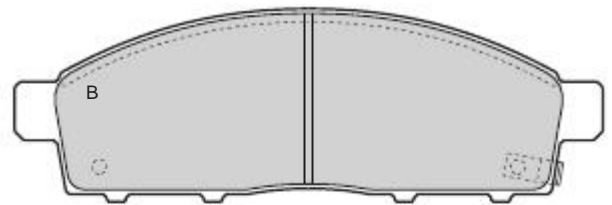
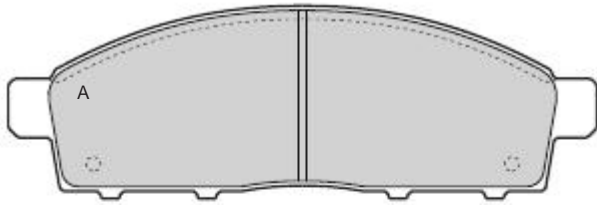



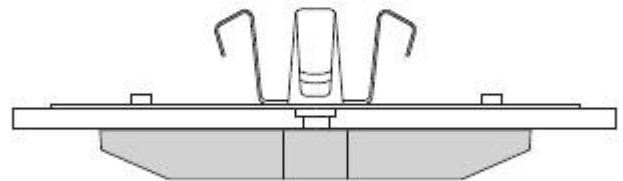
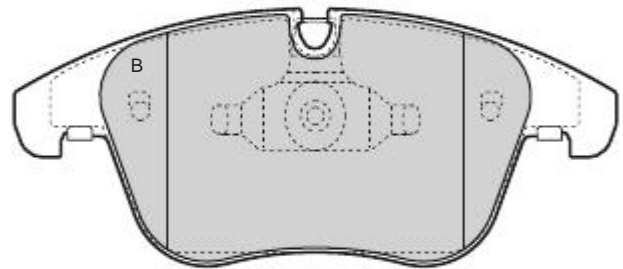
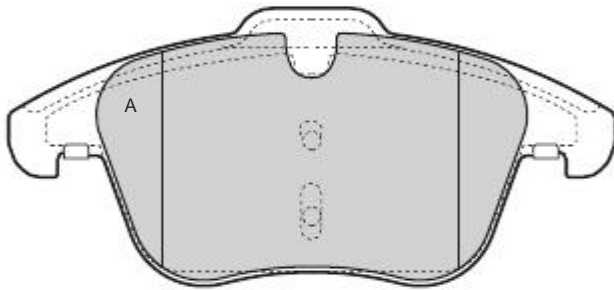



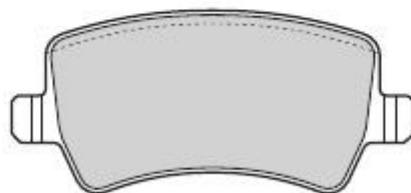

<b>1297</b>	<b>FORD - LAND ROVER VOLVO</b>	<b>ATE</b>	<b>X</b>	<b>155,2</b>	<b>A 72 B 66,7</b>	<b>19</b>	<b>2A-2B</b>		
-------------	------------------------------------	------------	----------	--------------	------------------------	-----------	--------------	--	--



<b>1298</b>	<b>FORD - VOLVO</b>	<b>LUCAS</b>	<b>X</b>	<b>106,2</b>	<b>48,4</b>	<b>16,9</b>	<b>4</b>		
-------------	---------------------	--------------	----------	--------------	-------------	-------------	----------	--	--

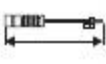

									
1299	FORD - VOLVO	ATE	X	A 156,3 B 155,2	A 74,2 B 75	A 18,5 B 20	2A-2B		

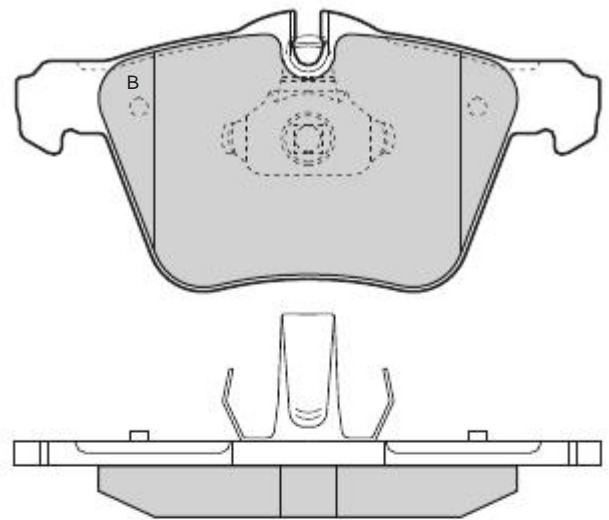
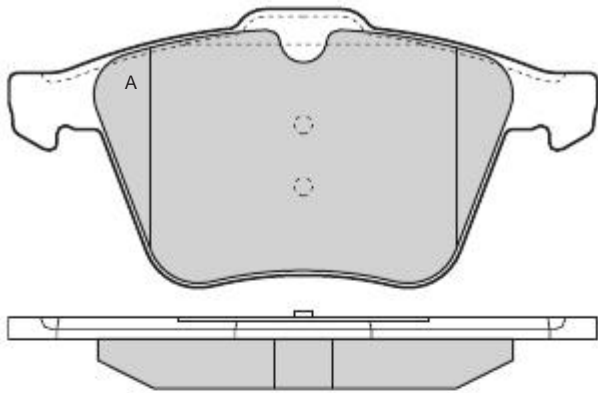



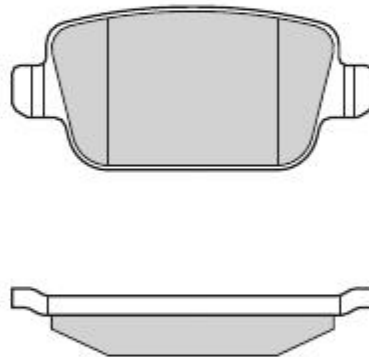



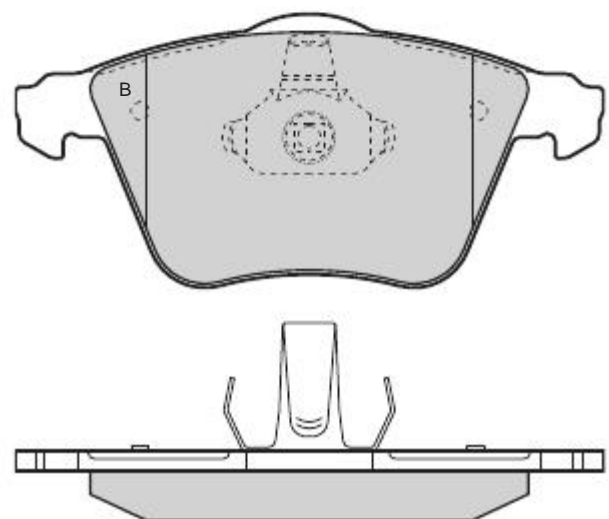
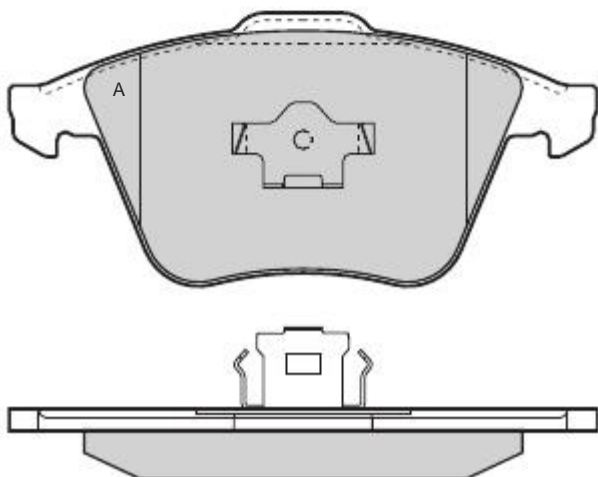

1300	FORD - LAND ROVER VOLVO	LUCAS	X	95,2	43,2	15,7	4		
------	----------------------------	-------	---	------	------	------	---	--	--



1301	OPEL - VOLVO	ATE	X	A 156,2 B 155	72,9	18,5	2A-2B		
------	--------------	-----	---	------------------	------	------	-------	--	--



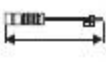

									
1302	VOLKSWAGEN	BREMBO	X	86,9	70,3	17,1	4		

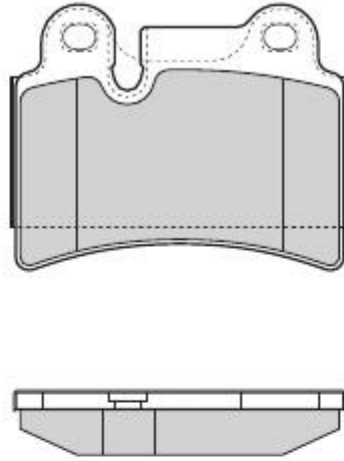



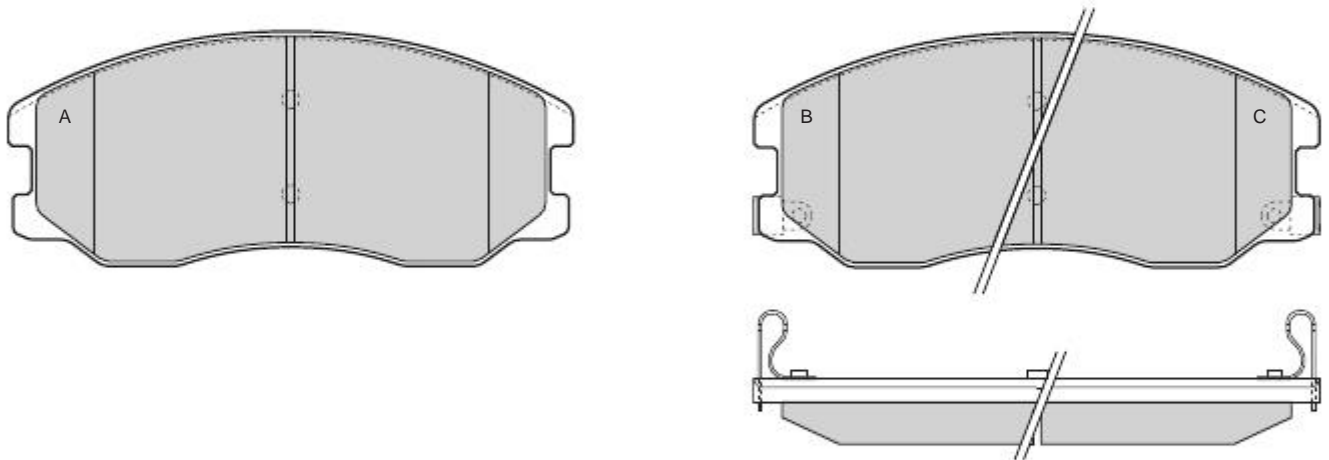



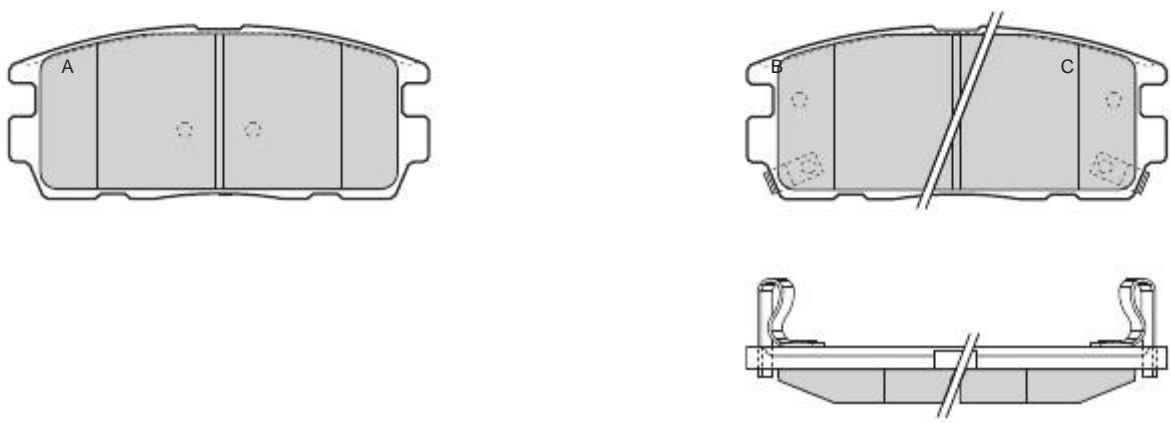

1303	OPEL - CHEVROLET	AKEBONO	X	149,2	62	17	2A 1B-1C		
------	------------------	---------	---	-------	----	----	-------------	--	--



1304	OPEL - CHEVROLET	AKEBONO	X	110,8	45,9	15	2A 1B-1C		
------	------------------	---------	---	-------	------	----	-------------	--	--

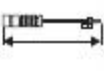

									
<b>1305</b>	MINI (BMW)	LUCAS	X	95,4	A 48,5 B 39,2	16,3	2A-2B		

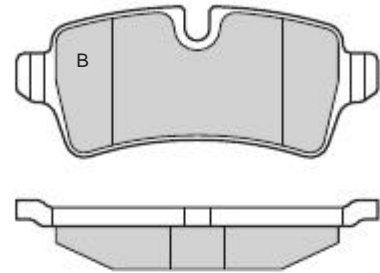
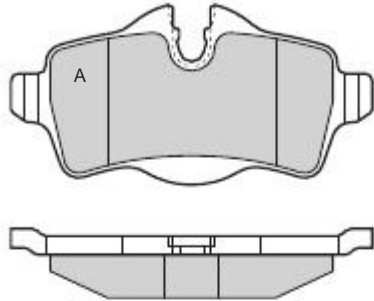



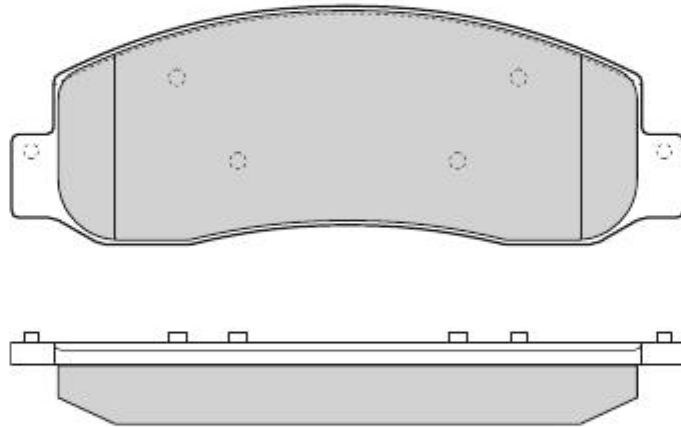



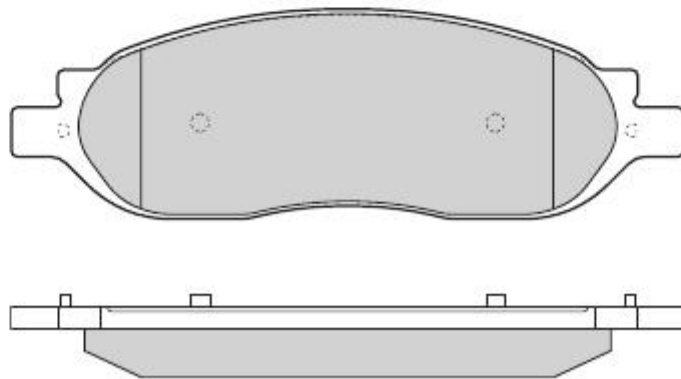

<b>1306</b>	FORD		X	177,4	63	21,5	4		
-------------	------	--	---	-------	----	------	---	--	--



<b>1307</b>	FORD		X	177,6	55,5	18,8	4		
-------------	------	--	---	-------	------	------	---	--	--

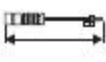

OPTIONAL

									
1308	CHEVROLET		X	177	62,7	17,7	4		

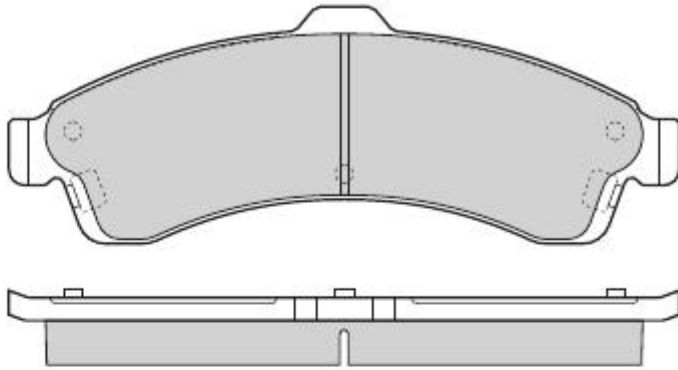

OPTIONAL



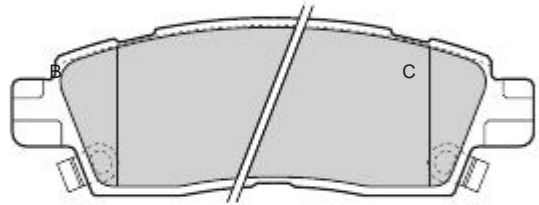



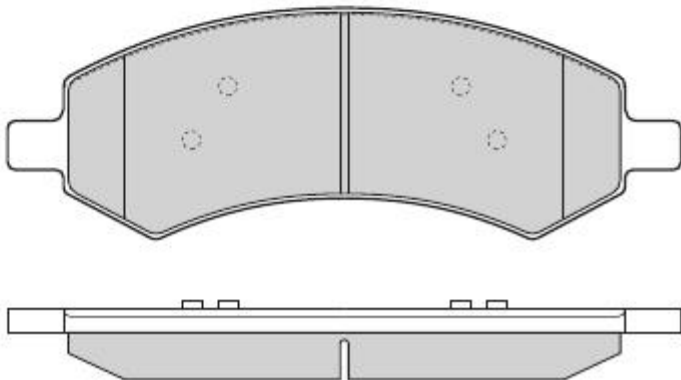



1309	CHEVROLET		X	137,7	47	18,2	2A 1B-1C		
------	-----------	--	---	-------	----	------	-------------	--	--



1310	DODGE		X	177,8	61,2	18,5	4		
------	-------	--	---	-------	------	------	---	--	--



OPTIONAL

									
1311	DODGE		X	166,2	49,4	16,8	4		

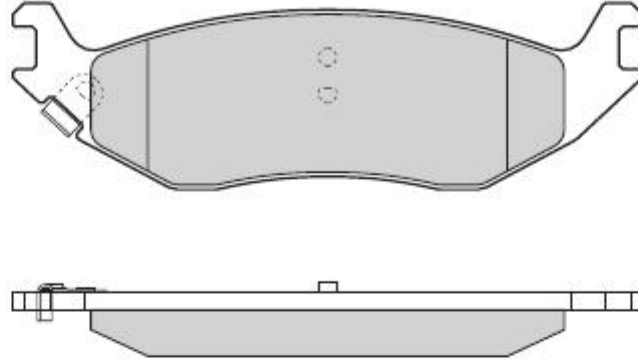



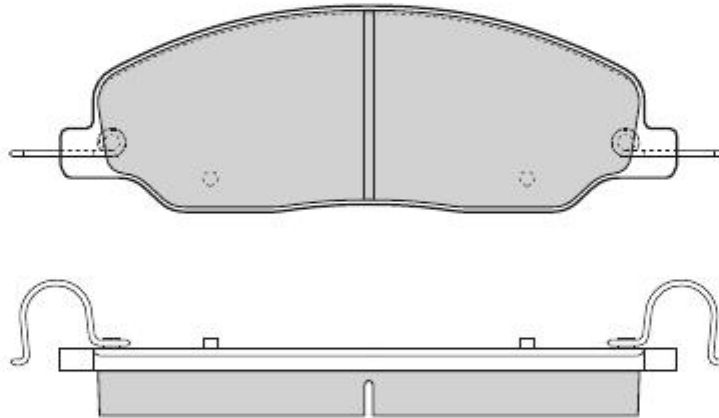



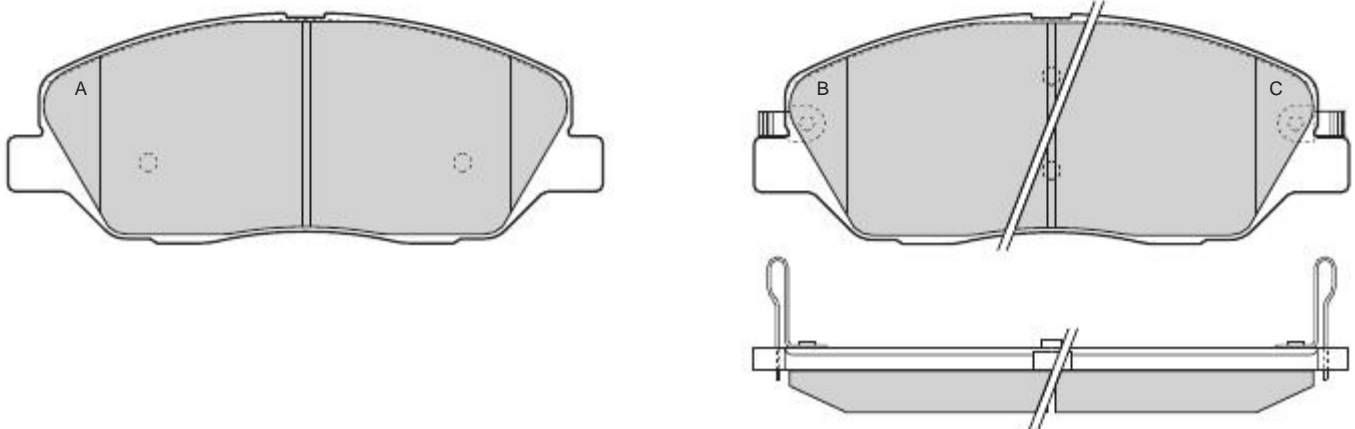

1312	FORD (USA)		X	162,6	54,5	17,8	4		
------	------------	--	---	-------	------	------	---	--	--



1313	HYUNDAI - KIA	MANDO	X	156,8	60,9	17	2A 1B-1C		
------	---------------	-------	---	-------	------	----	-------------	--	--

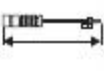

									
1314	HYUNDAI	MANDO	X	118,6	47	15,6	2A 1B-1C		

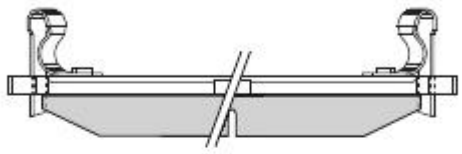
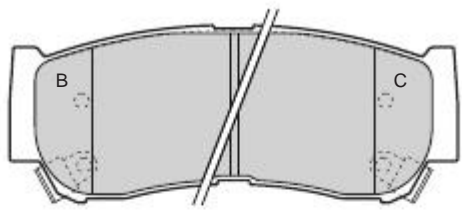
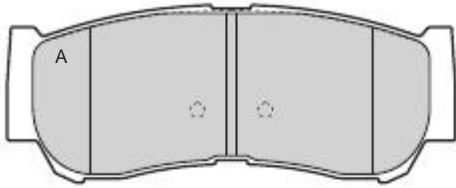



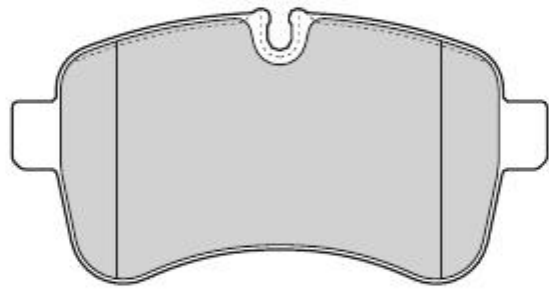



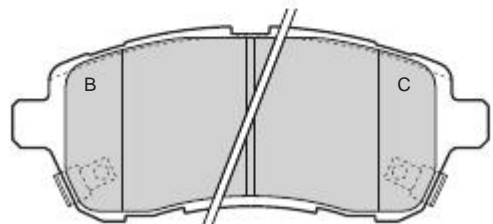
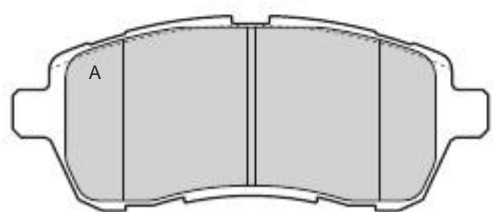

1315	IVECO	BREMBO	X	141,2	72,7	21	4		
------	-------	--------	---	-------	------	----	---	--	--



1316	MAZDA	LUCAS	X	125,6	51,6	16,5	2A 1B-1C		
------	-------	-------	---	-------	------	------	-------------	--	--

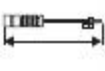

									
1317	MERCEDES	LUCAS	X	188	A 73,4 B 80,4	19,4	2A-2B		

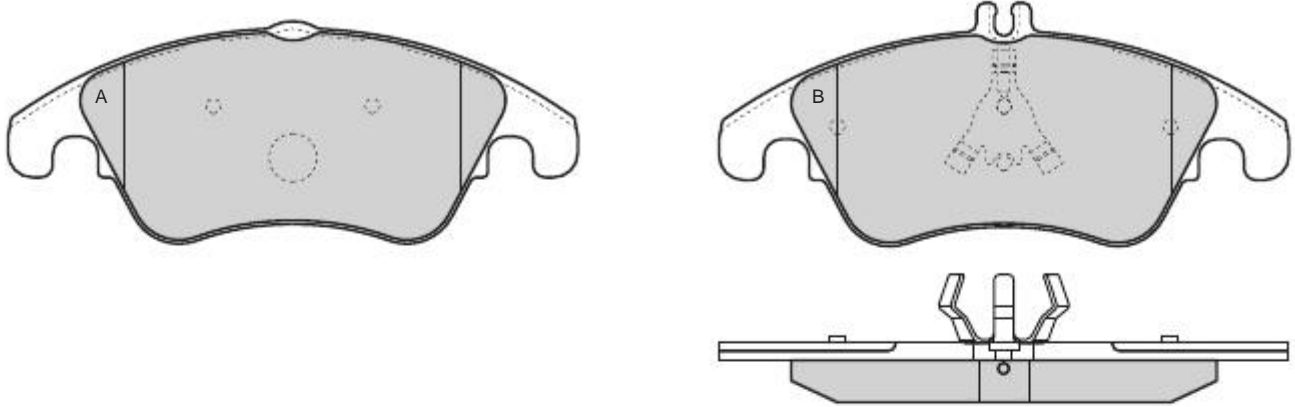



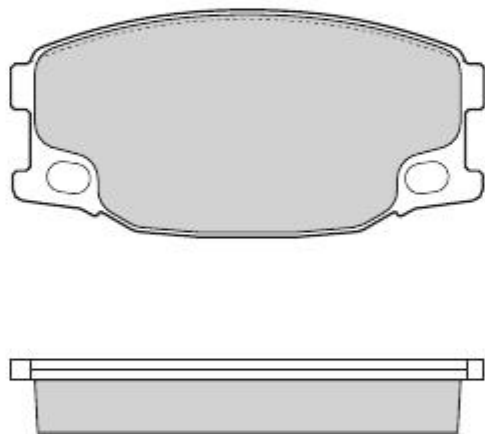



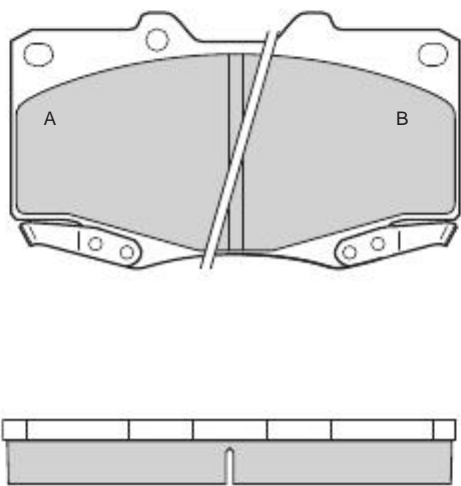



1318	MITSUBISHI	SUMITOMO	X	125	60	19,4	4		
------	------------	----------	---	-----	----	------	---	--	--



1319	TOYOTA	SUMITOMO	X	119,4	68,1	17	2A-2B		
------	--------	----------	---	-------	------	----	-------	--	--



									
<b>1320</b>	TOYOTA	ATE	X	123,1	43,7	A 15 B-C 14,8	2A 1B-1C		

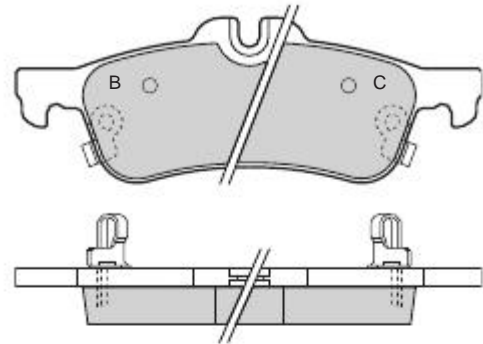
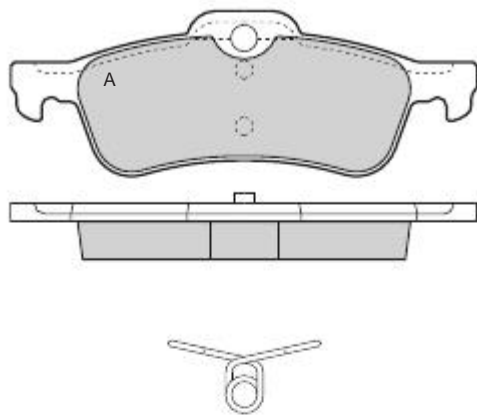



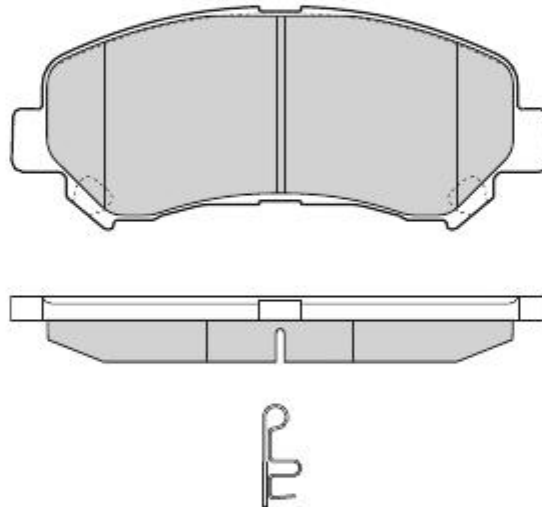



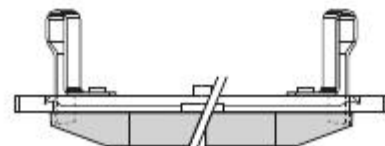
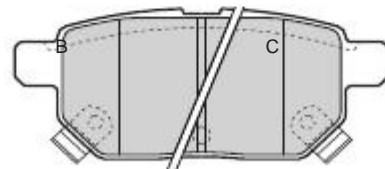
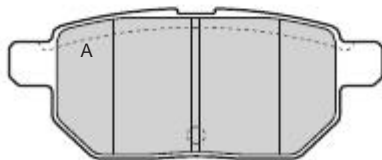

<b>1321</b>	NISSAN	AKEBONO	X	141,8	58,9	17	4		
-------------	--------	---------	---	-------	------	----	---	--	--



<b>1322</b>	TOYOTA	AKEBONO	X	98,6	42,6	14,4	2A 1B-1C		
-------------	--------	---------	---	------	------	------	-------------	--	--

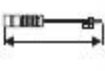

									
<b>1323</b>	CITROEN - FIAT - PEUGEOT	BREMBO	X	169,1	69,1	19,1	3A-1B	1	190

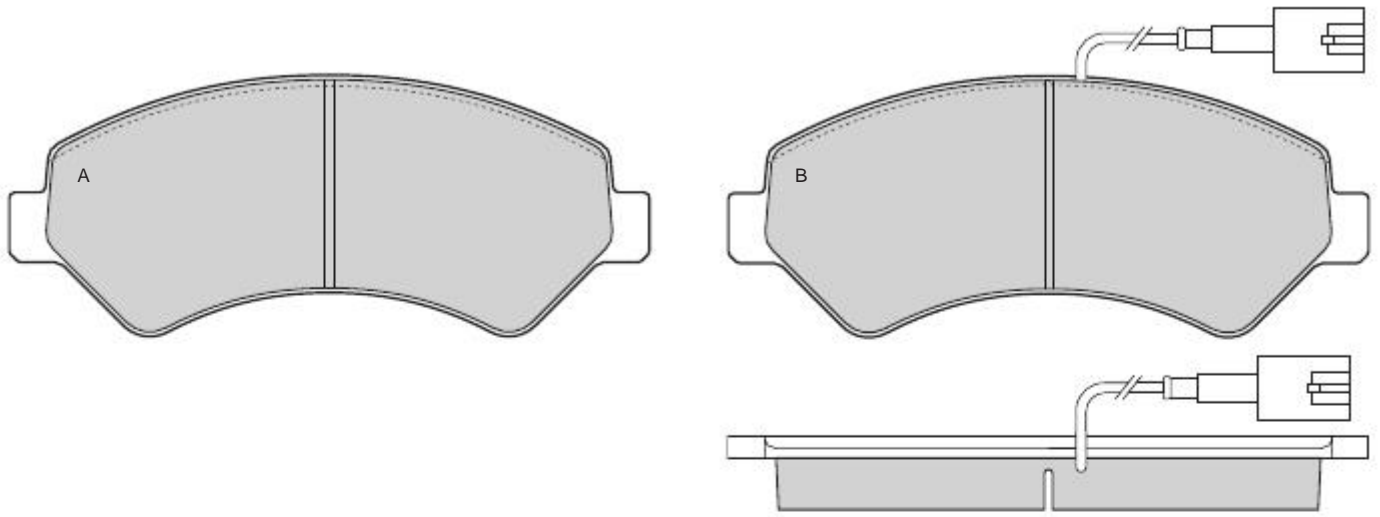



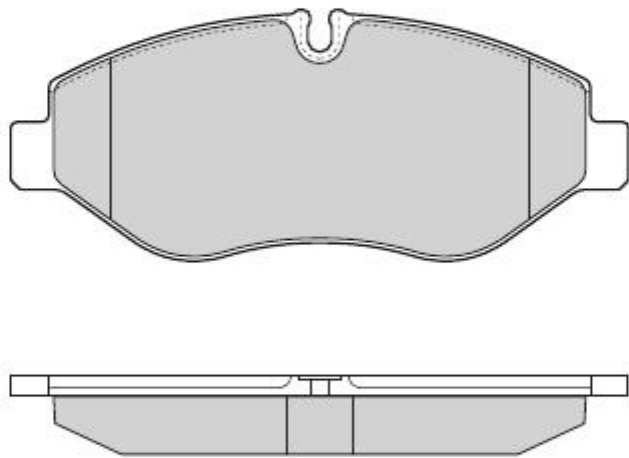



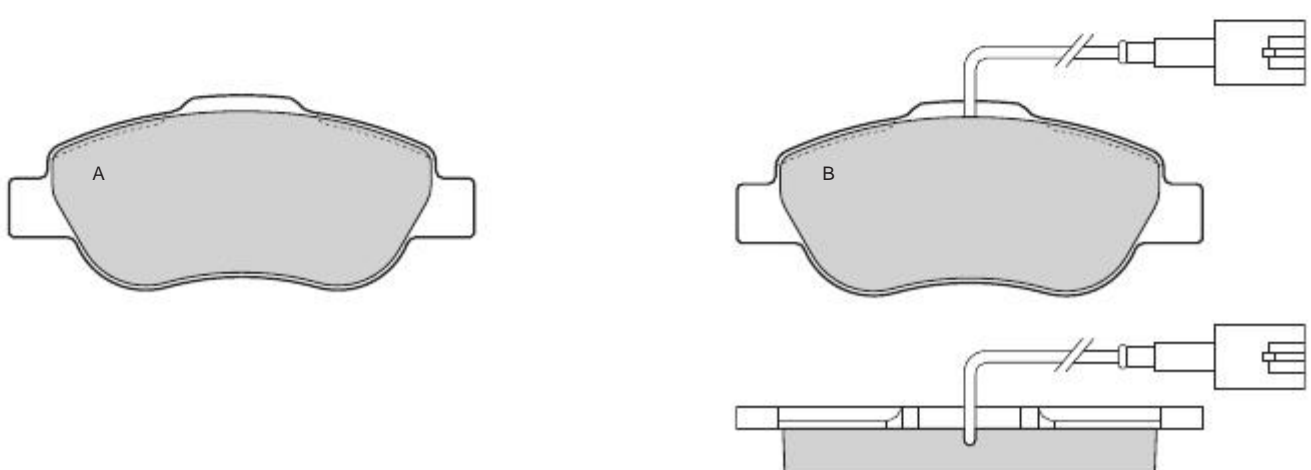



<b>1324</b>	IVECO	BREMBO	X	163,1	66,7	20,9	4		
-------------	-------	--------	---	-------	------	------	---	--	--



<b>1325</b>	FIAT	BOSCH	X	122,8	51,4	17,8	3A-1B	1	190
-------------	------	-------	---	-------	------	------	-------	---	-----





										
1326	FIAT	BOSCH	X		114,9	55,6	17	4	1	180

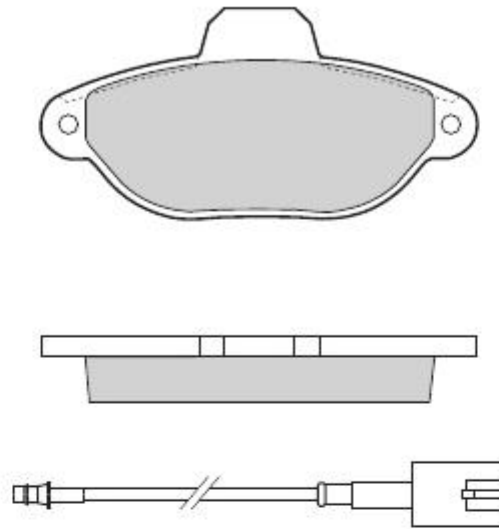



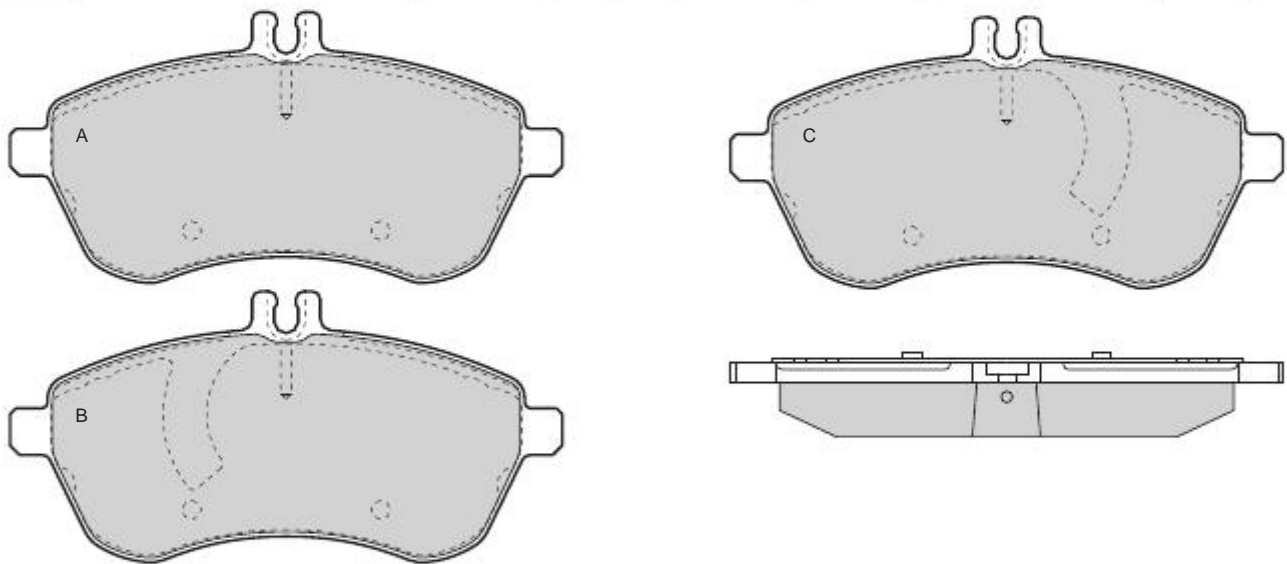



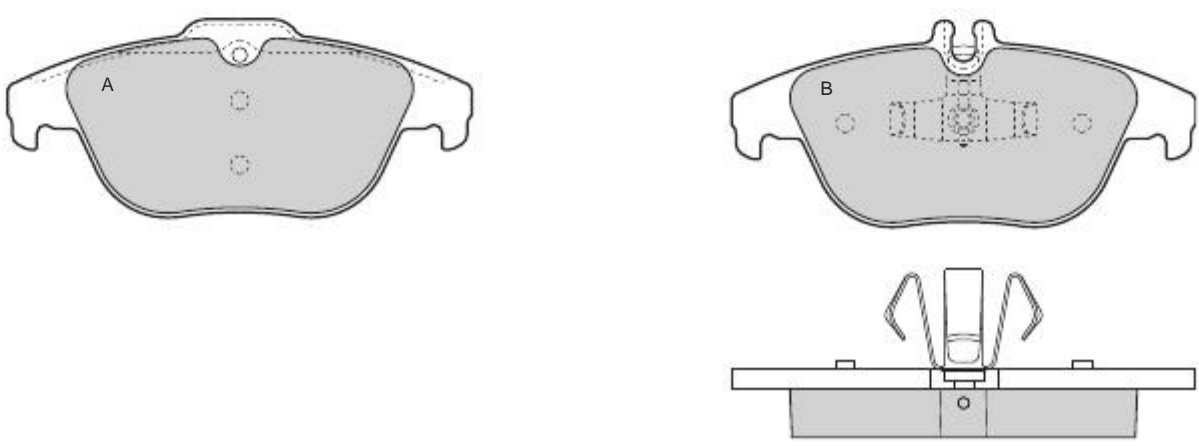

1327	MERCEDES	LUCAS	X		146	71,7	20,6	2A 1B-1C		
------	----------	-------	---	--	-----	------	------	-------------	--	--



1328	MERCEDES	ATE	X		122,5	A 52,4 B 54,6	17,8	2A-2B		
------	----------	-----	---	--	-------	------------------	------	-------	--	--

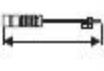

									
<b>1329</b>	CITROEN	ATE	X	155,1	A 64,5 B 57,8	A 18,6 B 19,6	2A-2B		

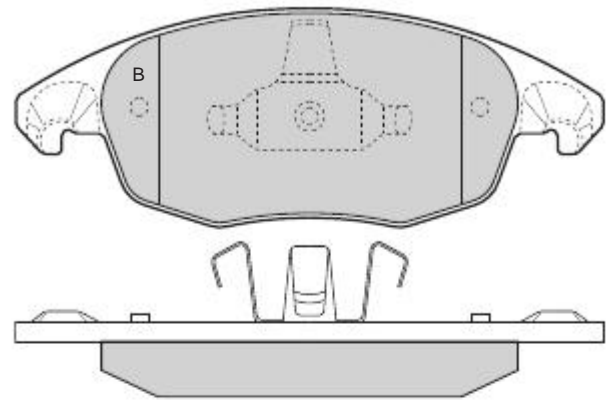
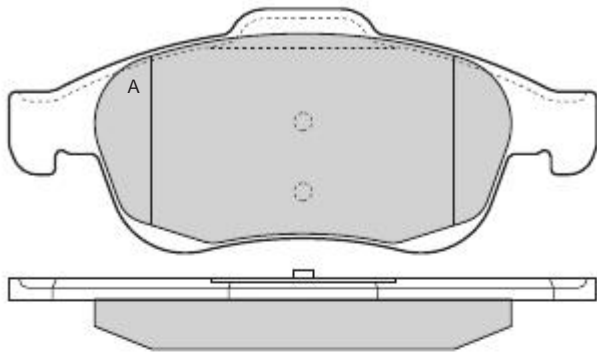



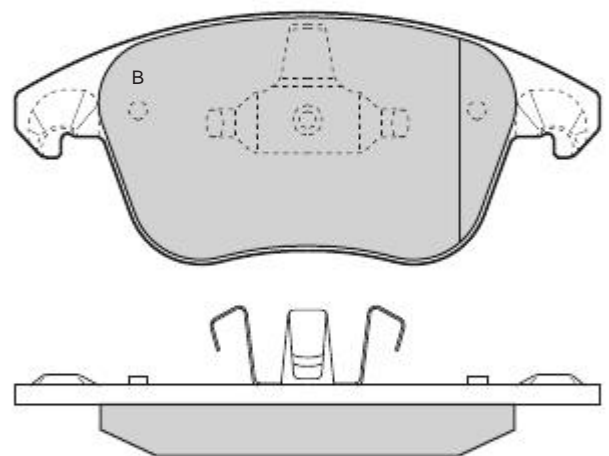
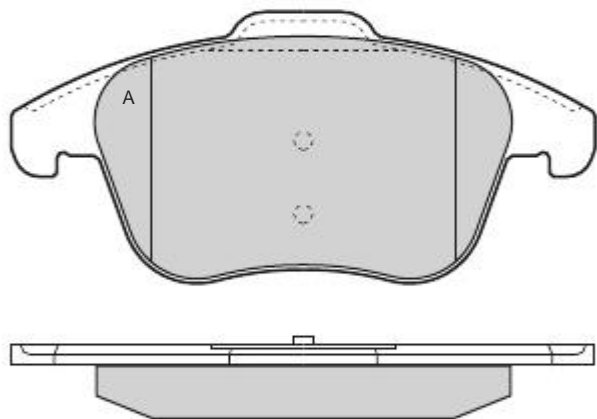



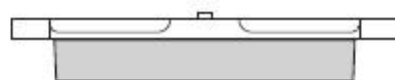
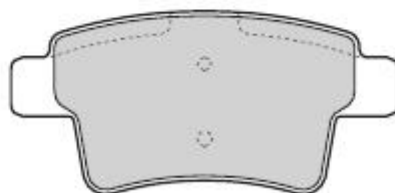



<b>1330</b>	CITROEN	ATE	X	155,1	A 72,2 B 66,9	A 19,5 B 18,7	2A-2B		
-------------	---------	-----	---	-------	------------------	------------------	-------	--	--



<b>1331</b>	CITROEN	BOSCH	X	102,3	48,4	16,3	4		
-------------	---------	-------	---	-------	------	------	---	--	--



									
<b>1332</b>	MAZDA	SUMITOMO	X	138,9	58	17,5	4		

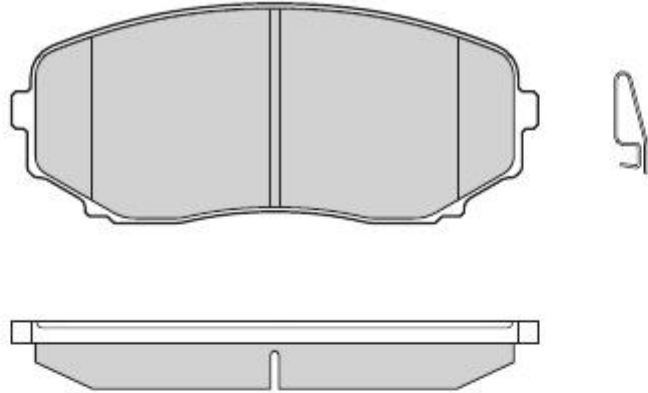



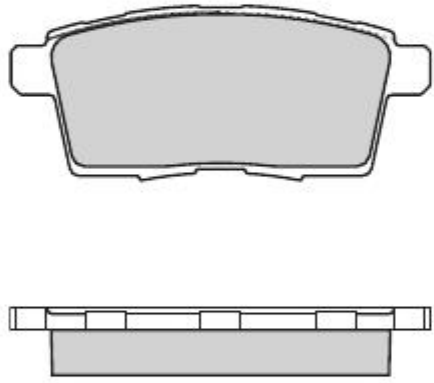



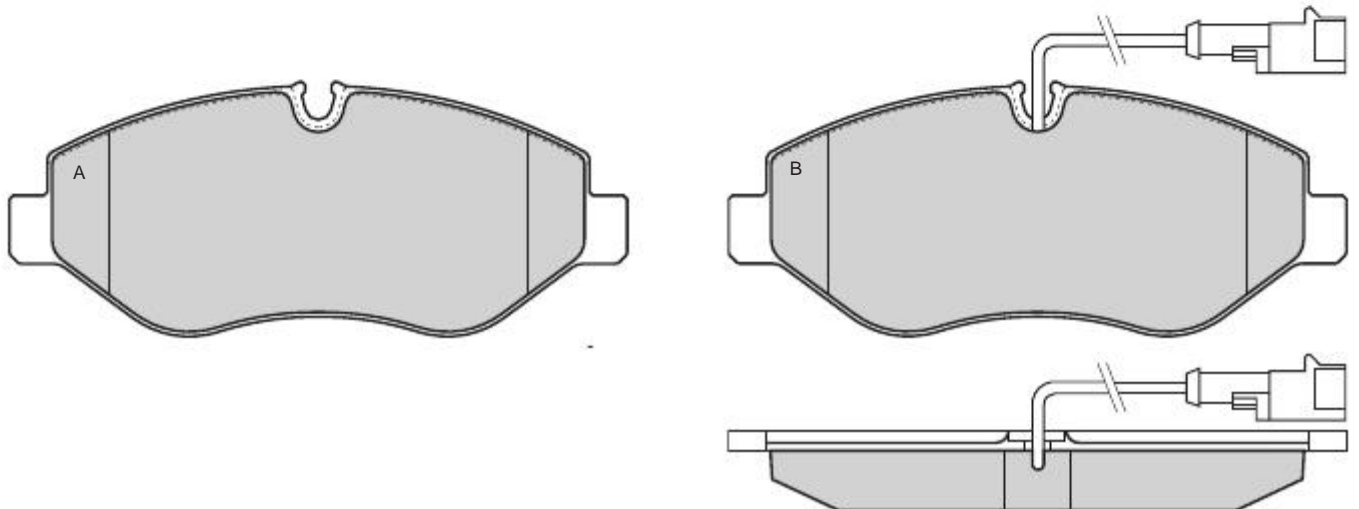

<b>1333</b>	MAZDA	SUMITOMO	X	110,7	46,1	17,9	4		
-------------	-------	----------	---	-------	------	------	---	--	--



<b>1334</b>	NISSAN - RENAULT	BREMBO	X	163,1	67,1	21	2A-2B	2	220
-------------	------------------	--------	---	-------	------	----	-------	---	-----

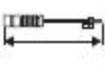

									
<b>1335</b>	NISSAN	SUMITOMO	X	144,3	49,1	15	2A 1B-1C		

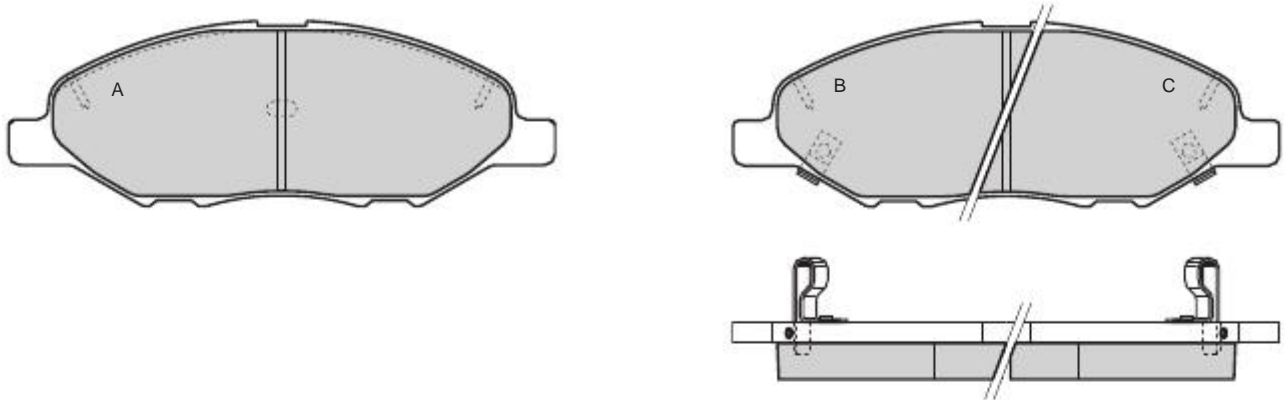



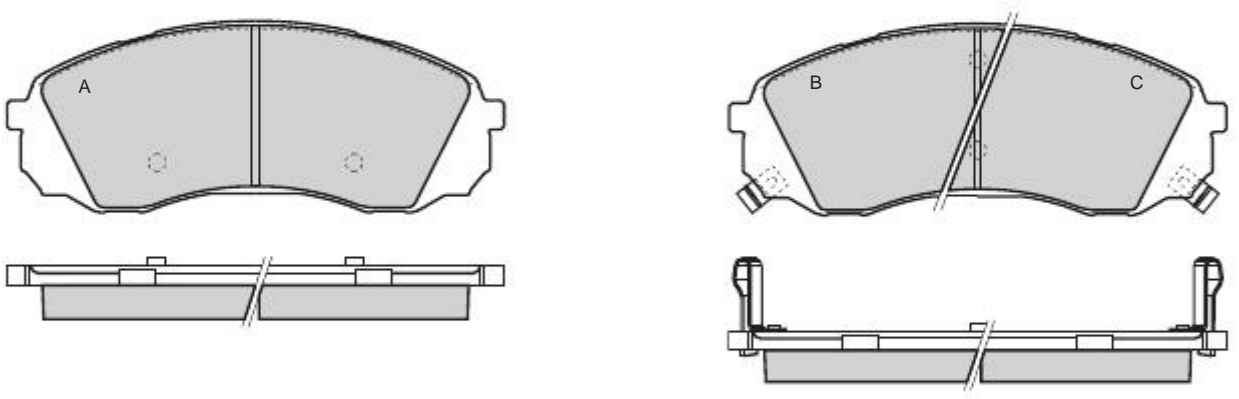



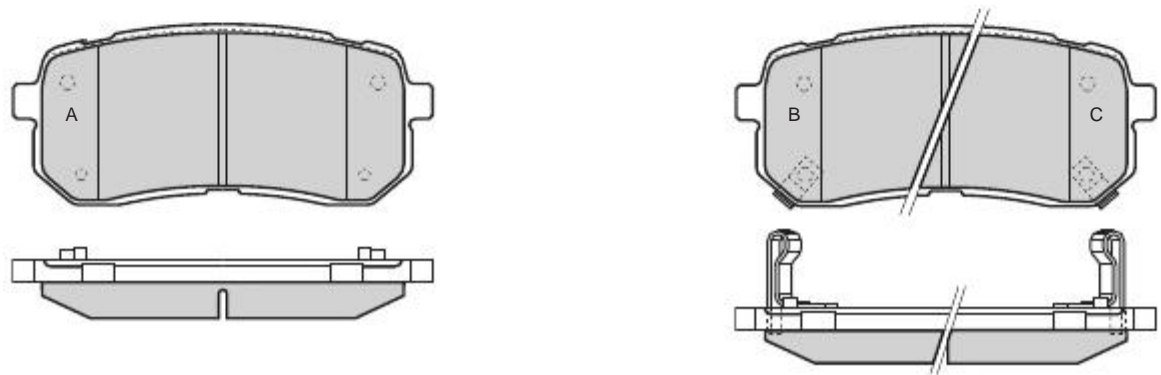



<b>1336</b>	KIA	MANDO	X	164,4	63,3	A 17,6 B 16,8	2A 1B-1C		
-------------	-----	-------	---	-------	------	------------------	-------------	--	--



<b>1337</b>	KIA	MANDO	X	110,7	47,7	14,9	2A 1B-1C		
-------------	-----	-------	---	-------	------	------	-------------	--	--



									
<b>1338</b>	LANCIA	LUCAS	X	116,5	55,2	16,5	3A-1B		220

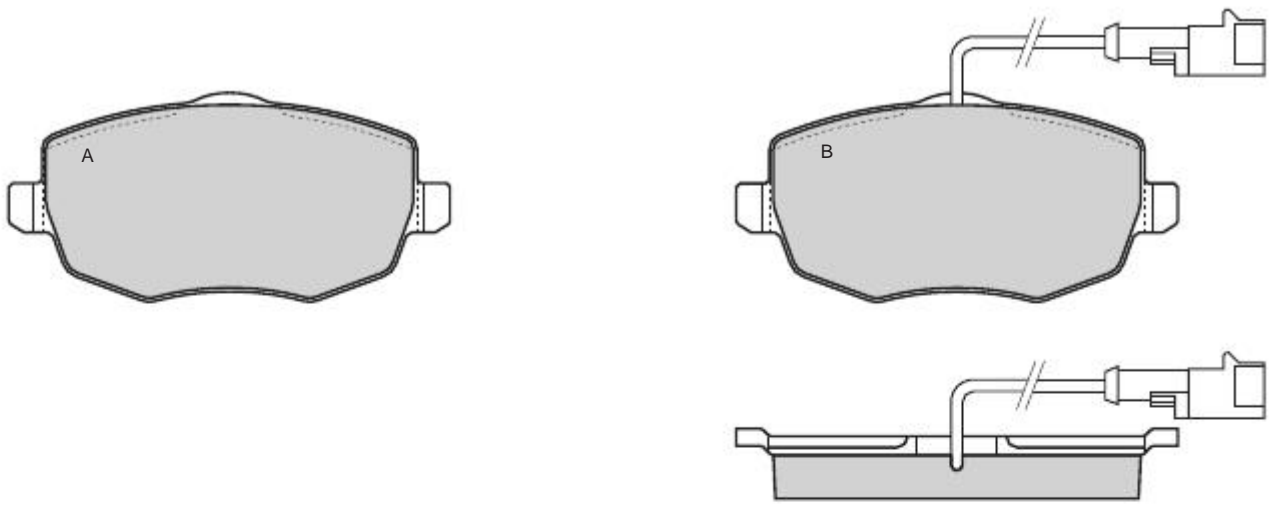



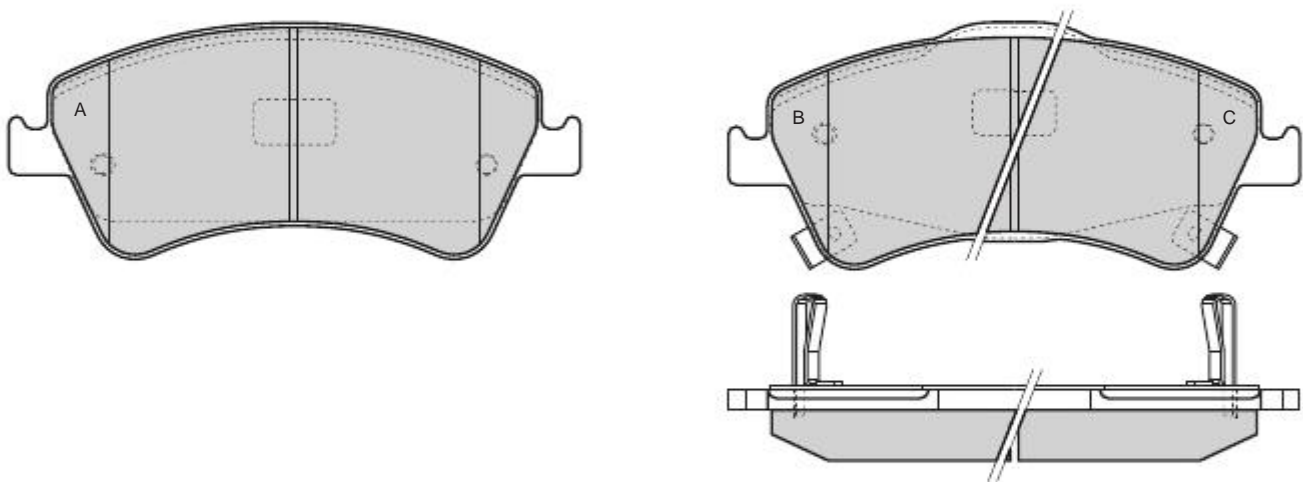



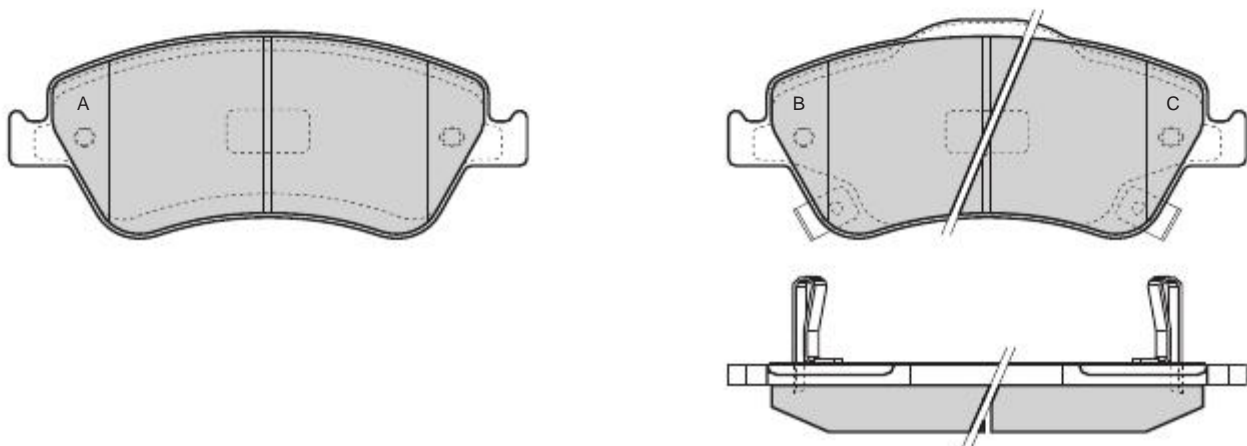

<b>1339</b>	TOYOTA	BOSCH	X	150,8	A 62,5 B 65,3	19,5	2A 1B-1C		
-------------	--------	-------	---	-------	------------------	------	-------------	--	--



<b>1340</b>	TOYOTA	BOSCH	X	136,7	A 57,9 B 61,4	19,2	2A 1B-1C		
-------------	--------	-------	---	-------	------------------	------	-------------	--	--

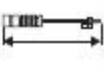

									
1341	TOYOTA	BOSCH	X	102,2	45,9	16,5	2A 1B-1C		

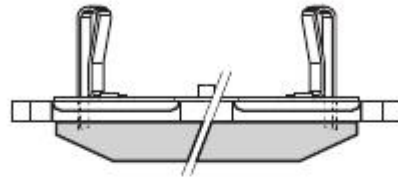
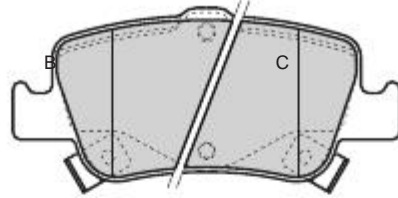
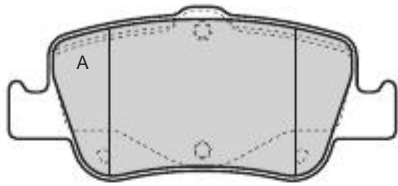



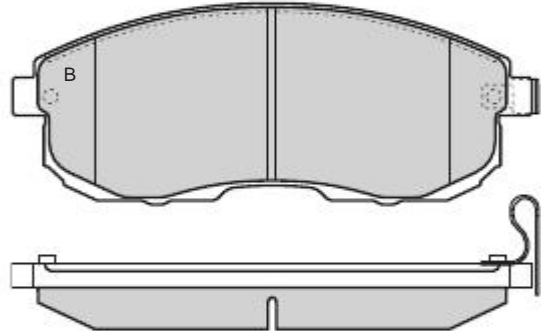
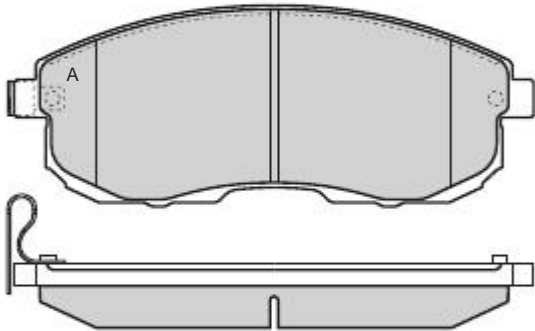



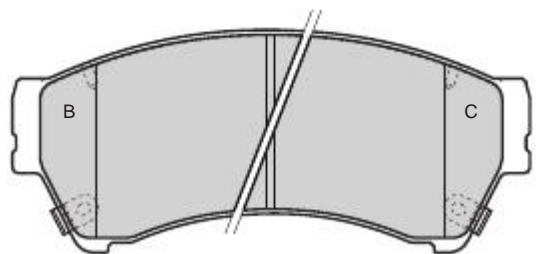
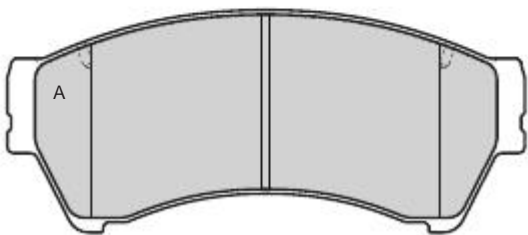

1342	FIAT - NISSAN - SUZUKI	LUCAS	X	137,1	53,1	17	2A-2B		
------	------------------------	-------	---	-------	------	----	-------	--	--



1343	MAZDA	AKEBONO	X	136,6	58,8	17,5	2A 1B-1C		
------	-------	---------	---	-------	------	------	-------------	--	--

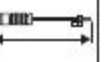

									
1344	CADILLAC	WAGNER	X	182,5	56,8	15,2	4		

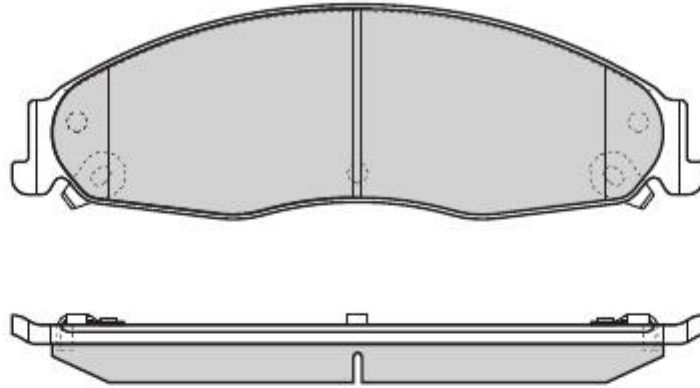



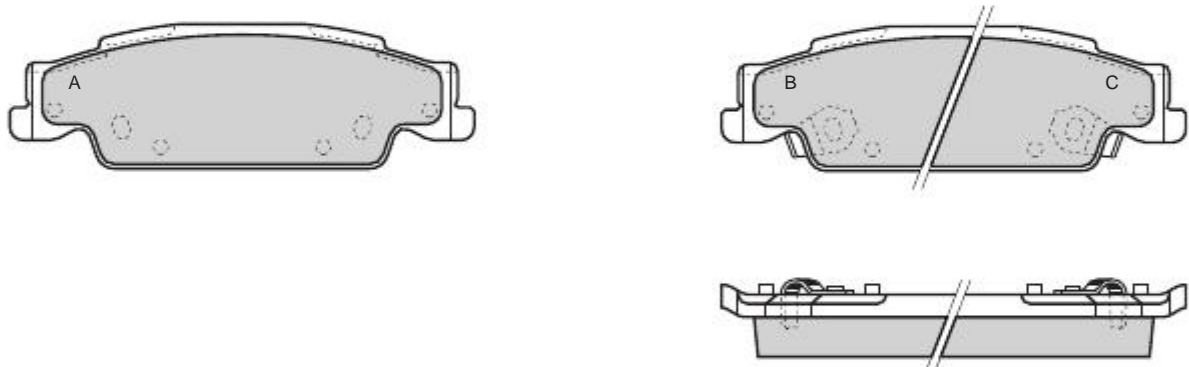



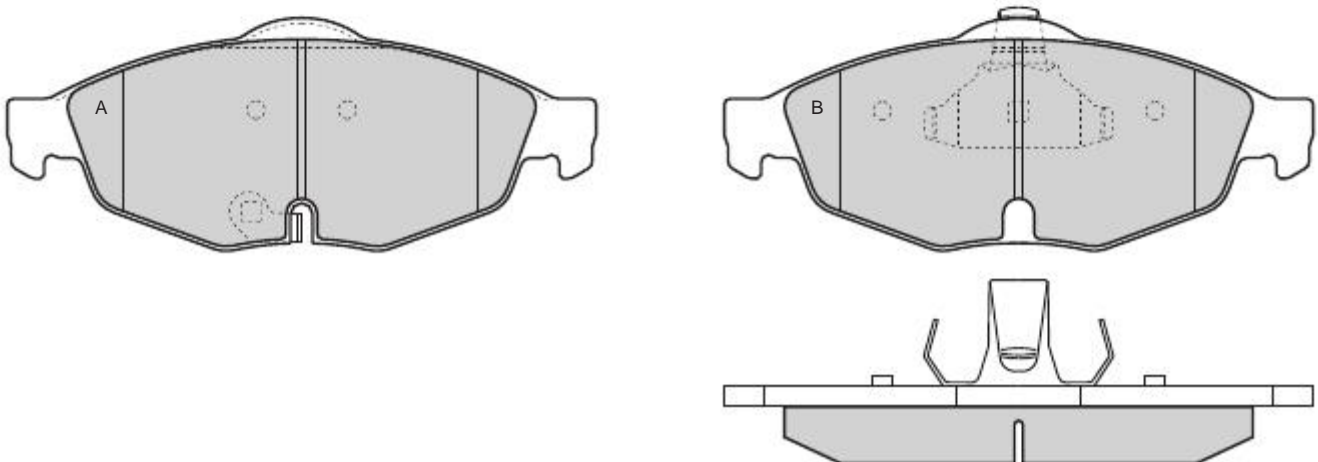



1345	CADILLAC	WAGNER	X	122,6	38,2	16,5	2A 1B-1C		
------	----------	--------	---	-------	------	------	-------------	--	--



1346	CHRYSLER	ATE	X	155,5	62	20,5	2A-2B		
------	----------	-----	---	-------	----	------	-------	--	--



									
<b>1347</b>	AUDI	LUCAS	X	187,8	A 72,9 B 73,5	18,4	2A-2B	1	295

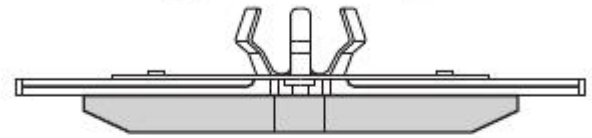
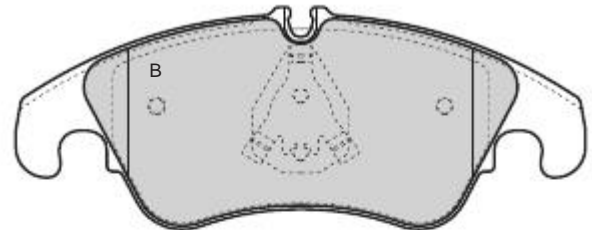
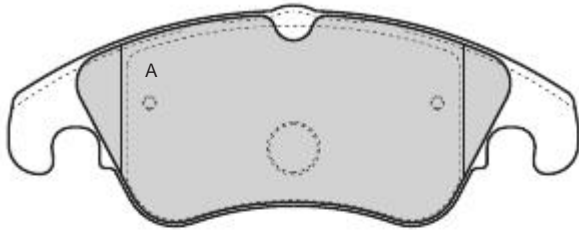



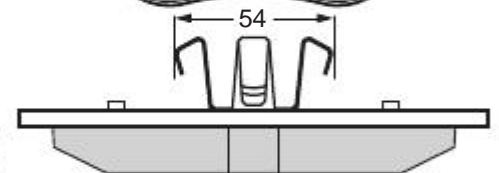
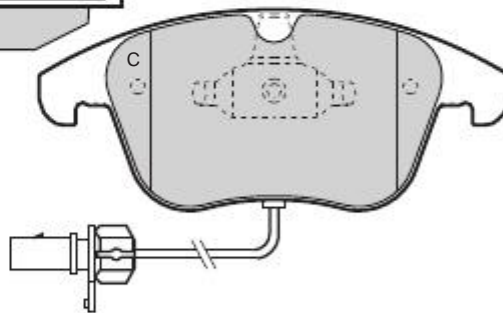
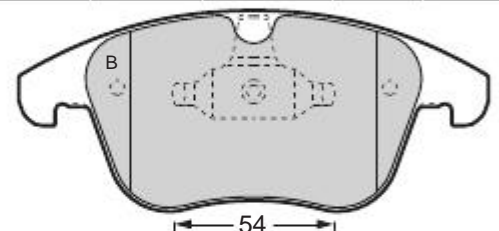
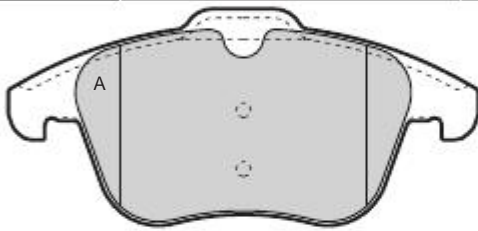



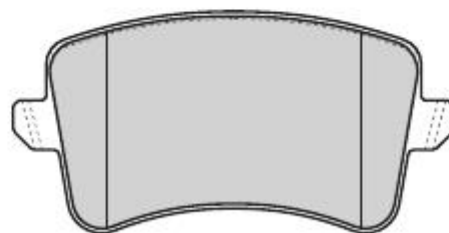

<b>1348</b>	AUDI	ATE	X	155,2	A 71,6 B-C 66,4	A 19,7 B-C 20,7	2A 1B-1C	1	200
-------------	------	-----	---	-------	--------------------	--------------------	-------------	---	-----



<b>1349</b>	AUDI	LUCAS	X	116,4	58,5	17,5	4		
-------------	------	-------	---	-------	------	------	---	--	--



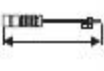

									
<b>1350</b>	NISSAN - RENAULT	SUMITOMO	X	157	58,4	17	2A-2B		

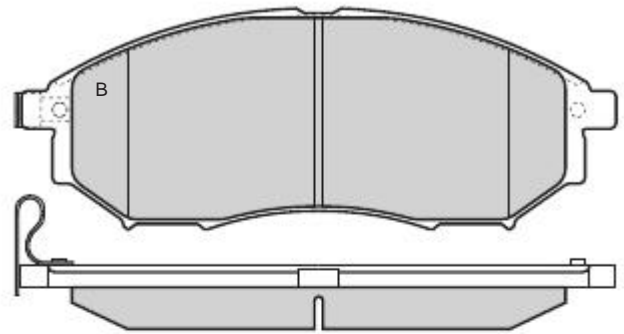
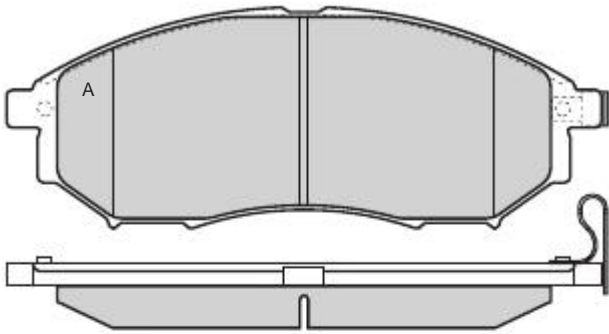



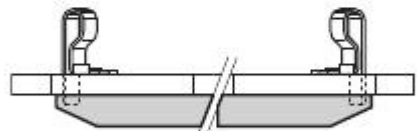
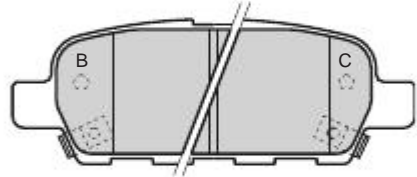
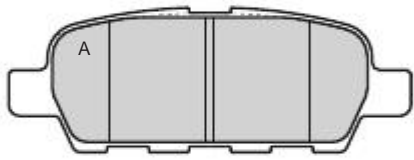



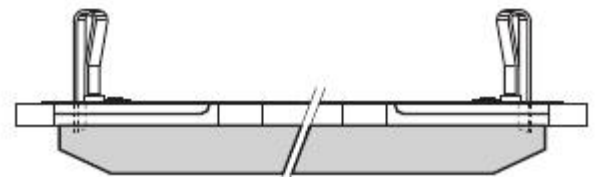
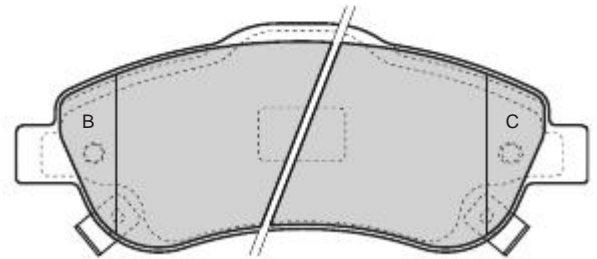
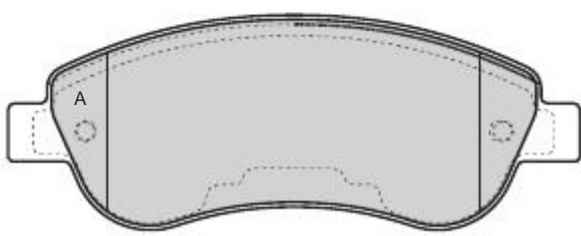



<b>1351</b>	NISSAN - RENAULT	AKEBONO	X	105,4	39	13,7	2A 1B-1C		
-------------	------------------	---------	---	-------	----	------	-------------	--	--



<b>1352</b>	HONDA	BOSCH	X	151	A 56,8 B-C 60,4	19	2A 1B-1C		
-------------	-------	-------	---	-----	--------------------	----	-------------	--	--



									
<b>1353</b>	HONDA	BOSCH	X	108,7	42,2	16,5	2A 1B-1C		

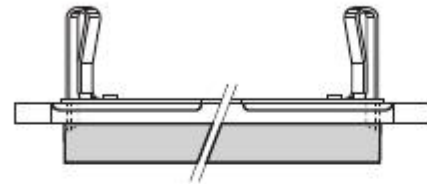
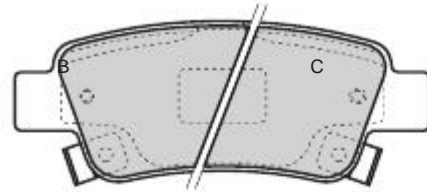
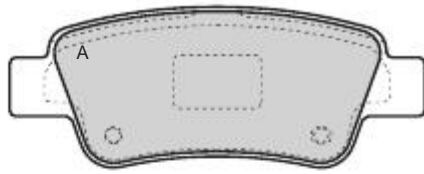



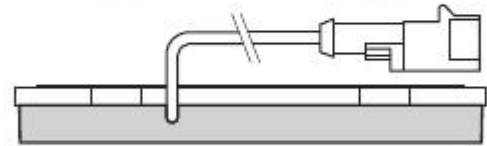
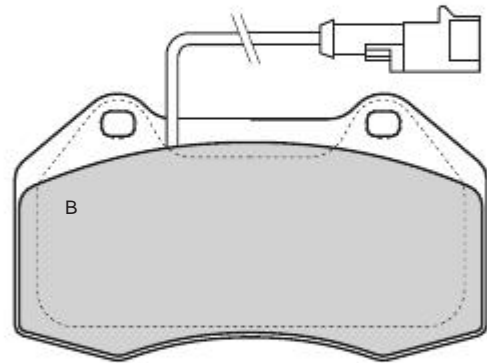
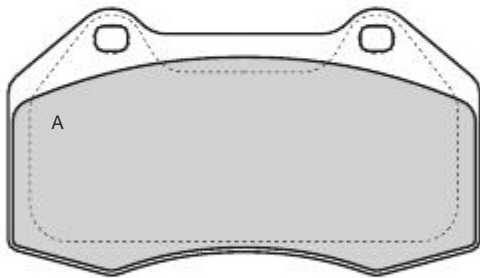



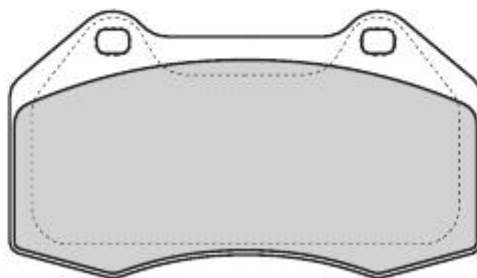



<b>1354</b>	ALFA ROMEO - FIAT	BREMBO	X	124,6	70,4	15,2	3A-1B	2	190
-------------	-------------------	--------	---	-------	------	------	-------	---	-----



<b>1355</b>	RENAULT	BREMBO	X	124,6	70,4	15,2	4		
-------------	---------	--------	---	-------	------	------	---	--	--



									
1356	RENAULT	ATE	X	155,4	A 68,5 B 71	18,3	2A-2B		

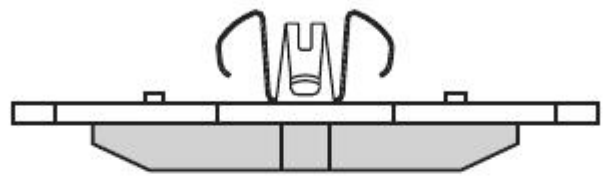
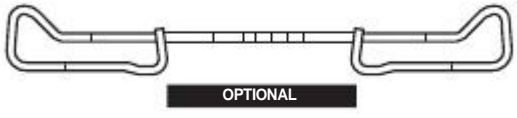
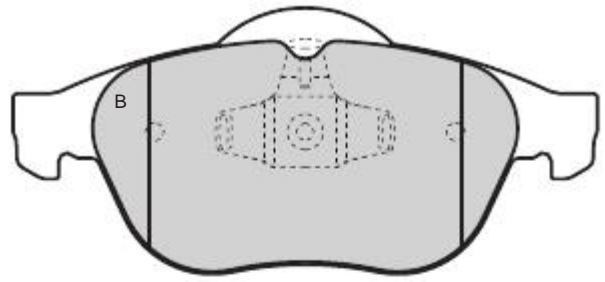
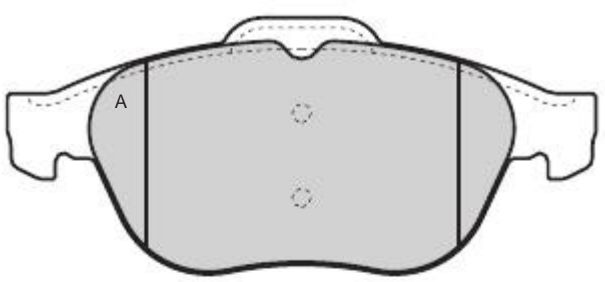



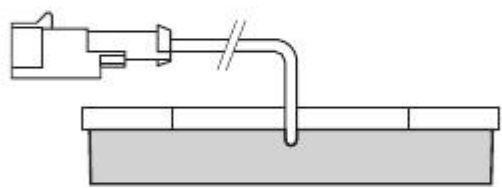
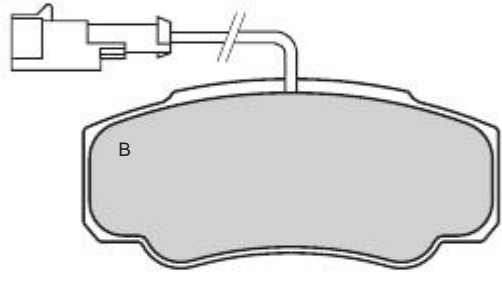
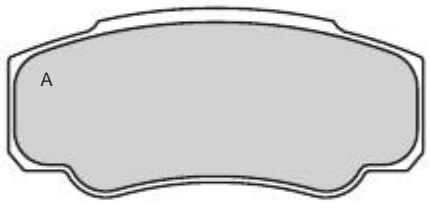



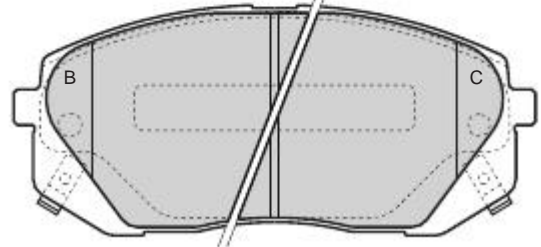
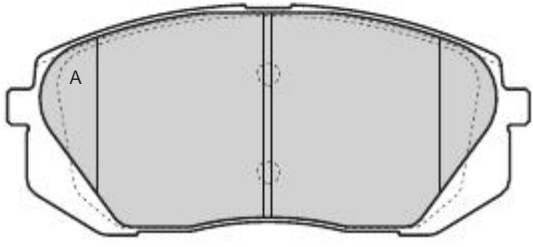



1357	NISSAN - RENAULT	BREMBO	X	109,6	50	19,9	2A-2B	2	255
------	------------------	--------	---	-------	----	------	-------	---	-----



1358	KIA	MANDO	X	137,8	61	16,6	2A 1B-1C		
------	-----	-------	---	-------	----	------	-------------	--	--



									
<b>1359</b>	KIA	MANDO	X	100,6	44	16	2A 1B-1C		

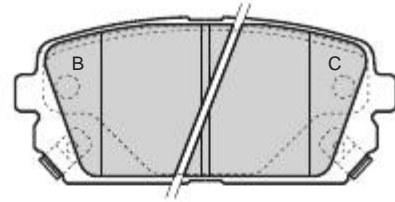
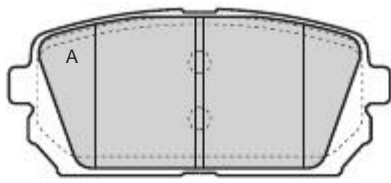



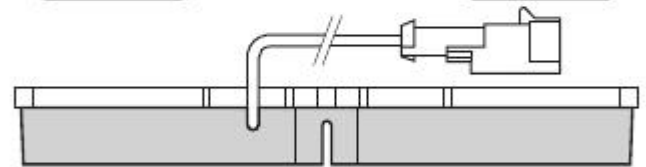
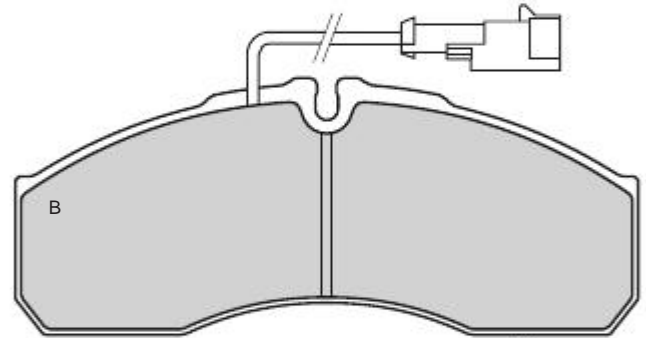
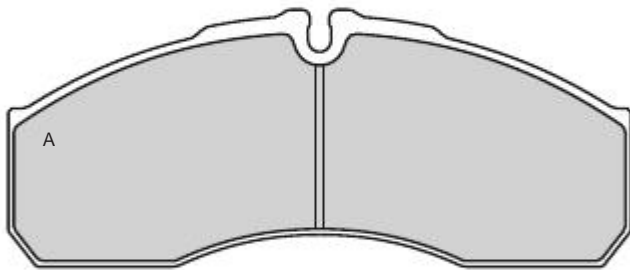



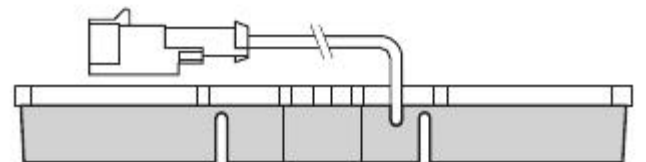
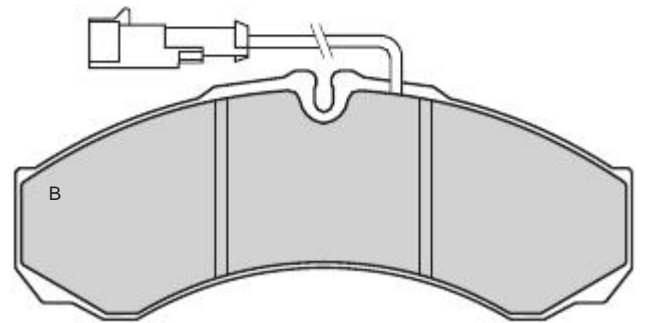
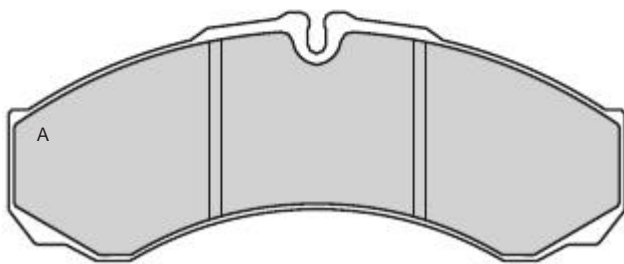

<b>1360</b>	NISSAN - RENAULT	BREMBO	X	164,6	68	20	2A-2B	2	255
-------------	------------------	--------	---	-------	----	----	-------	---	-----



<b>1361</b>	NISSAN - RENAULT	BREMBO	X	164,8	66,5	20	2A-2B	2	255
-------------	------------------	--------	---	-------	------	----	-------	---	-----

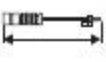

									
<b>1362</b>	MERCEDES	BREMBO	X	141,5	75,85	18	4		

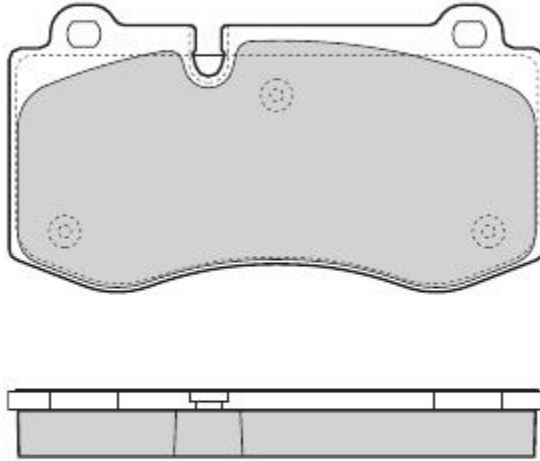



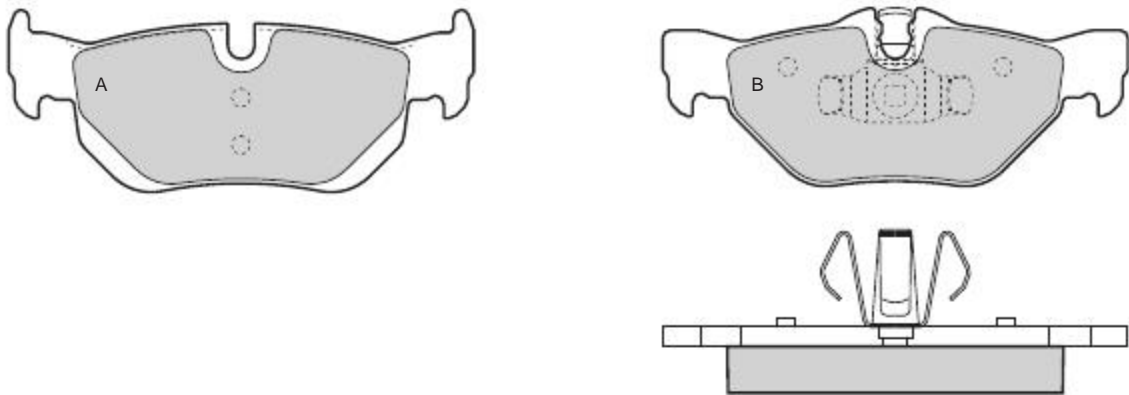



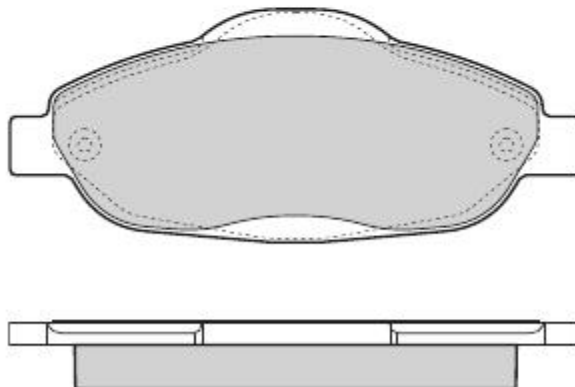



<b>1363</b>	BMW	ATE	X	123	A 48,1 B 47,9	17,3	2A-2B		
-------------	-----	-----	---	-----	------------------	------	-------	--	--



<b>1364</b>	PEUGEOT	BOSCH	X	151	61,5	18	4		
-------------	---------	-------	---	-----	------	----	---	--	--



									
<b>1365</b>	IVECO	BREMBO	X	184	64,6	22,7	4		

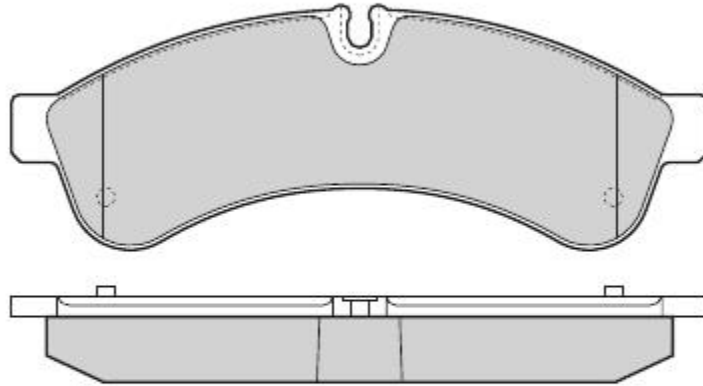



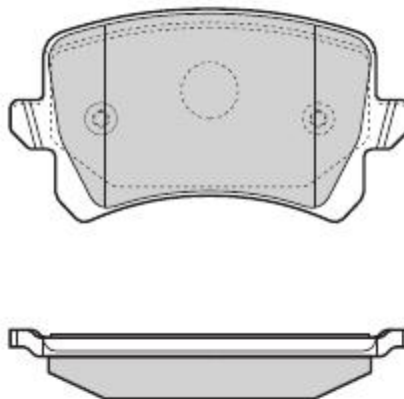



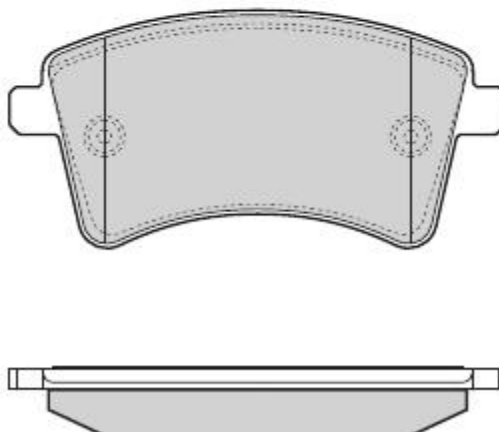



<b>1366</b>	AUDI - SEAT - VOLKSWAGEN	LUCAS	X	105,4	56,4	17	4		
-------------	--------------------------	-------	---	-------	------	----	---	--	--



<b>1367</b>	RENAULT	LUCAS	X	131,2	62,4	18,5	4		
-------------	---------	-------	---	-------	------	------	---	--	--



									
1368	RENAULT	LUCAS	X	95,4	43,9	16	4		

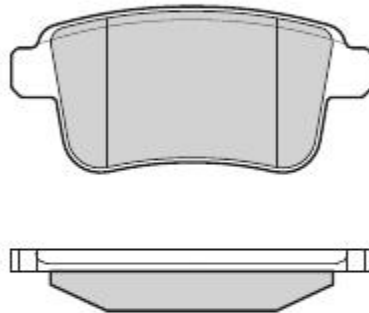

1369	HONDA	ATE	X	154,8	A 55 B-C 62,2	18	2A 1B-1C		
------	-------	-----	---	-------	------------------	----	-------------	--	--

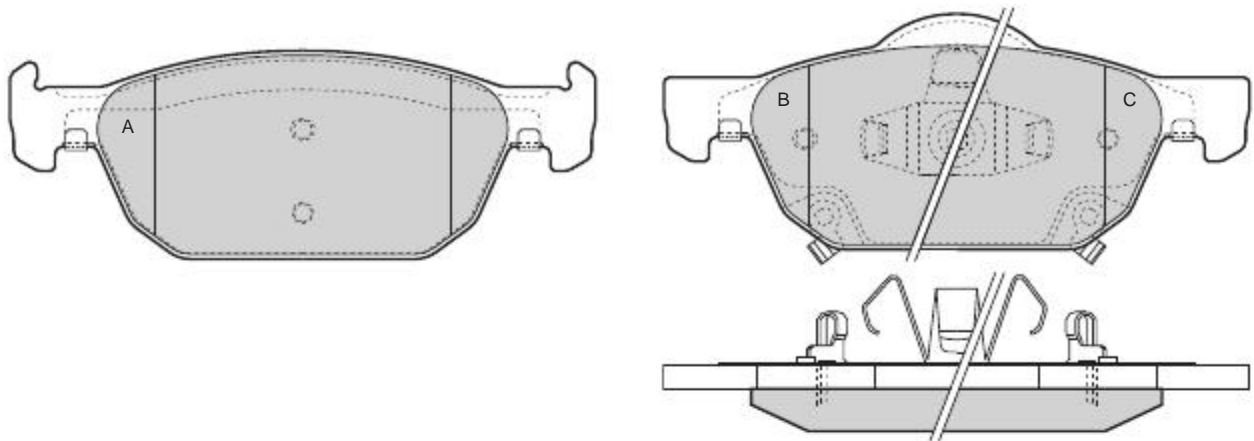

1370	HONDA	NISSIN	X	93,4	47	14,8	2A 1B-1C		
------	-------	--------	---	------	----	------	-------------	--	--

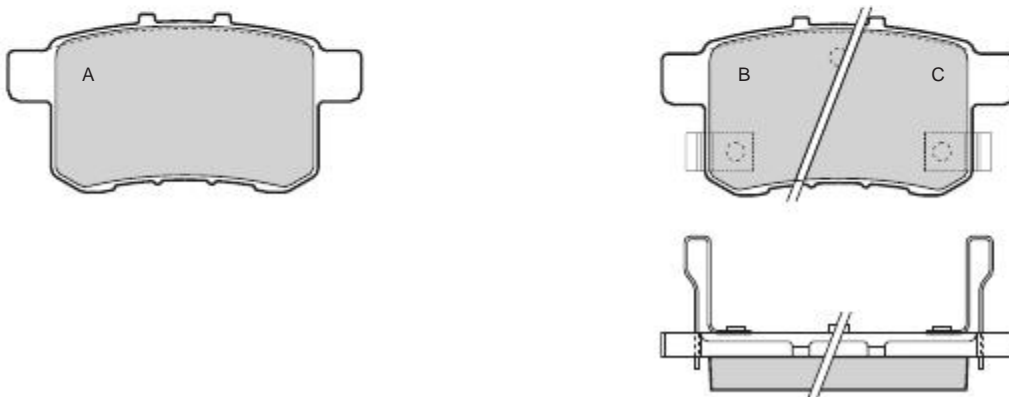



<b>1371</b>	BMW	ATE	X	A 170 B 171,2	76,8	A 20,3 B 19,8	2A-2B		

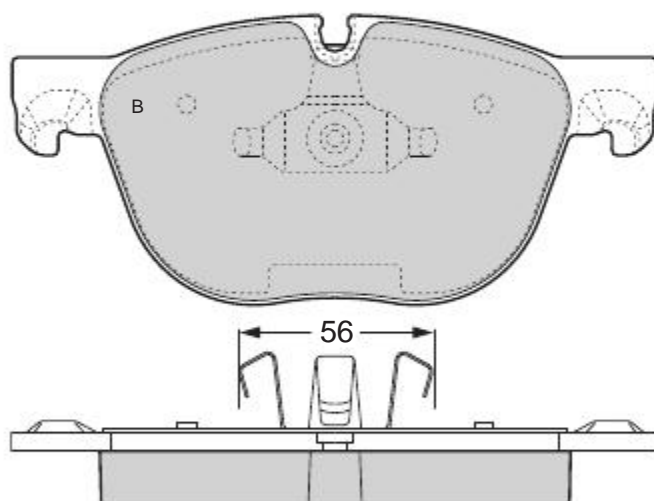
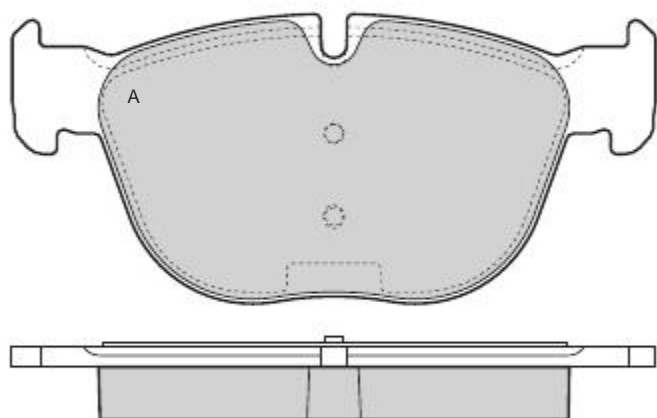

<b>1372</b>	VOLKSWAGEN	ATE	X	A 141,4 B-C 140,6	A 50,8 B-C 53,8	19,1	2A 1B-1C	1	310
-------------	------------	-----	---	----------------------	--------------------	------	-------------	---	-----

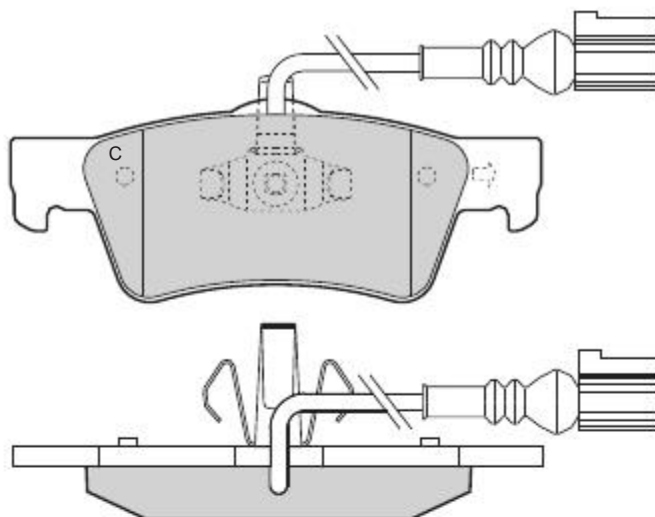
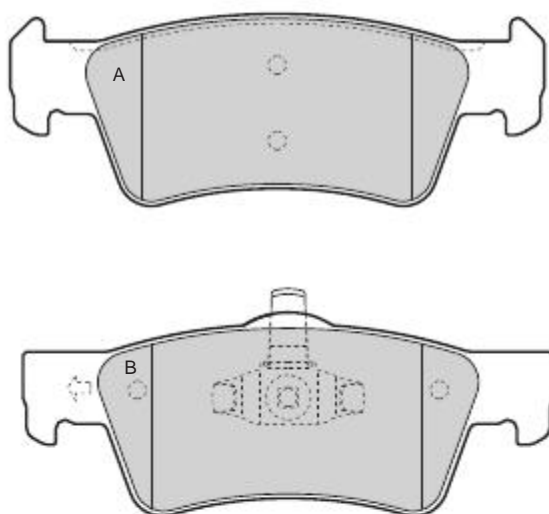



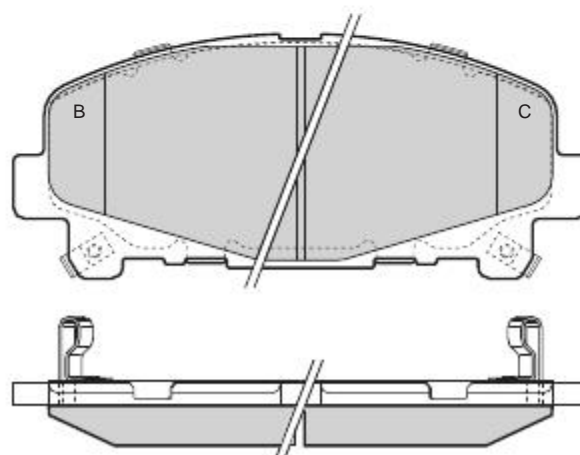
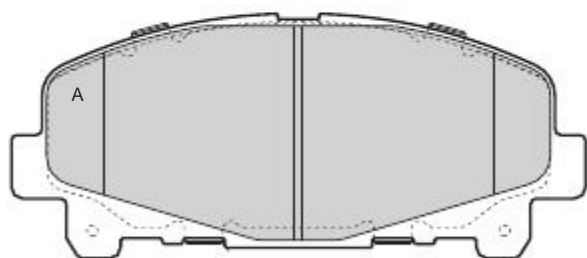







<b>1373</b>	HONDA	AKEBONO	X	151,8	64,8	17	2A 1B-1C		
-------------	-------	---------	---	-------	------	----	-------------	--	--



Reference in this Catalogue to other manufacturers and to part numbers and other descriptions are for identification purposes only, because the above **DISC BRAKE PADS** are **NOT ORIGINAL** but with these interchangeable



									
<b>1374</b>	HONDA	AKEBONO	X	88,8	47,5	15,3	2A 1B-1C		

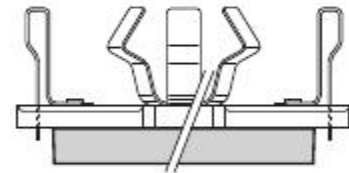
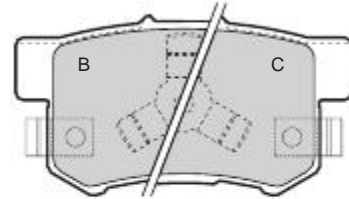
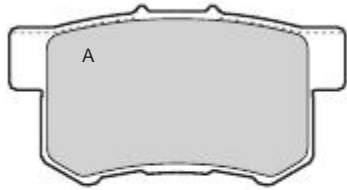



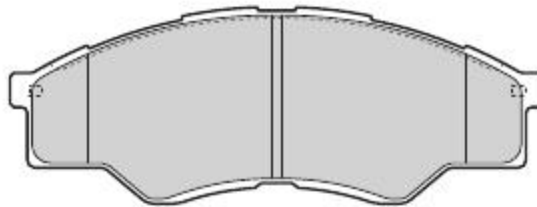



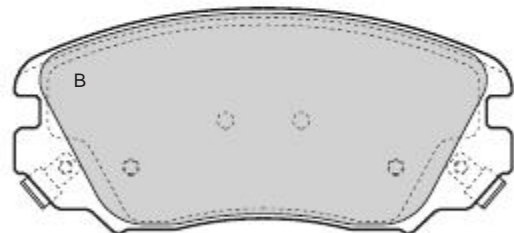



<b>1375</b>	TOYOTA	ADVICS	X	140,1	52	16	4		
-------------	--------	--------	---	-------	----	----	---	--	--



<b>1376</b>	OPEL	MANDO	X	131,5	59,6	19,3	2A-2B		
-------------	------	-------	---	-------	------	------	-------	--	--



									
<b>1377</b>	OPEL - SAAB	MANDO	X	141,9	66,7	19,3	2A 1B-1C		

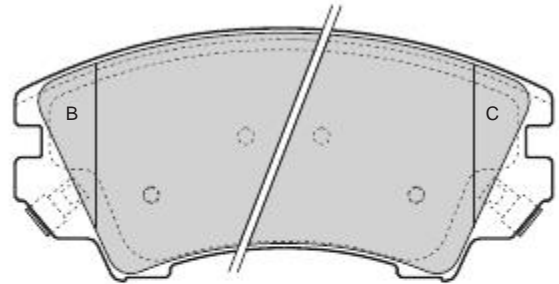
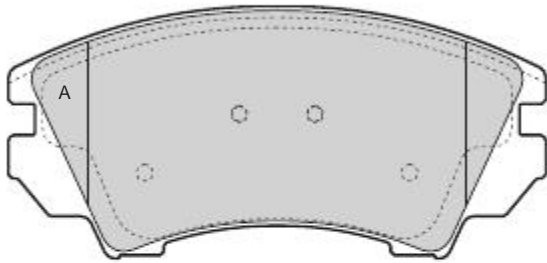



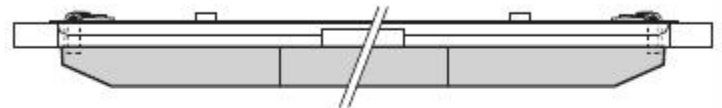
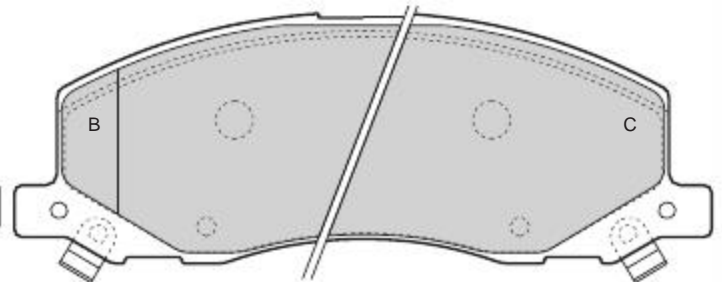
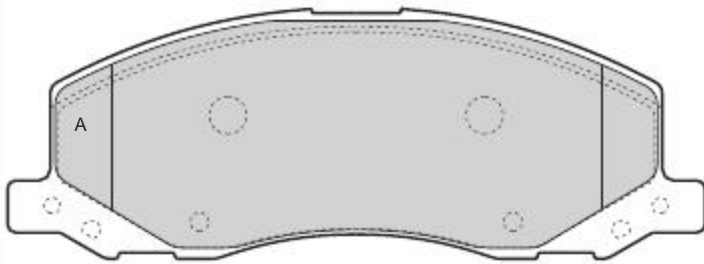



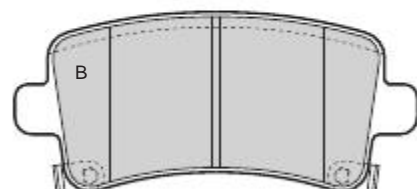
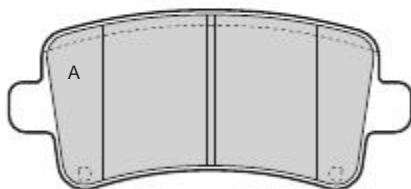



<b>1378</b>	OPEL - SAAB	TRW	X	184,6	66,5	17,3	2A 1B-1C		
-------------	-------------	-----	---	-------	------	------	-------------	--	--



<b>1379</b>	OPEL - SAAB	TRW	X	106,4	47,4	17,4	2A-2B		
-------------	-------------	-----	---	-------	------	------	-------	--	--



									
<b>1380</b>	CITROEN - MITSUBISHI PEUGEOT - SUZUKI	AKEBONO	X	108,7	42,5	14,6	4		

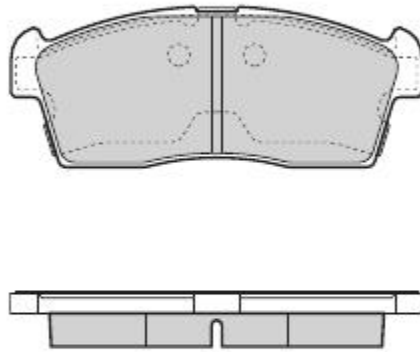



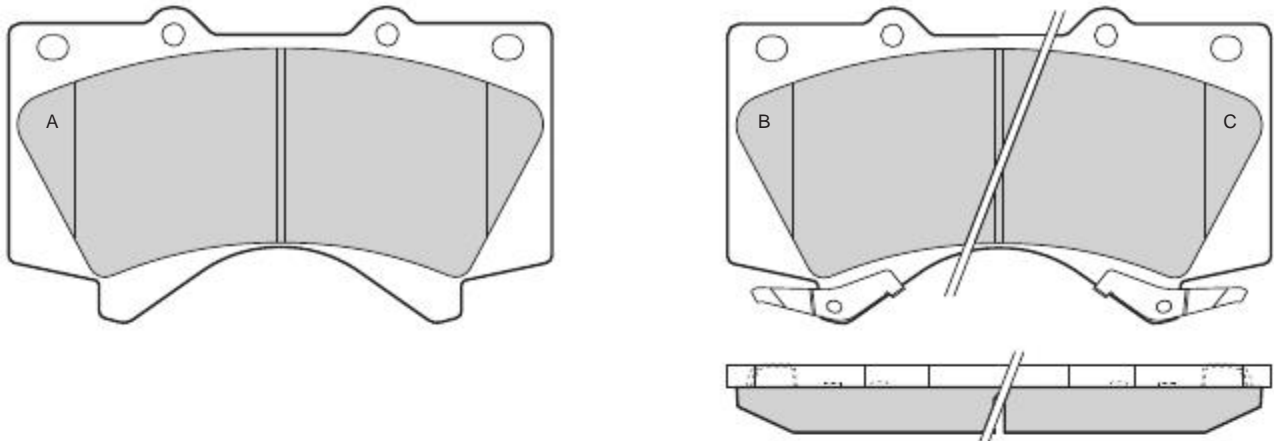



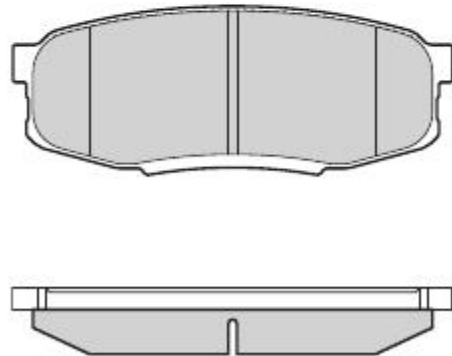

<b>1381</b>	TOYOTA	ADVICS	X	143,6	83,4	17,9	2A 1B-1C		
-------------	--------	--------	---	-------	------	------	-------------	--	--



<b>1382</b>	TOYOTA	ADVICS	X	116,2	44,7	17,3	4		
-------------	--------	--------	---	-------	------	------	---	--	--

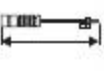

									
<b>1383</b>	RENAULT	ATE	X	155,2	A 68,2 B 63	18	2A-2B		

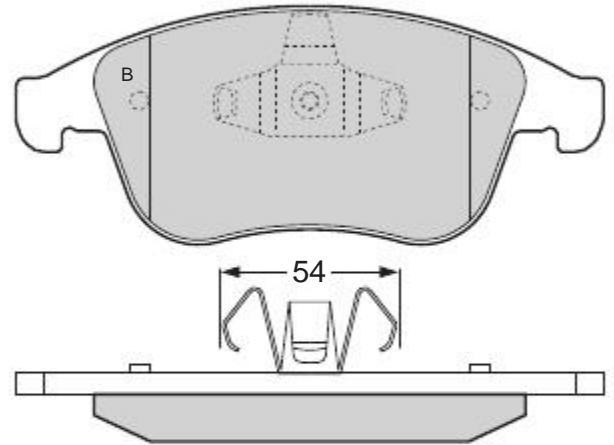
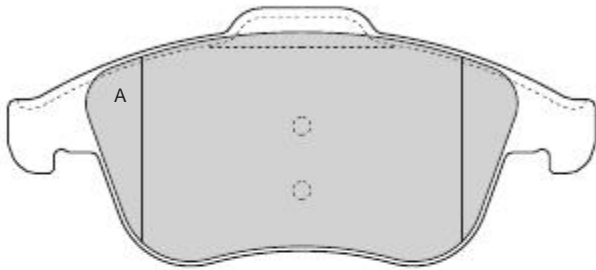



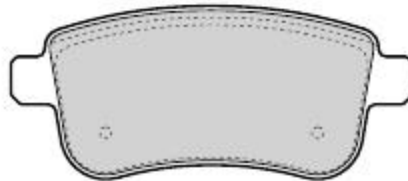



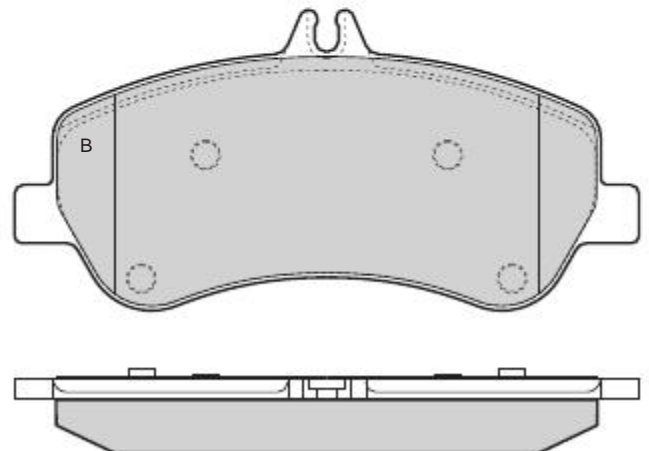
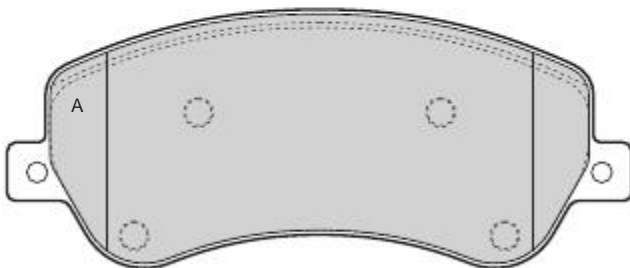

<b>1384</b>	RENAULT	TRW	X	106,1	45,8	16	4		
-------------	---------	-----	---	-------	------	----	---	--	--



<b>1385</b>	MERCEDES	BOSCH	X	165,1	A 68,3 B 79,4	20,3	2A-2B		
-------------	----------	-------	---	-------	------------------	------	-------	--	--

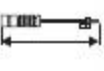

									
<b>1386</b>	CITROEN - PEUGEOT	TRW	X	87	52,9	17	4		

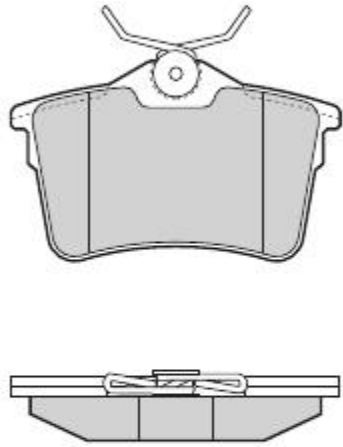



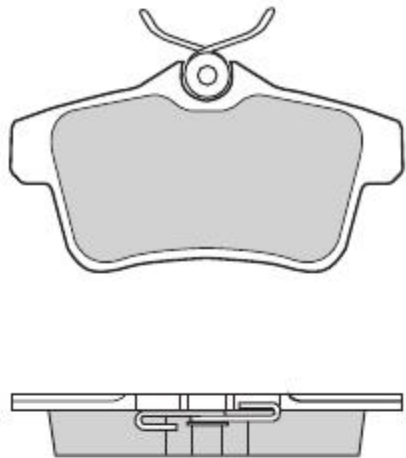



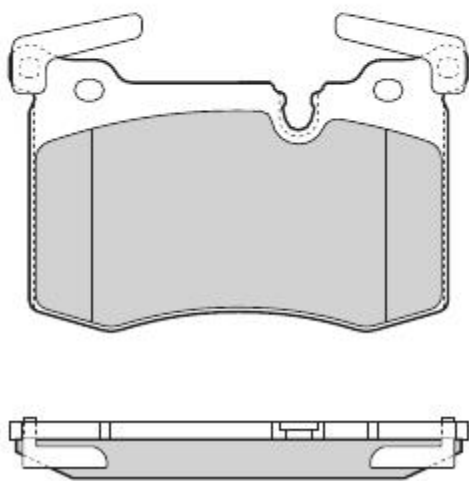

<b>1387</b>	CITROEN - PEUGEOT	TRW	X	103,8	56,1	17,5	4		
-------------	-------------------	-----	---	-------	------	------	---	--	--



<b>1388</b>	MINI (BMW)	BREMBO	X	121	75,7	14,8	4		
-------------	------------	--------	---	-----	------	------	---	--	--

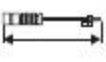

									
1389	CHRYSLER	BOSCH	X	150,6	56,4	18,8	4		

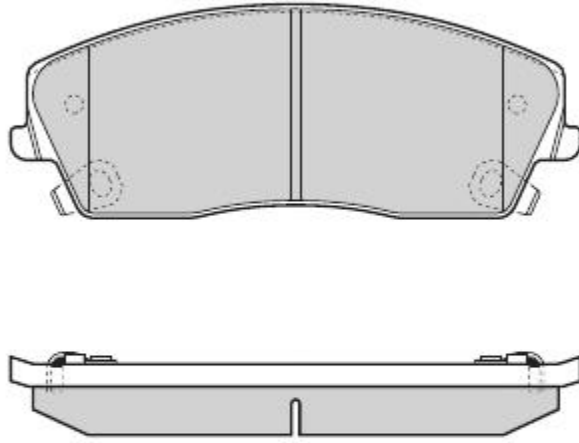



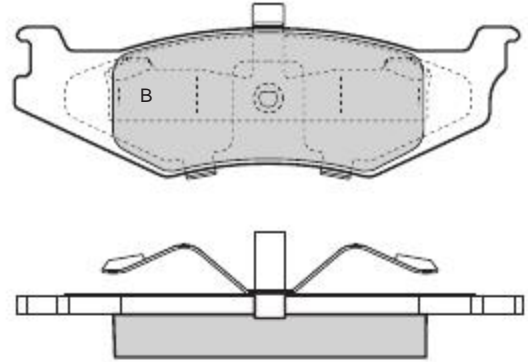
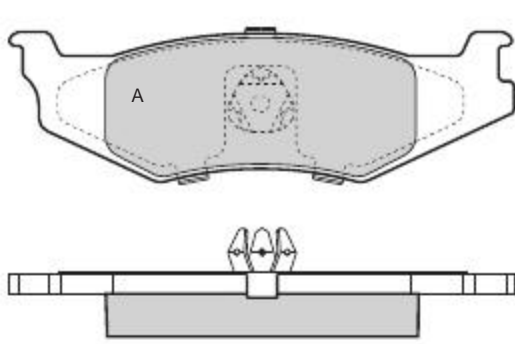



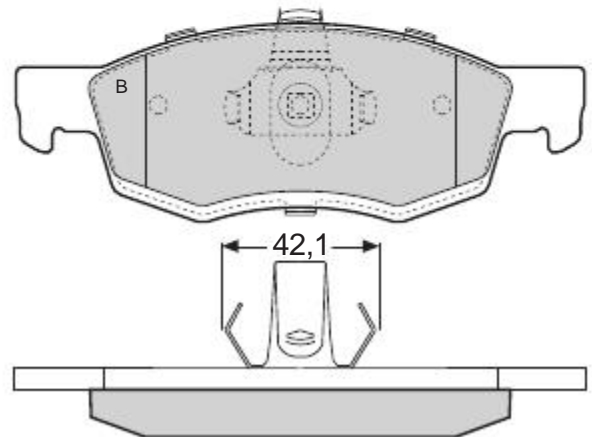
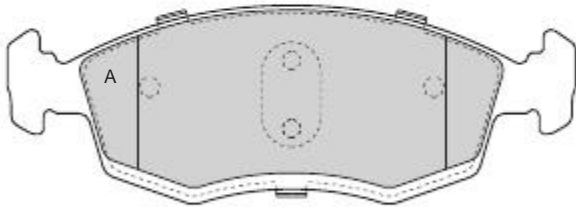

1390	CHRYSLER	KELSEY-HAYES	X	133,6	A 41,3 B 46,4	15	2A-2B		
------	----------	--------------	---	-------	------------------	----	-------	--	--



1391	DACIA - RENAULT	ATE	X	150,2	52,5	18	2A-2B		
------	-----------------	-----	---	-------	------	----	-------	--	--

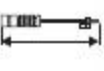

									
<b>1392</b>	<b>DACIA - RENAULT</b>	<b>ATE</b>	<b>X</b>	<b>155,2</b>	<b>A 64,5 B 59,4</b>	<b>18</b>	<b>2A-2B</b>		

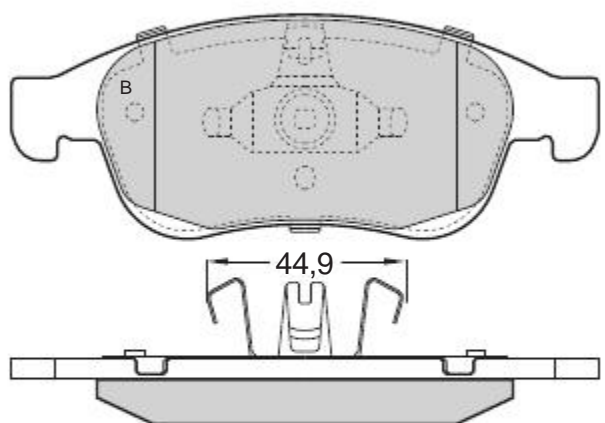



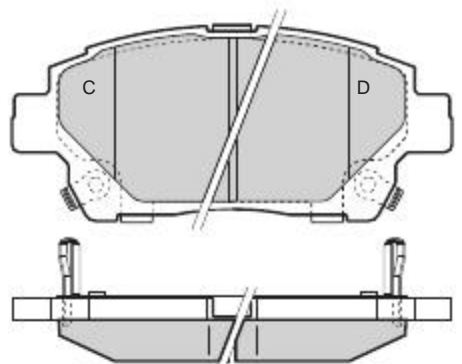
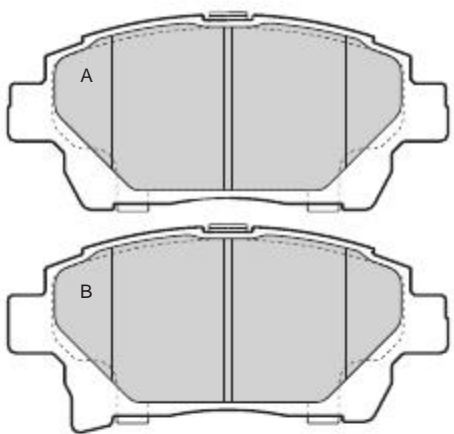



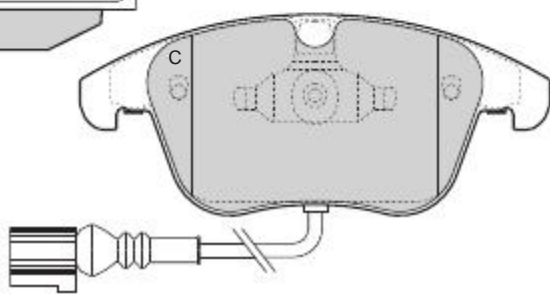
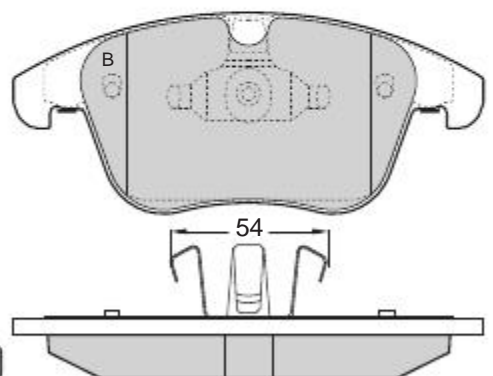
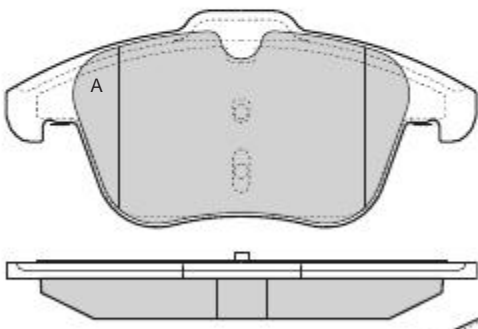



<b>1393</b>	<b>TOYOTA</b>	<b>ADVICS</b>	<b>X</b>	<b>116,3</b>	<b>51,6</b>	<b>16,5</b>	<b>1A-1B 1C-1D</b>		
-------------	---------------	---------------	----------	--------------	-------------	-------------	------------------------	--	--



<b>1394</b>	<b>SEAT - VOLKSWAGEN</b>	<b>ATE</b>	<b>X</b>	<b>155,2</b>	<b>A 71,6 B-C 66,4</b>	<b>A19,7 B-C 20,7</b>	<b>2A 1B-1C</b>	<b>1</b>	<b>155</b>
-------------	--------------------------	------------	----------	--------------	----------------------------	---------------------------	---------------------	----------	------------



									
<b>1395</b>	NISSAN - SUZUKI	AKEBONO	X	105,5	39	14,2	3A	1B	

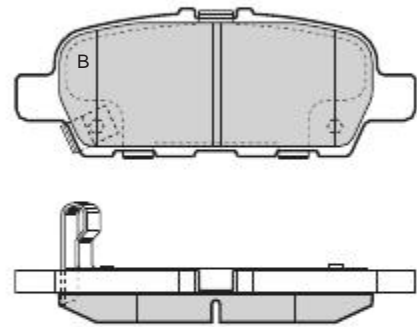
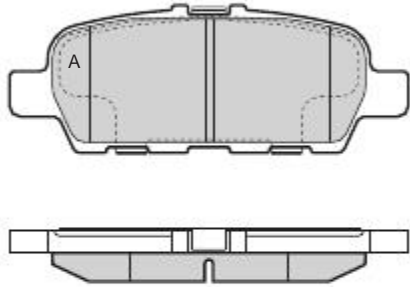



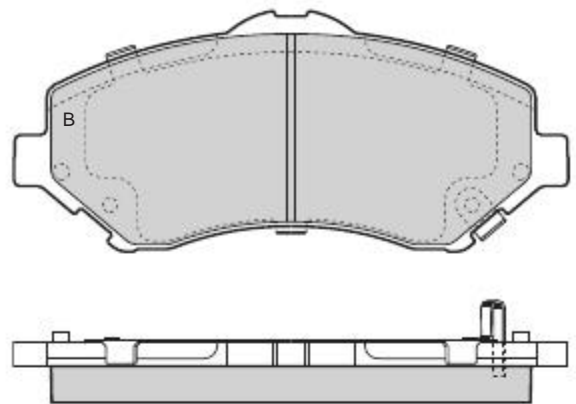
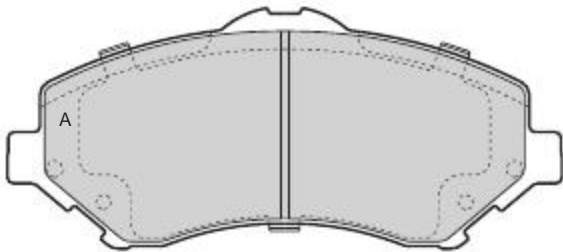



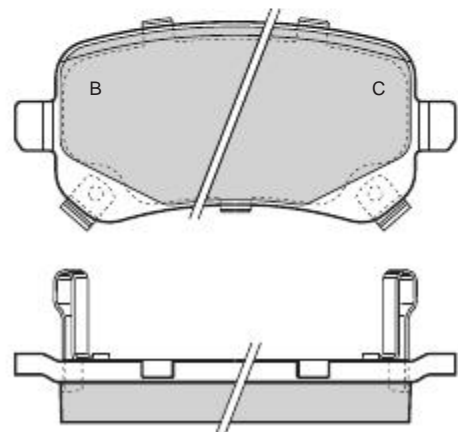
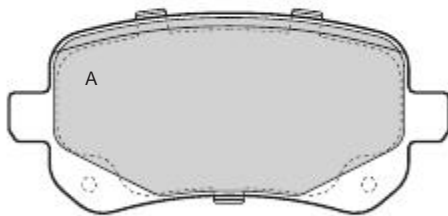

<b>1396</b>	CHRYSLER - DODGE FIAT - JEEP	BOSCH	X	146,5	64	16,5	2A-2B		
-------------	---------------------------------	-------	---	-------	----	------	-------	--	--



<b>1397</b>	CHRYSLER - DODGE - FIAT	LUCAS	X	116,3	52,9	16,8	2A	1B-1C	
-------------	-------------------------	-------	---	-------	------	------	----	-------	--



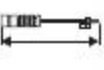

									
<b>1398</b>	JEEP		X	116,6	45,4	16,8	2A-2B		

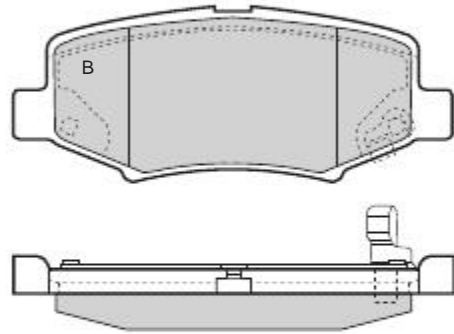
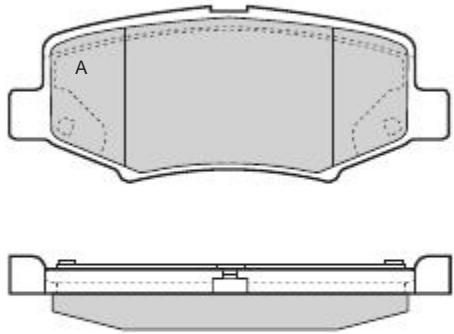



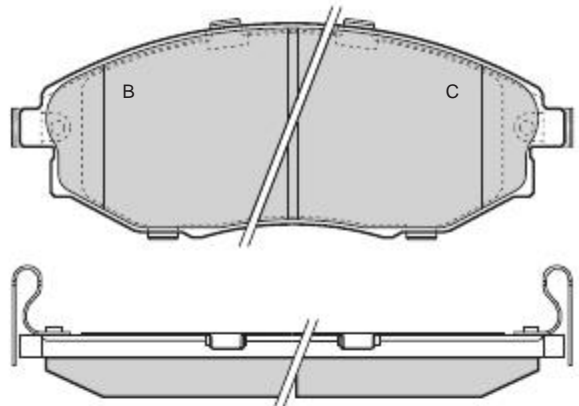
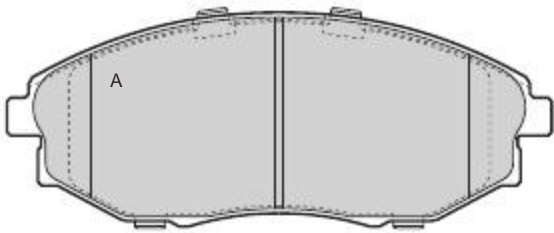



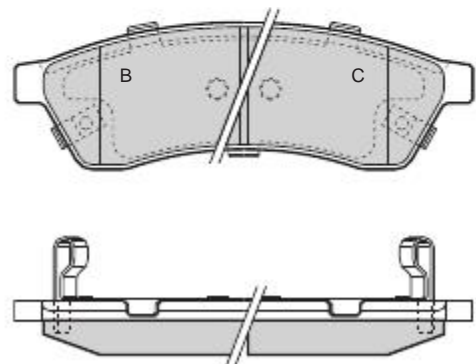
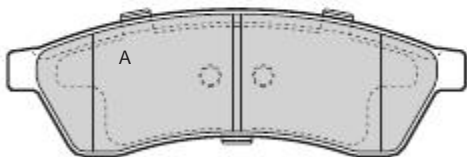



<b>1399</b>	CHEVROLET	AKEBONO	X	144	56,5	17	2A 1B-1C		
-------------	-----------	---------	---	-----	------	----	-------------	--	--



<b>1400</b>	CHEVROLET	BREMBO	X	121	38,8	14,8	2A 1B-1C		
-------------	-----------	--------	---	-----	------	------	-------------	--	--



									
<b>1401</b>	HYUNDAI	MANDO	X	131,5	60,2	17,5	2A 1B-1C		

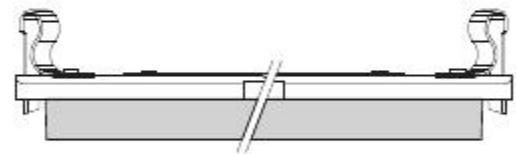
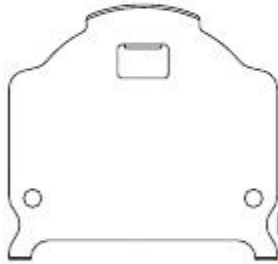
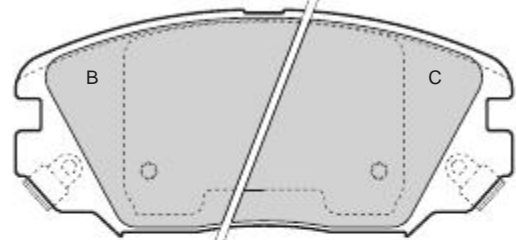
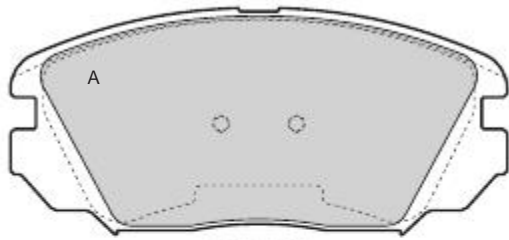





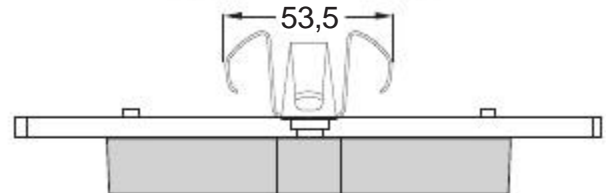
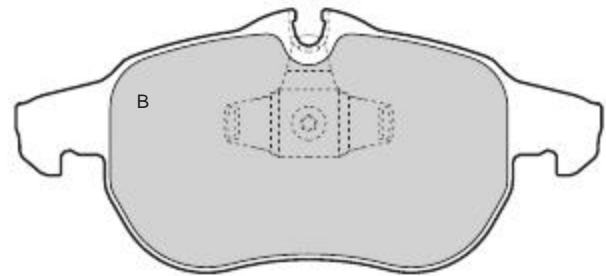
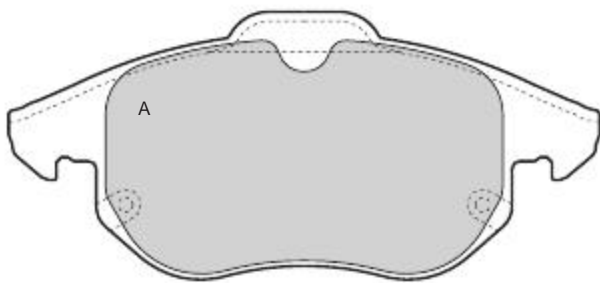



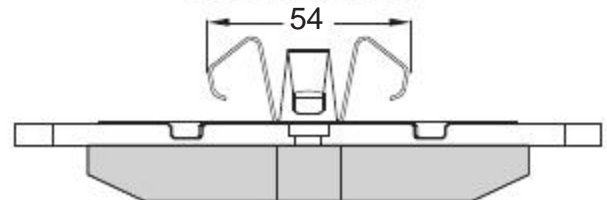
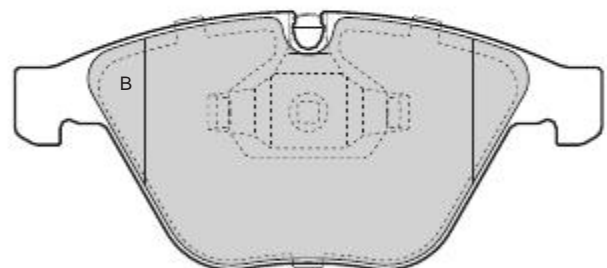

OPTIONAL

<b>1402</b>	FIAT	ATE	X	A 156,3 B 155	A 70,7 B 69,6	20,3	2A-2B		
-------------	------	-----	---	------------------	------------------	------	-------	--	--



<b>1403</b>	BMW	ATE	X	155,1	68,5	20,3	2A-2B		
-------------	-----	-----	---	-------	------	------	-------	--	--



									
<b>1404</b>	CHEVROLET - OPEL	BOSCH	X	148	60,4	19	2A 1B-1C		

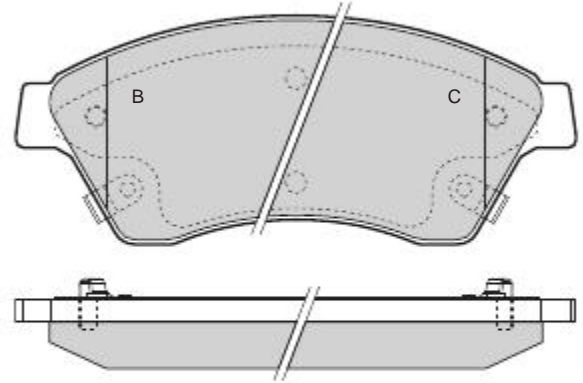
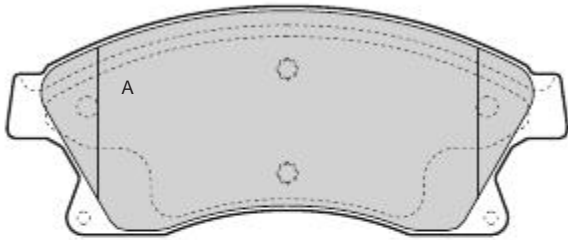

**1405**

CHEVROLET - OPEL

BOSCH

X

148,1

61,2

19

2A  
1B-1C

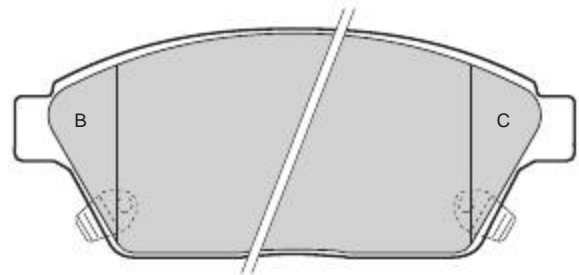
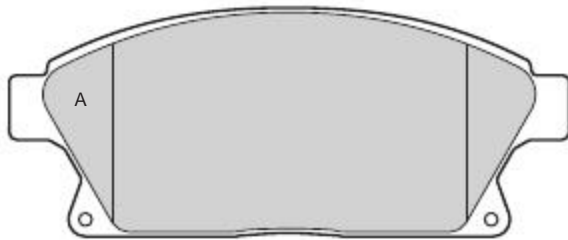

**1406**

CHEVROLET - OPEL

BOSCH

X

116,8

42,8

16,3

2A  
1B-1C

