

<b>1407</b>	OPEL	BOSCH	X	150,8	54,9	19,5	3A-1B		

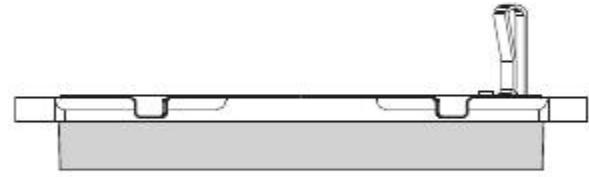

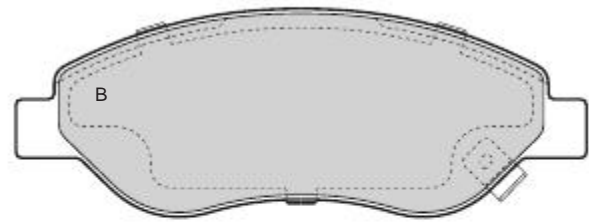

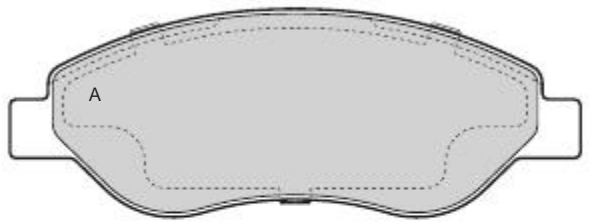

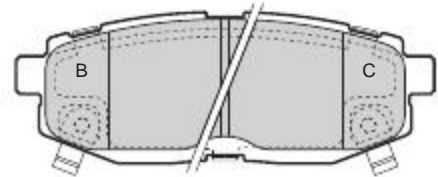
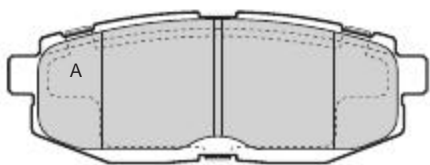
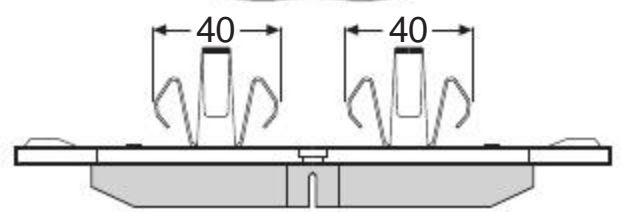
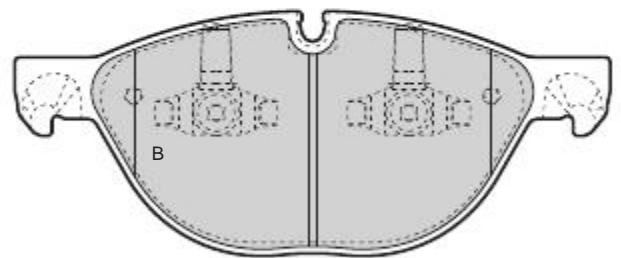
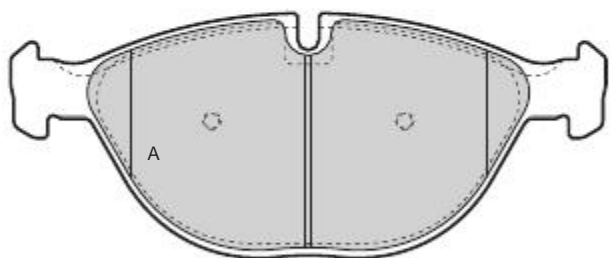





<b>1408</b>	SUBARU	NBK	X	110,5	40	16	2A 1B-1C		
-------------	--------	-----	---	-------	----	----	-------------	--	--



<b>1409</b>	BMW	ATE	X	193	79,3	A 20,7 B 19,7	2A-2B		
-------------	-----	-----	---	-----	------	------------------	-------	--	--



									
1410	BMW	ATE	X	139.7	67.9	17.3	2A-2B		

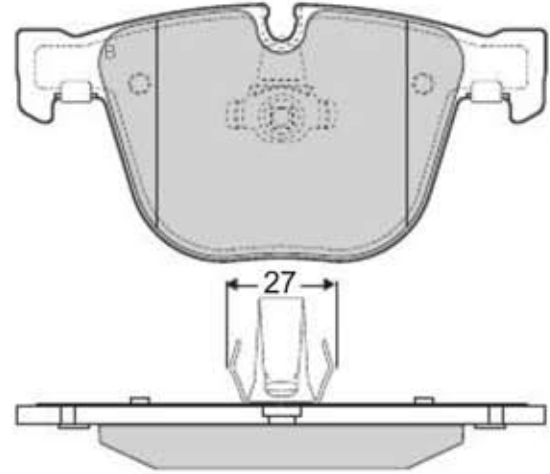
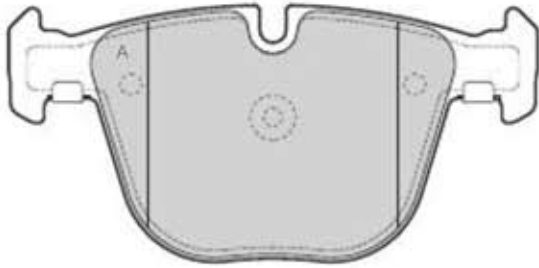



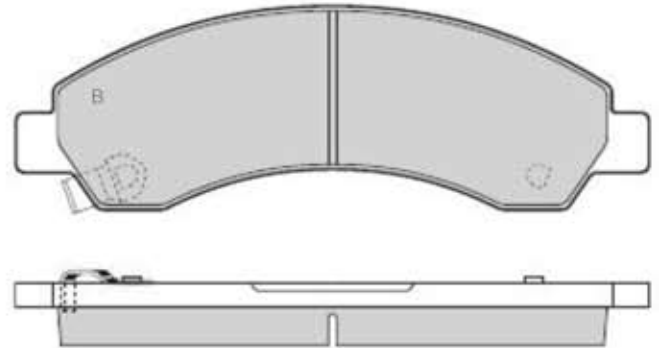
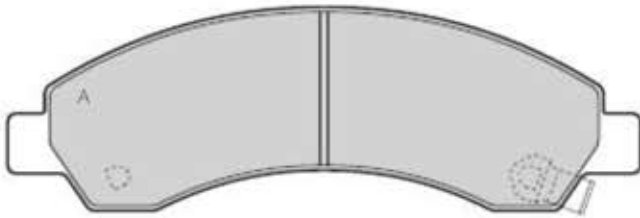



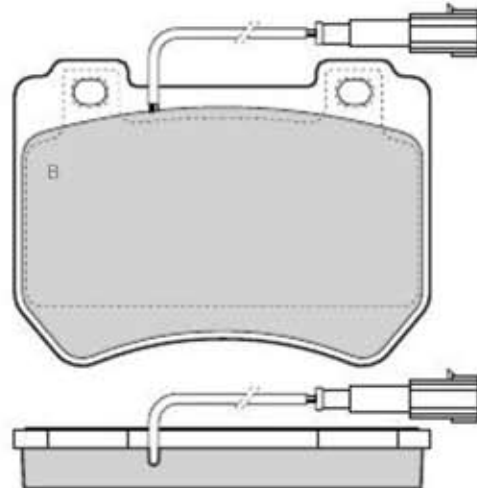
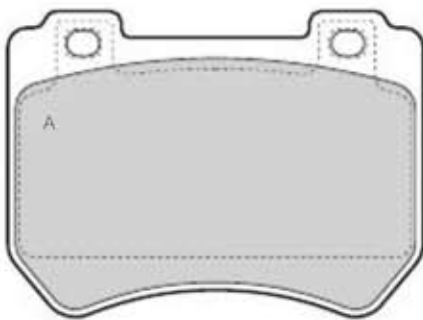



1411	GREAT WALL	SUMITOMO	X	167.3	53.8	16.5	2A-2B		
------	------------	----------	---	-------	------	------	-------	--	--



1412	ALFA ROMEO	BREMBO	X	109.8	80.8	15.8	3A-1B		180
------	------------	--------	---	-------	------	------	-------	--	-----



									
1416	LAND ROVER	TRW	X	116,6	63	7,1	4		

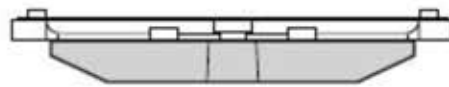
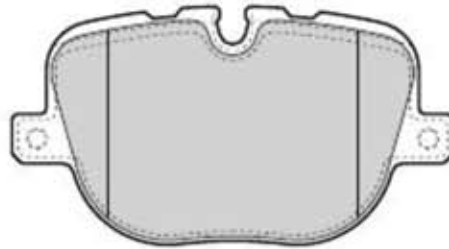



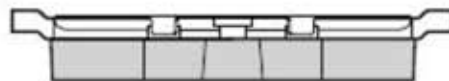



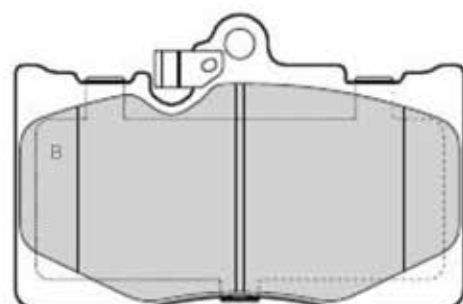
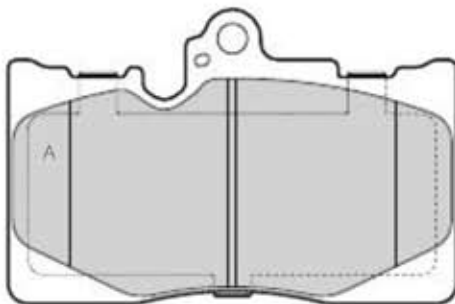



1417	LAND ROVER	TRW	X	116,5	46,5	7,1	4		
------	------------	-----	---	-------	------	-----	---	--	--



1418	LEXUS	SUMITOMO	X	118,5	77,7	17,5	2A-2B		
------	-------	----------	---	-------	------	------	-------	--	--



									
1413	FIAT - LANCIA	ATE	X	A 156,4 B-C 155,2	A 71,5 B-C 69	20,3	2A 1B-1C	1+1	215

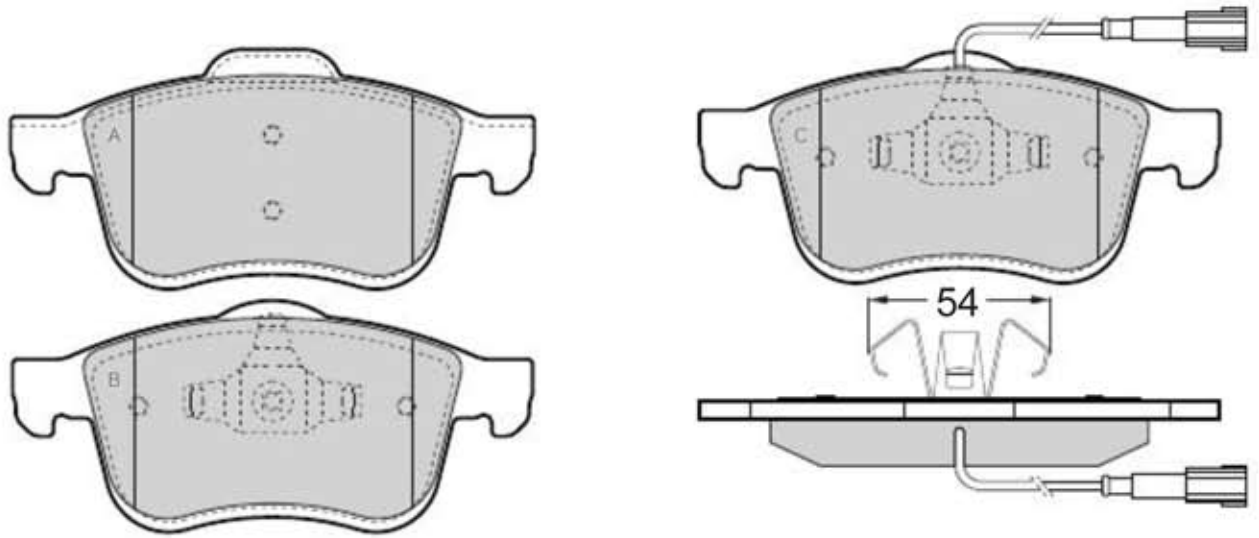



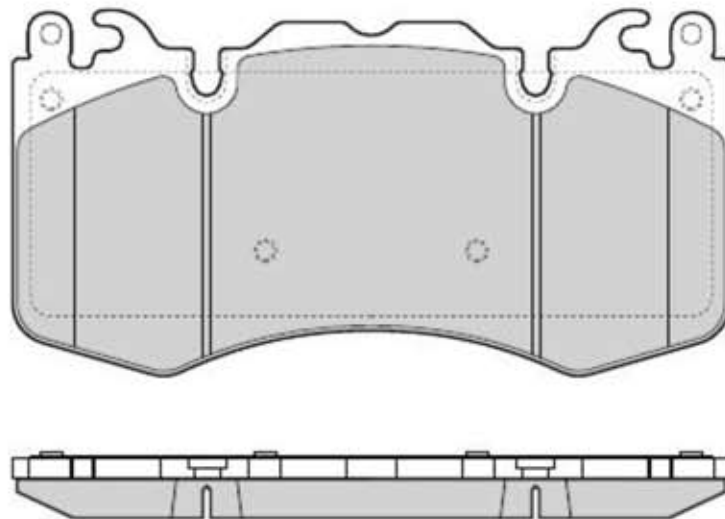



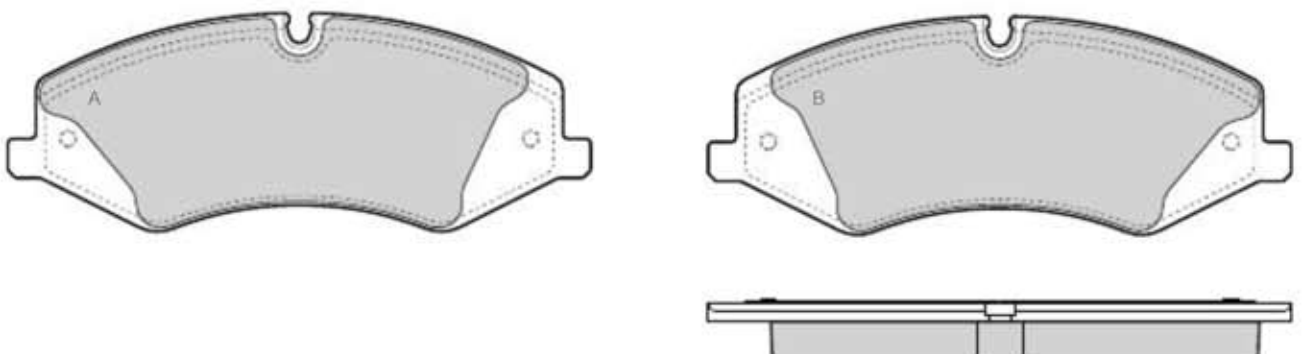

1414	LAND ROVER	BREMBO	X	189,6	96	16,6	4		
------	------------	--------	---	-------	----	------	---	--	--



1415	LAND ROVER	TRW	X	192,6	72,1	18,5	2 A - 2 B		
------	------------	-----	---	-------	------	------	-----------	--	--

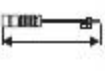

									
<b>1419</b>	BMW	BREMBO	X	129,4	114	19,5	4		

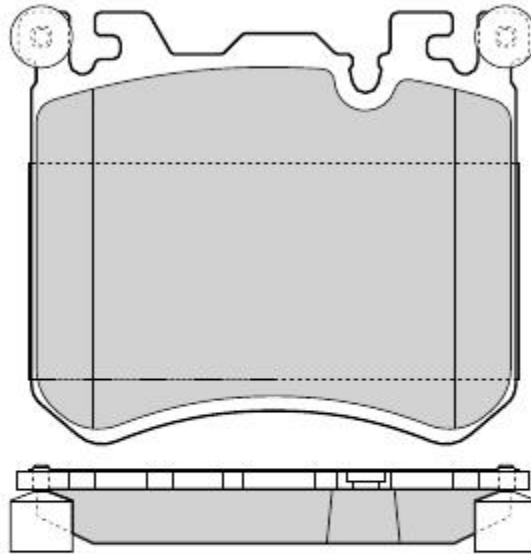







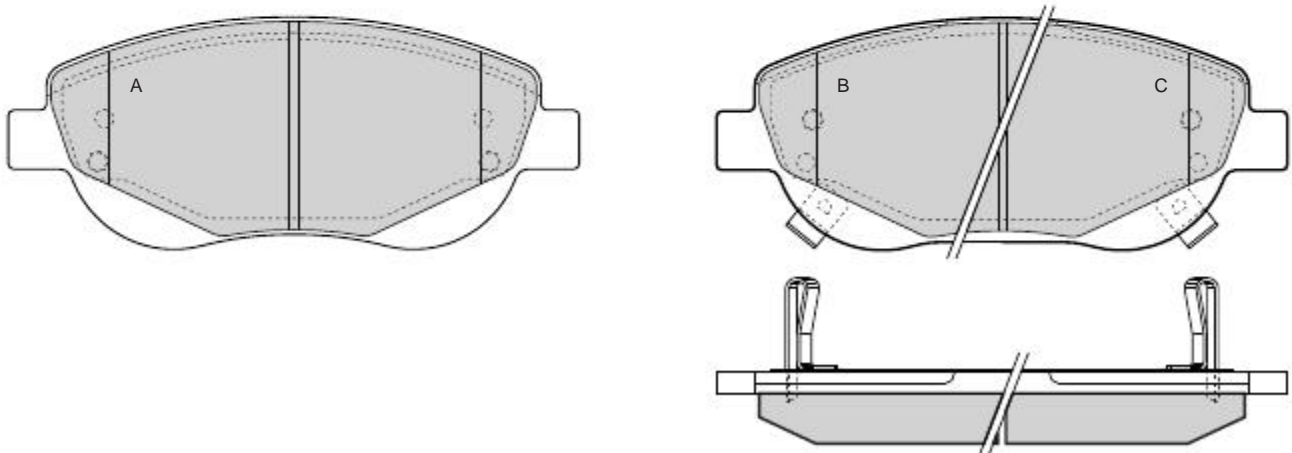



<b>1420</b>	LEXUS	NBK	X	88	58,2	15,5	2A 1B-1C		
-------------	-------	-----	---	----	------	------	-------------	--	--



<b>1421</b>	TOYOTA	BOSCH	X	150,9	61,3	19,5	2A 1B-1C		
-------------	--------	-------	---	-------	------	------	-------------	--	--



									
<b>1422</b>	TOYOTA	BOSCH	X	150,8	A 62,5 B-C 65,3	19,5	2A 1B-1C		

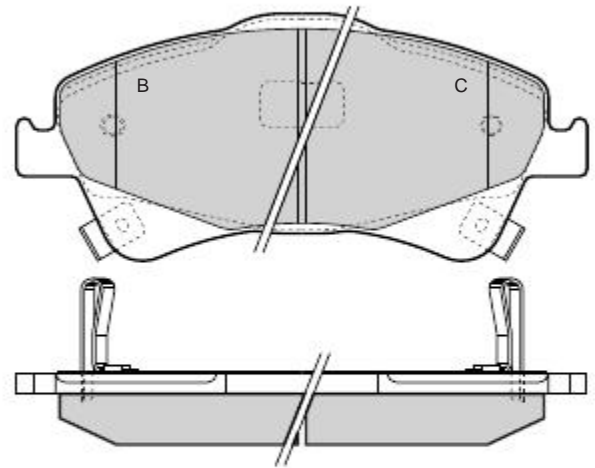
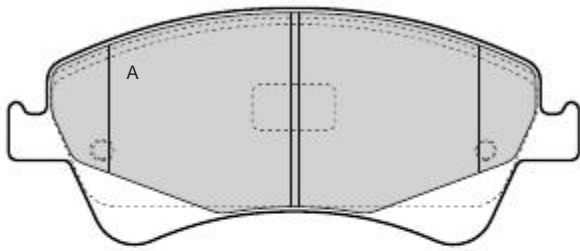



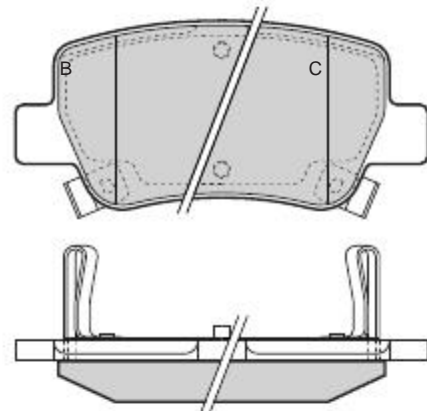
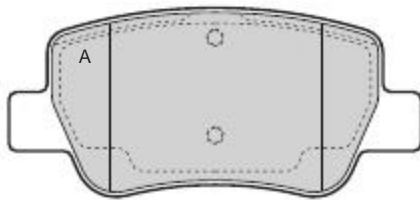



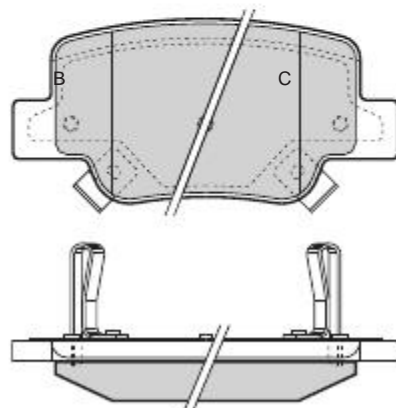
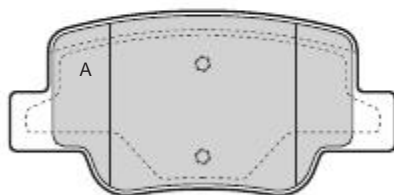



<b>1423</b>	TOYOTA	BOSCH	X	109	49,9	17	2A 1B-1C		
-------------	--------	-------	---	-----	------	----	-------------	--	--



<b>1424</b>	TOYOTA	BOSCH	X	101,8	48,7	16,5	2A 1B-1C		
-------------	--------	-------	---	-------	------	------	-------------	--	--



									
<b>1425</b>	FIAT	BOSCH	X	122,8	53,6	17,8	2 A- 2 B	2+2	220

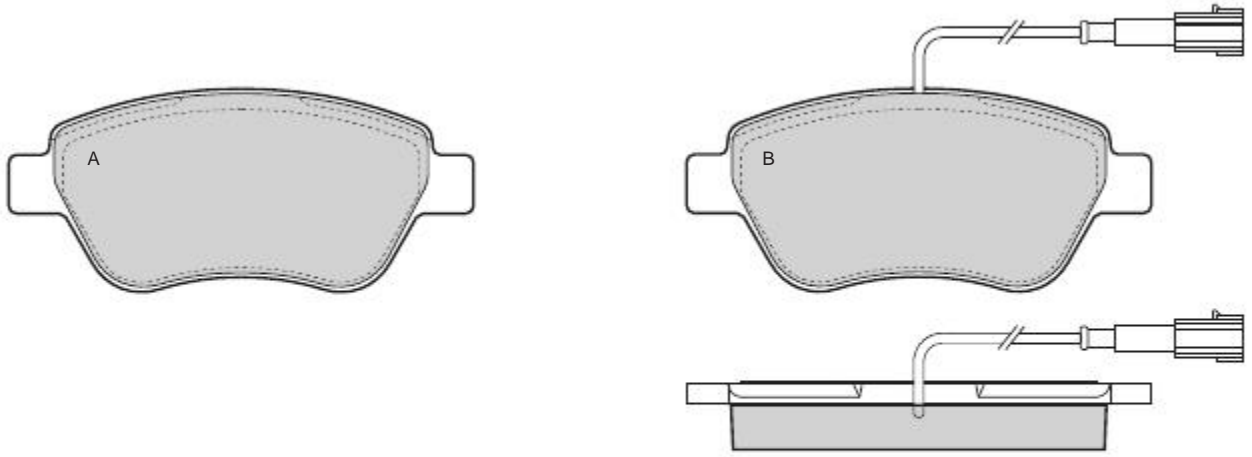



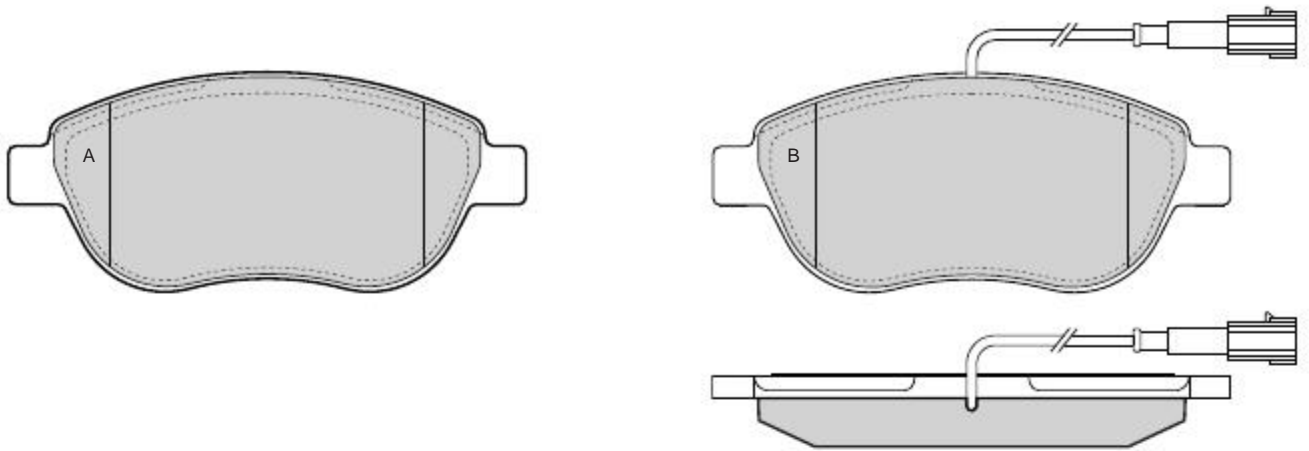



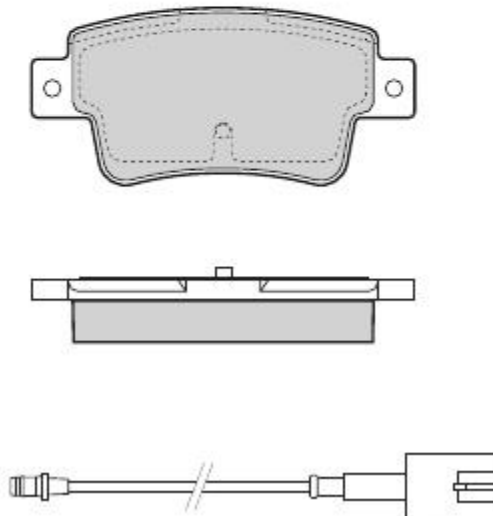



<b>1426</b>	FIAT	BOSCH	X	136,8	57,9	19,2	2 A- 2 B	2+2	220
-------------	------	-------	---	-------	------	------	----------	-----	-----



<b>1427</b>	FIAT	BOSCH	X	101,9	47,5	17,2	4	4+2	165
-------------	------	-------	---	-------	------	------	---	-----	-----



									
<b>1428</b>	CITROEN	BOSCH	X	136,8	59,2	18,5	4		

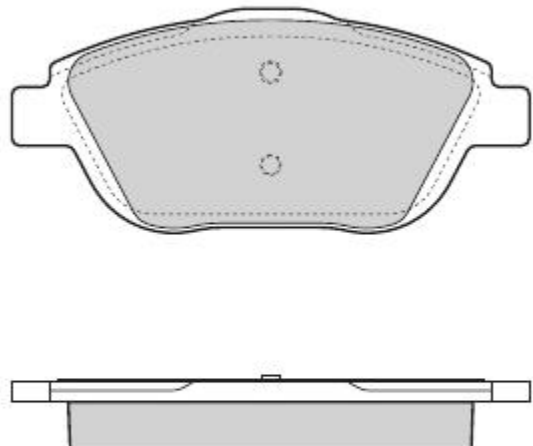



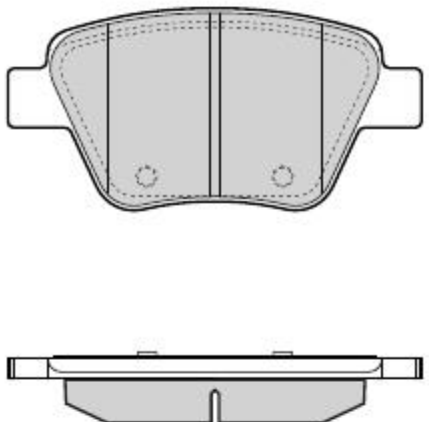



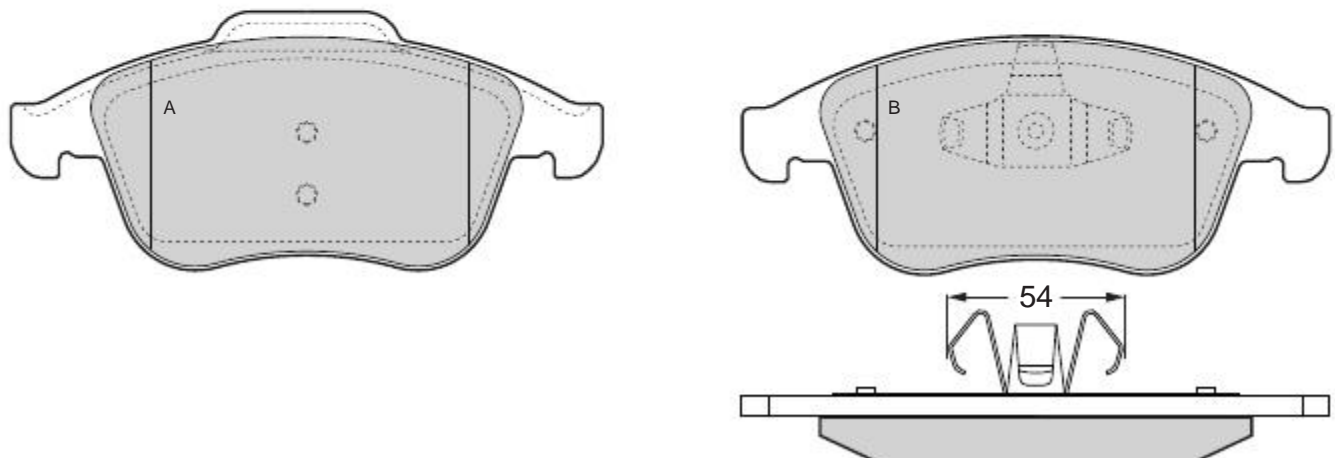

<b>1429</b>	AUDI - SEAT - SKODA VOLKSWAGEN	BOSCH	X	109,3	53,4	17,7	4		
-------------	-----------------------------------	-------	---	-------	------	------	---	--	--



<b>1430</b>	RENAULT	ATE	X	A 156,3 B 155,2	A 68,3 B 63	18	2 A- 2 B		
-------------	---------	-----	---	--------------------	----------------	----	----------	--	--



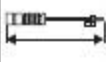

									
1431	RENAULT	ATE	X	A 156,3 B 155,2	A 68,3 B 63	18	2 A- 2 B		

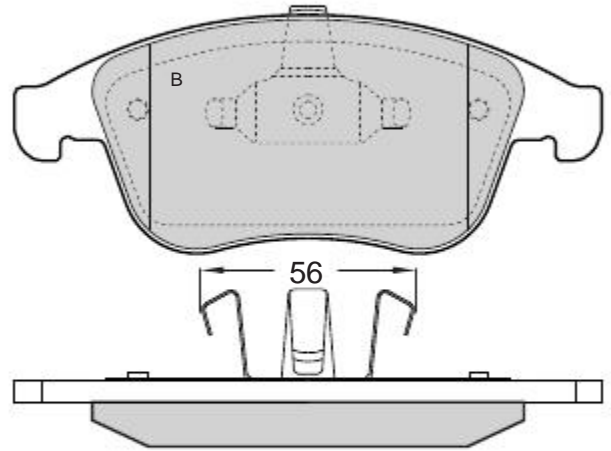
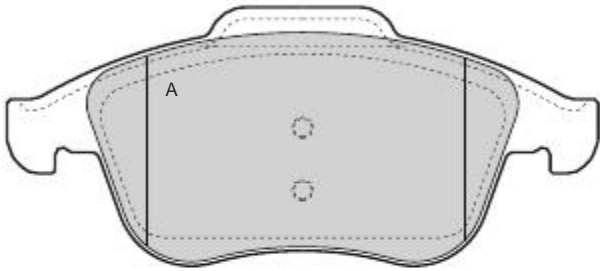



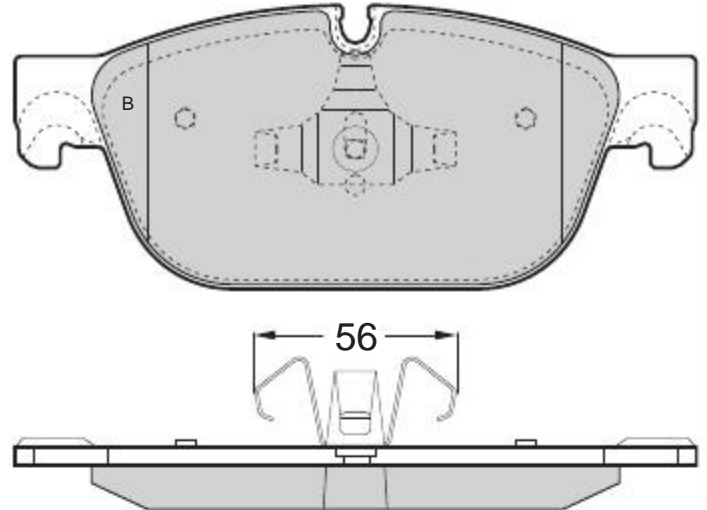



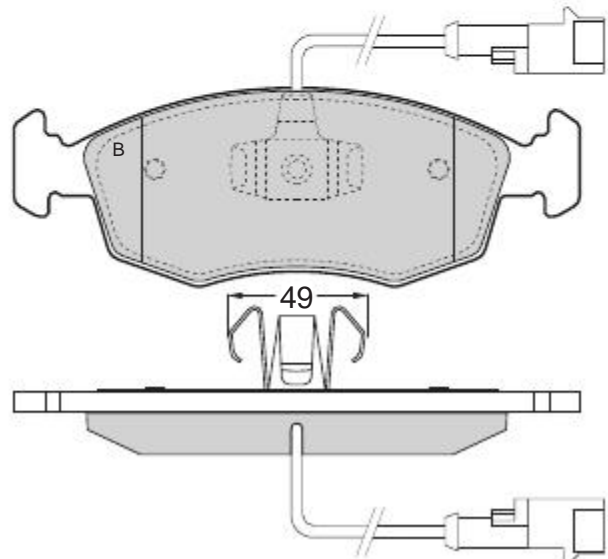
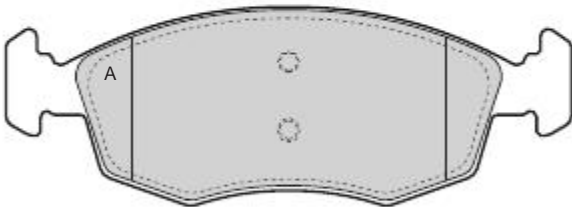



1432	CITROEN - PEUGEOT	ATE	X	180,2	75	17	2 A- 2 B		
------	-------------------	-----	---	-------	----	----	----------	--	--



1433	FIAT	ATE	X	149,5	52,5	17,2	2A-2B	2+2	210
------	------	-----	---	-------	------	------	-------	-----	-----



									
<b>1434</b>	ROVER - TATA	TRW	X	121,4	45,3	16	4		

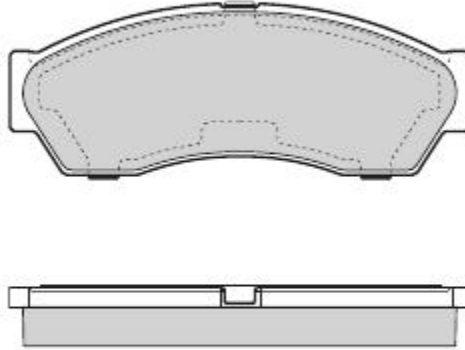



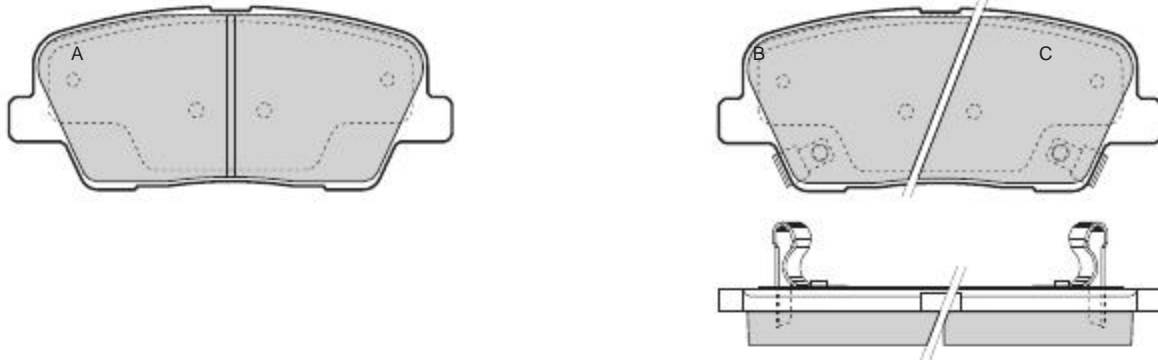



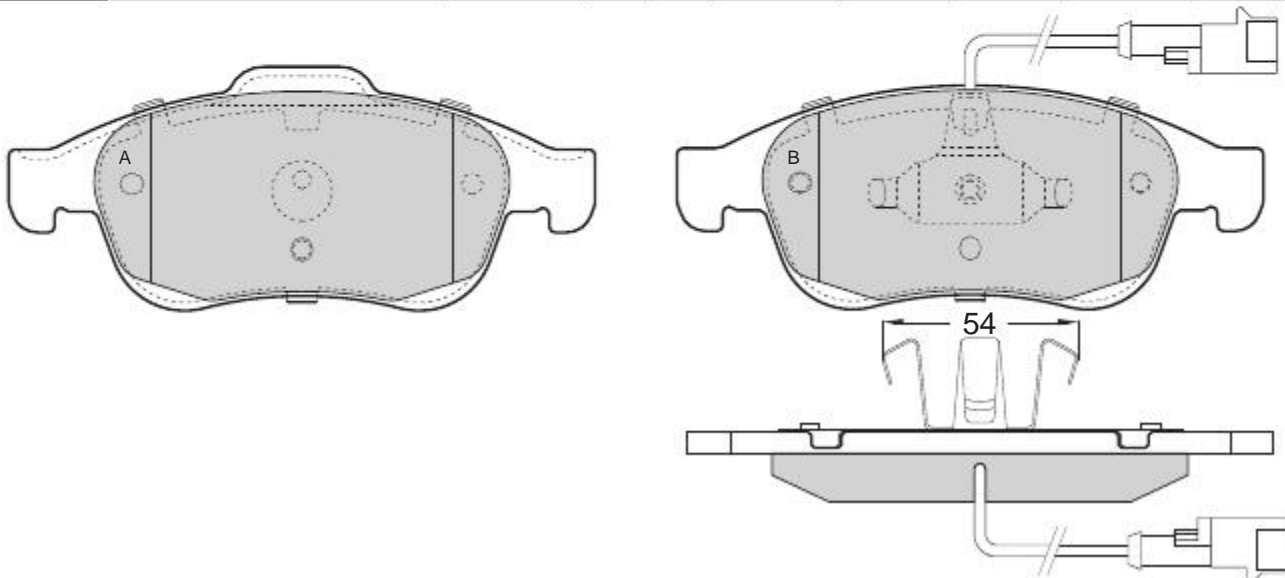

<b>1435</b>	KIA	MANDO	X	117	48,3	15,5	2A 1B-1C		
-------------	-----	-------	---	-----	------	------	-------------	--	--



<b>1436</b>	ALFA ROMEO	ATE	X	155,2	A 64,5 B 59,4	19	2A-2B	2+2	210
-------------	------------	-----	---	-------	------------------	----	-------	-----	-----

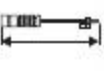

									
<b>1437</b>	ALFA ROMEO	TRW	X	116,6	49,8	17,8	2A-2B	2	210

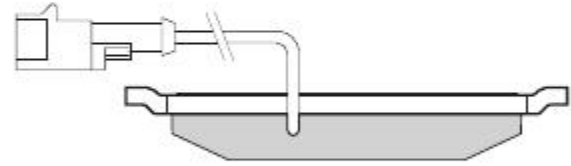
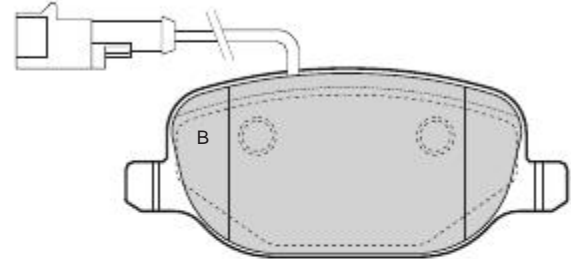
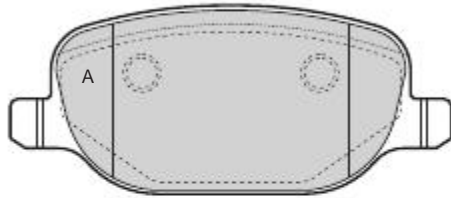



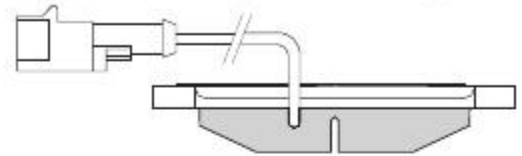
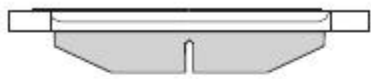
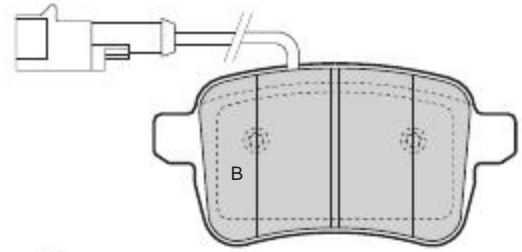
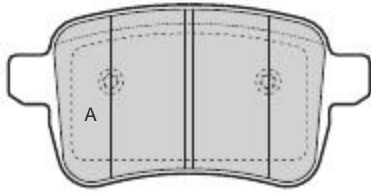



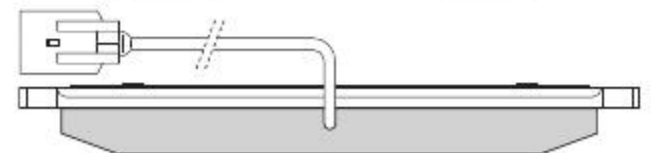
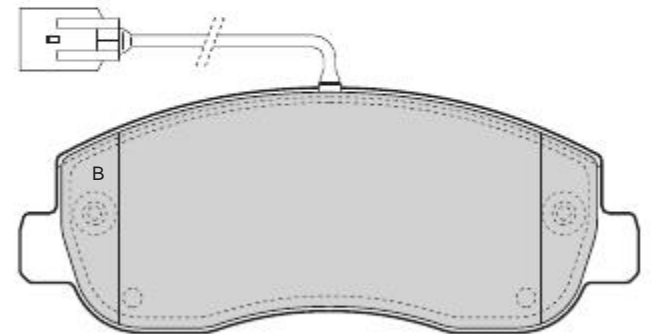
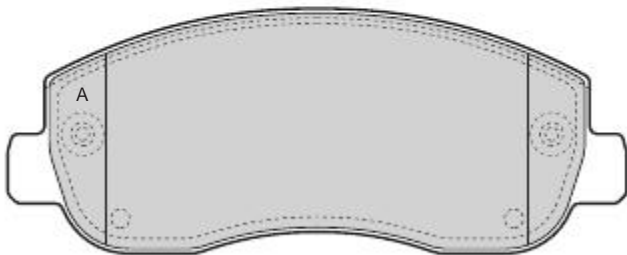

<b>1438</b>	ALFA ROMEO	TRW	X	95,6	48,1	A 17 B 17,8	2A-2B	2	210
-------------	------------	-----	---	------	------	----------------	-------	---	-----



<b>1439</b>	NISSAN - OPEL - RENAULT	BREMBO	X	163,5	64,7	18,2	3A-1B	1	120
-------------	-------------------------	--------	---	-------	------	------	-------	---	-----

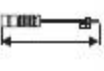

									
<b>1440</b>	OPEL - RENAULT	BREMBO	X	163,5	62,8	18,2	3A-1B	1	305

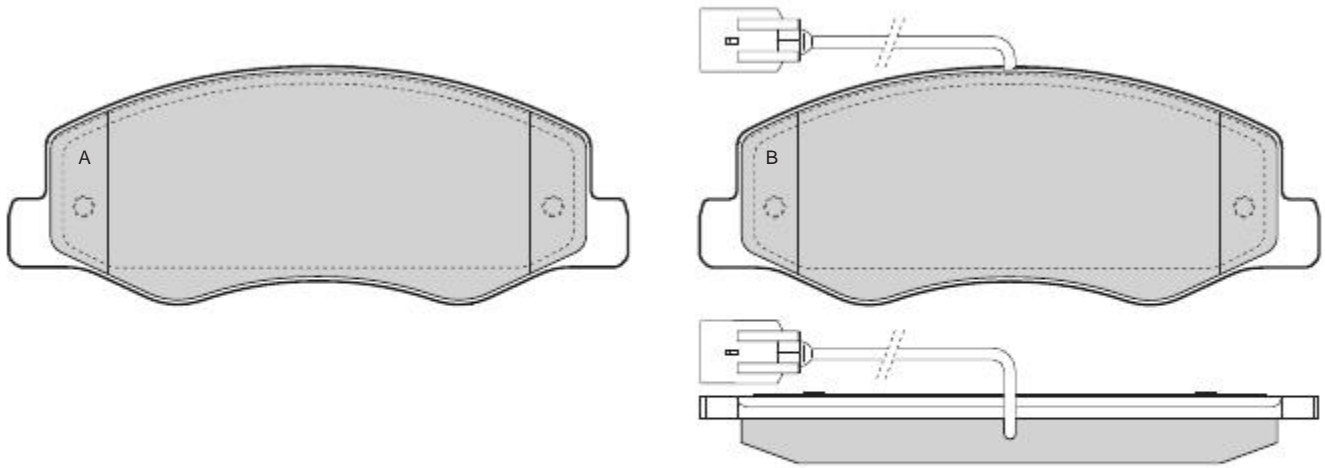



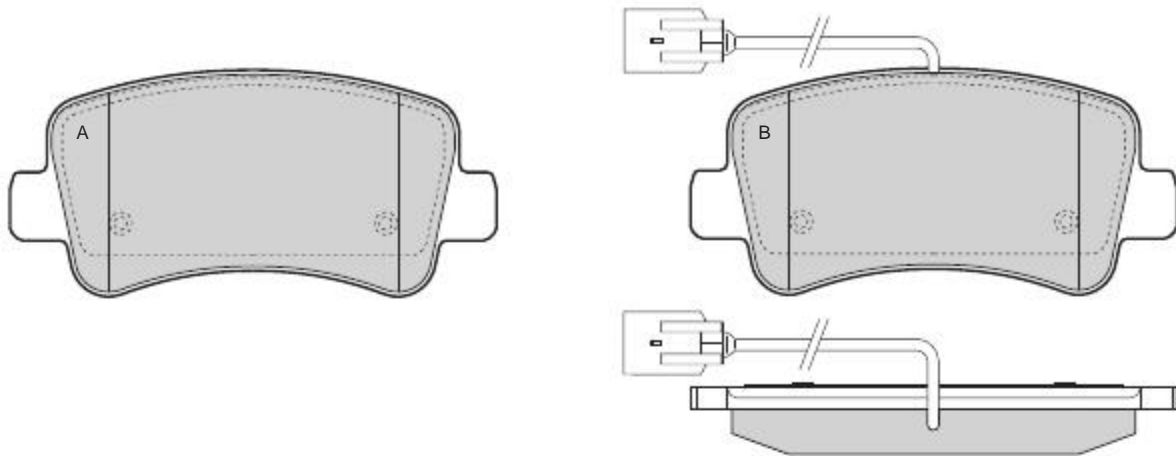



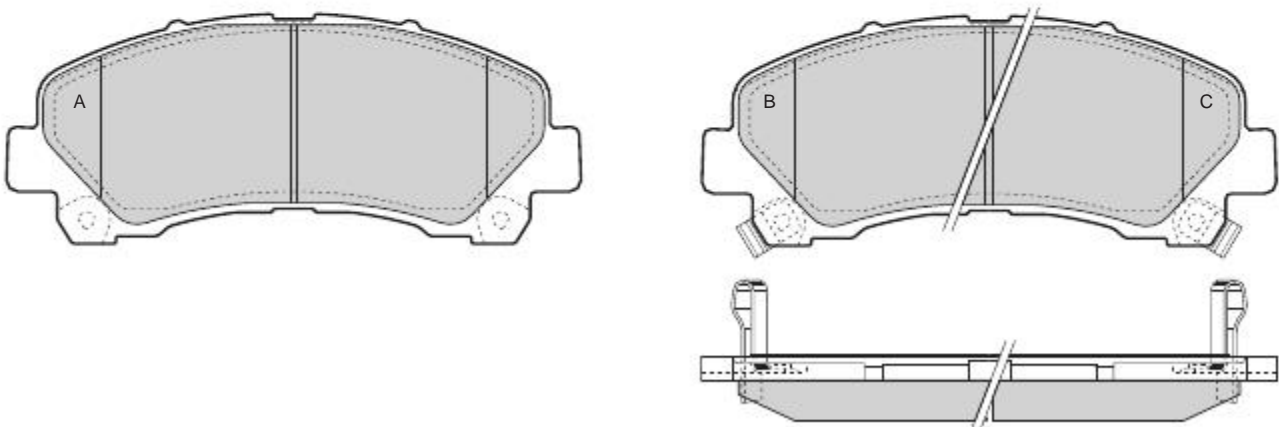



<b>1441</b>	NISSAN - OPEL - RENAULT	BOSCH	X	128,6	59,8	18,2	3A-1B	1	330
-------------	-------------------------	-------	---	-------	------	------	-------	---	-----



<b>1442</b>	ISUZU	AKEBONO	X	151,8	60,8	17,4	2A 1B-1C		
-------------	-------	---------	---	-------	------	------	-------------	--	--



									
1443	ALFA ROMEO	ATE	X	A 156,3 B 155,1	A 71,5 B 68,9	20,3	2A-2B	2	230

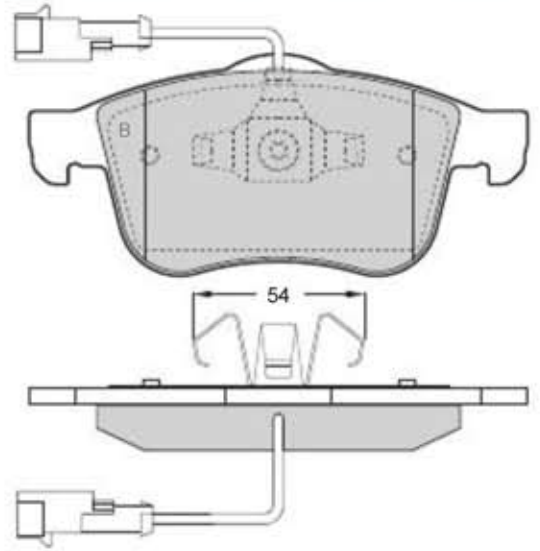



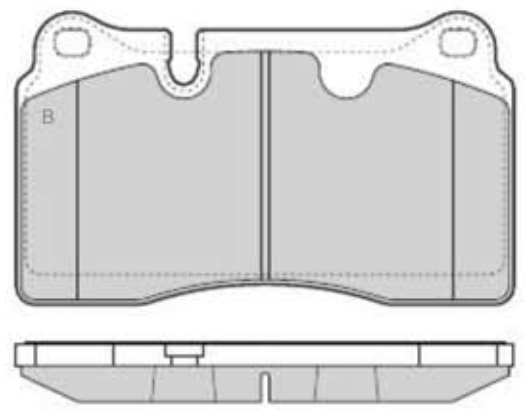
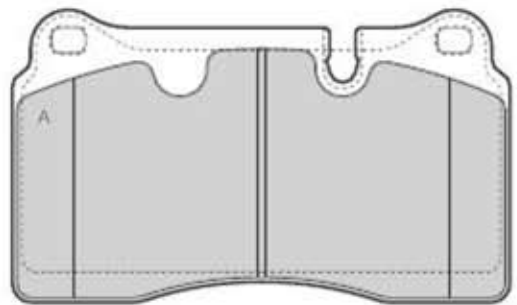



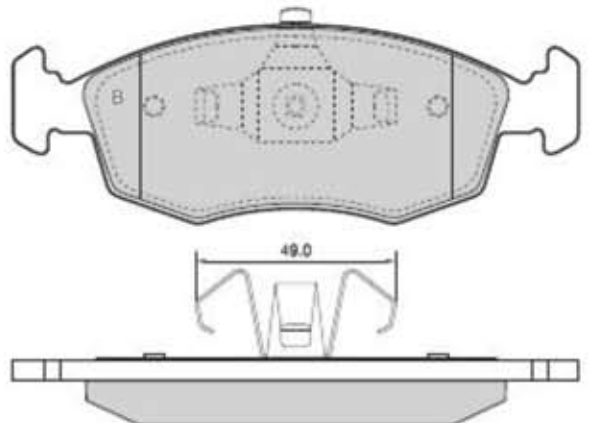
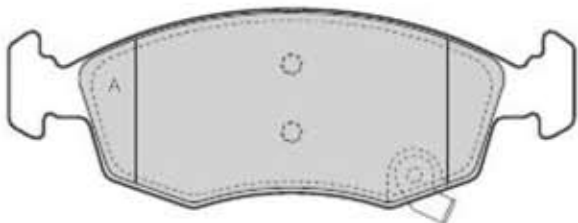



1444	ASTON MARTIN	BREMBO	X	131,7	77,3	15,7	2A-2B		
------	--------------	--------	---	-------	------	------	-------	--	--



1445	LANCIA	ATE	X	149,5	52,5	18	2A-2B		
------	--------	-----	---	-------	------	----	-------	--	--



									
1446	HONDA	AKEBONO	X	136,5	56,4	16,5	2A 1B-1C		

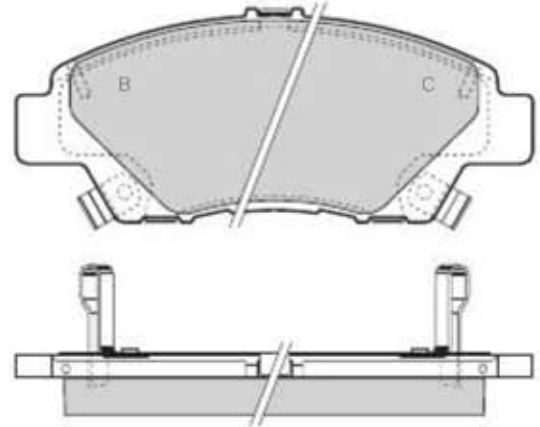



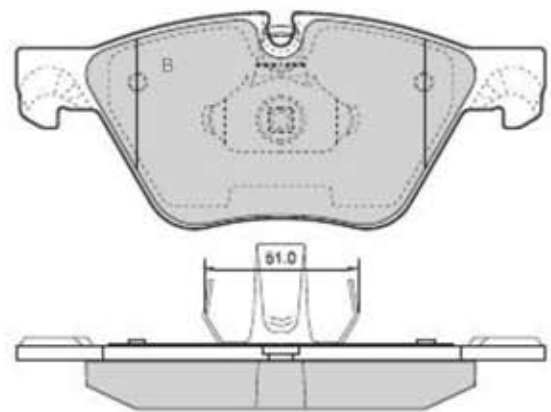
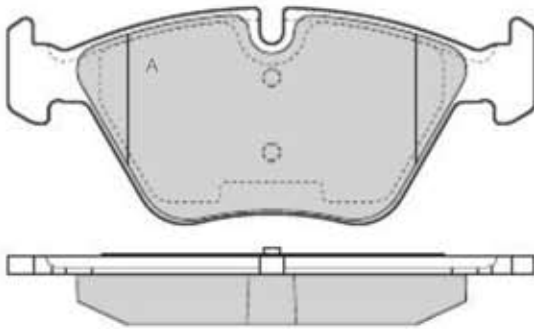



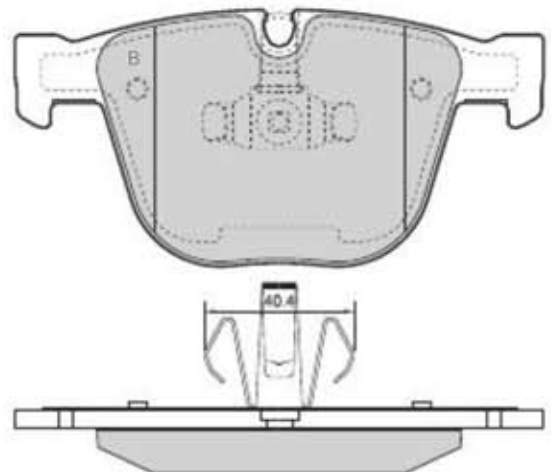
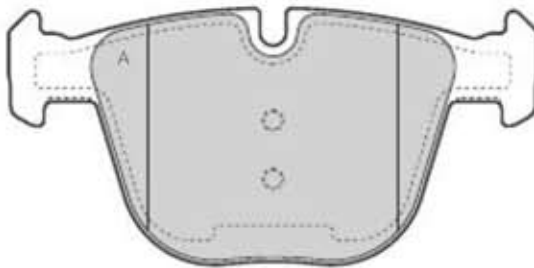

1447	BMW	ATE	X	A 154,8 B 155,2	63,6	A 20,3 B 19,3	2A-2B		
------	-----	-----	---	--------------------	------	------------------	-------	--	--



1448	BMW	ATE	X	139,7	67,9	17,3	2A-2B		
------	-----	-----	---	-------	------	------	-------	--	--

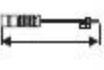

									
<b>1449</b>	BMW	TRW	X	106	A 56 B 63	18	2A-2B		

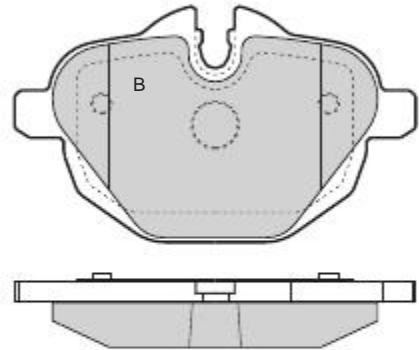
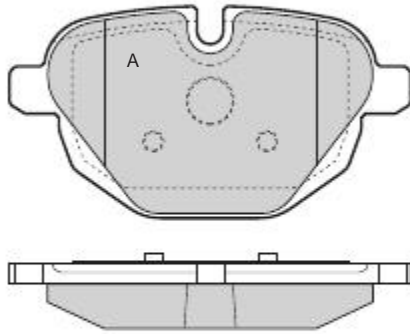



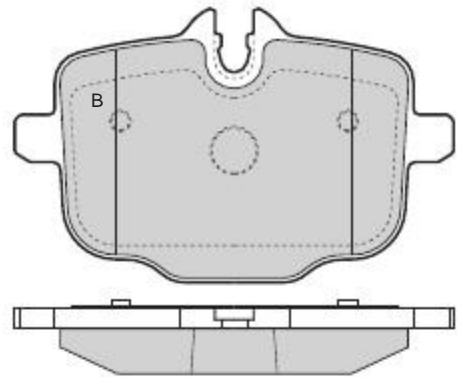
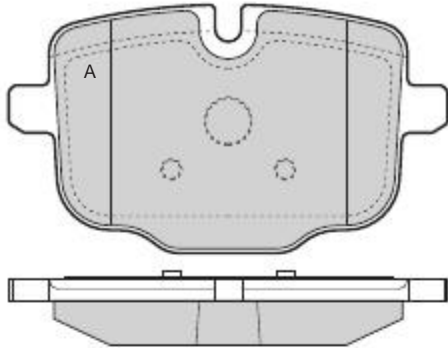



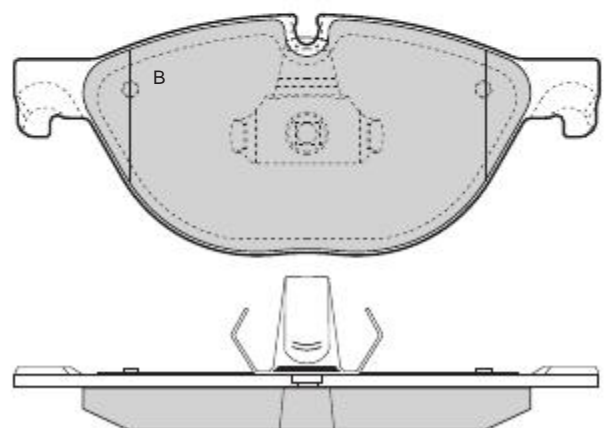
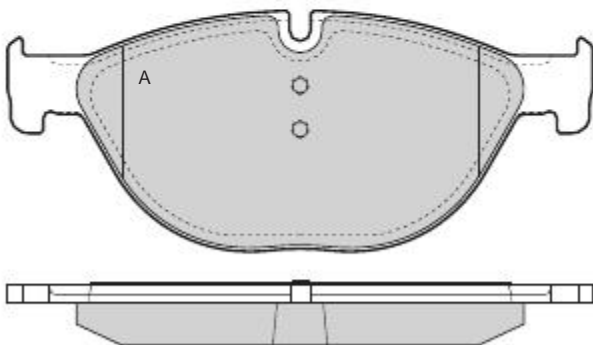



<b>1450</b>	BMW	TRW	X	116	A 65,6 B 73,8	18	2A-2B		
-------------	-----	-----	---	-----	------------------	----	-------	--	--



<b>1451</b>	BMW	ATE	X	A 192,2 B 193	79,3	A 20,2 B 19	2A-2B		
-------------	-----	-----	---	------------------	------	----------------	-------	--	--



									
1452	BMW	ATE	X	A 155,1 B 155,3	68,5	A 18,9 B 20,3	2A-2B		

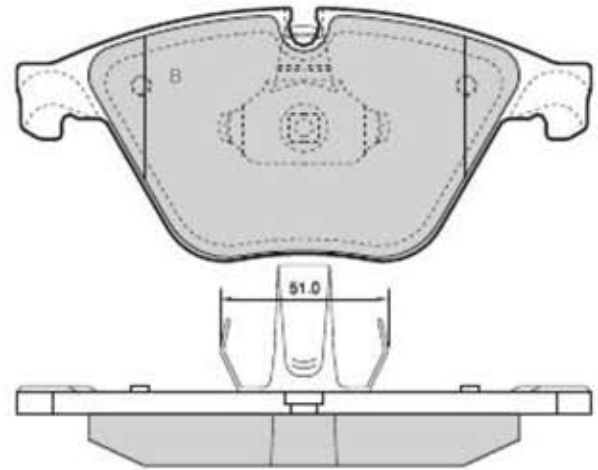
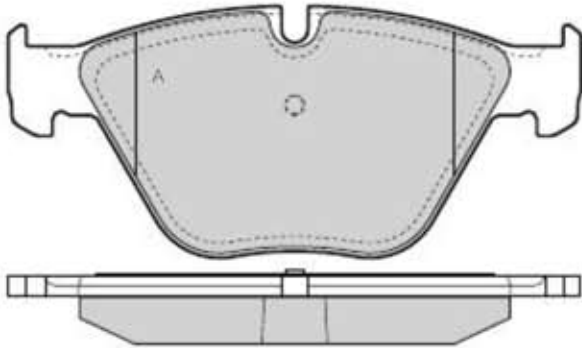



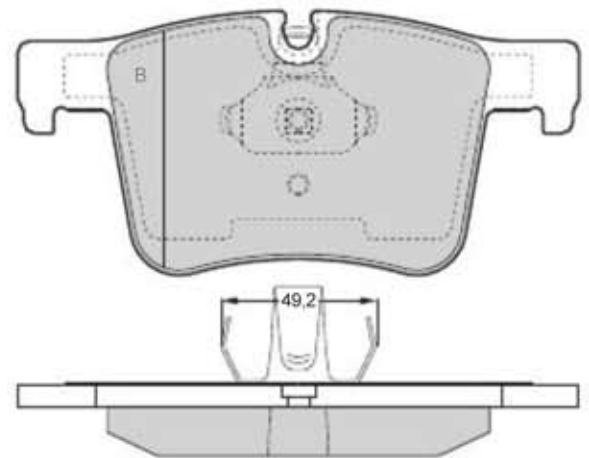
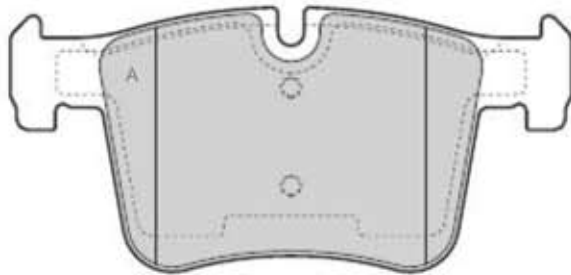



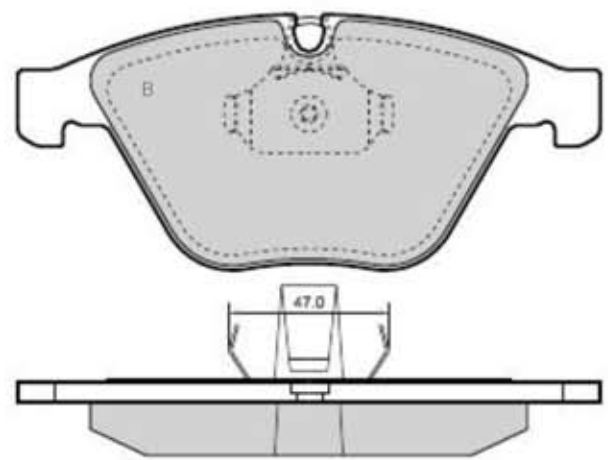
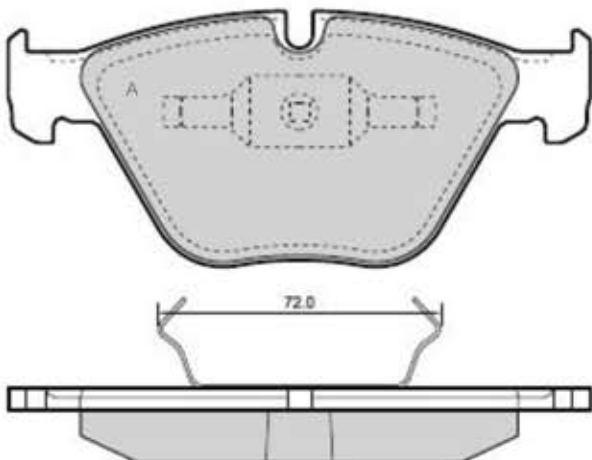



1453	BMW	BOSCH	X	148,3	70	19,2	2A-2B		
------	-----	-------	---	-------	----	------	-------	--	--



1454	BMW	ATE	X	155,1	68,5	20,3	2A-2B		
------	-----	-----	---	-------	------	------	-------	--	--





									
<b>1455</b>	<b>SUZUKI</b>	<b>AKEBONO</b>	<b>X</b>	<b>108,5</b>	<b>45,5</b>	<b>15,5</b>	<b>3A-1B</b>		

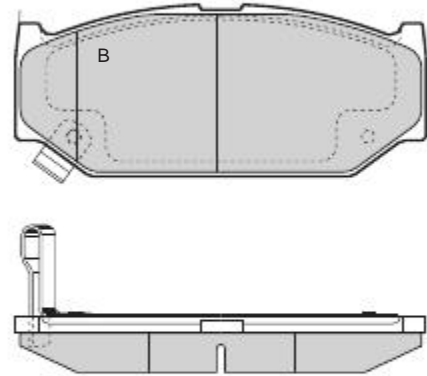
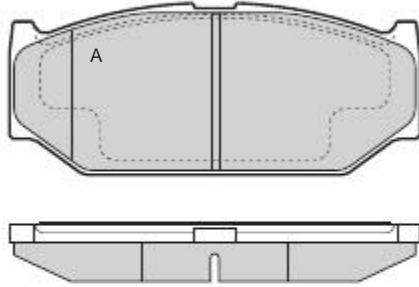



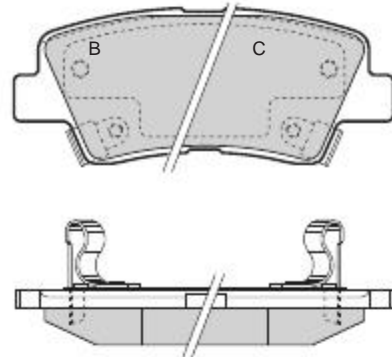
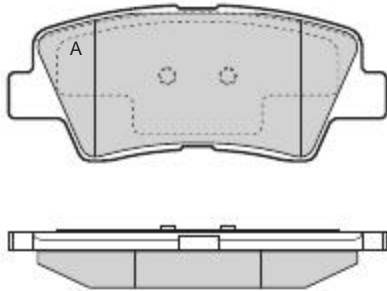



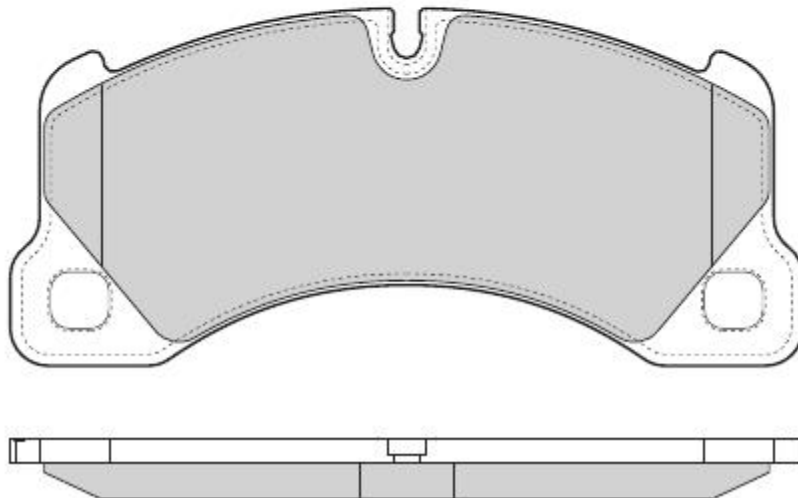



<b>1456</b>	<b>HYUNDAI - KIA</b>						<b>1B-1C</b>		
-------------	----------------------	--	--	--	--	--	--------------	--	--



<b>1457</b>	<b>PORSCHE - VOLKSWAGEN</b>	<b>BREMBO</b>	<b>X</b>	<b>209,5</b>	<b>94,4</b>	<b>16,2</b>	<b>4</b>		
-------------	-----------------------------	---------------	----------	--------------	-------------	-------------	----------	--	--



									
1458	AUDI - PORSCHE VOLKSWAGEN	BREMBO	X	132	77	6.6	4		

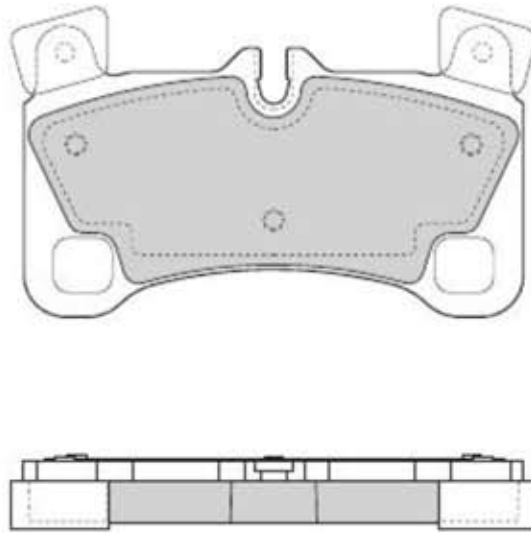



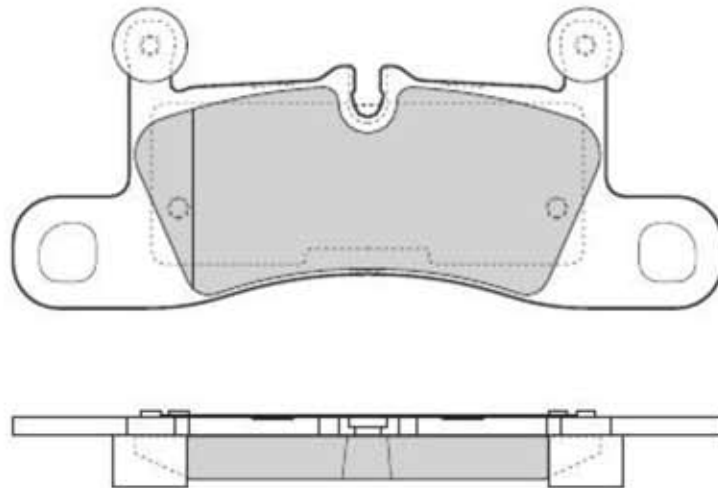



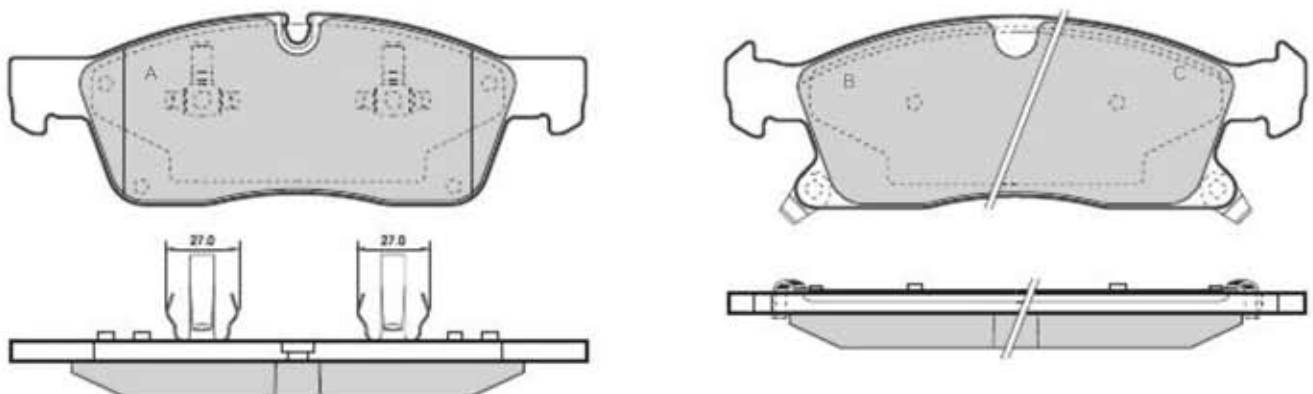



1459	PORSCHE - VOLKSWAGEN	BREMBO	X	187.4	76	17.2	4		
------	----------------------	--------	---	-------	----	------	---	--	--



1460	JEEP	ATE	X	A 193 B-C 194.4	A 64 B-C 64.1	19.2	2A 1B-1C		
------	------	-----	---	--------------------	------------------	------	-------------	--	--



									
1461	JEEP	ATE	X	A 140,2 B-C 141,5	A 50,8 B-C 59,5	18,1	2A 1B-1C		

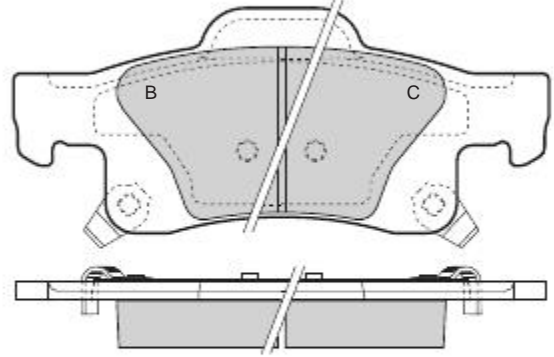
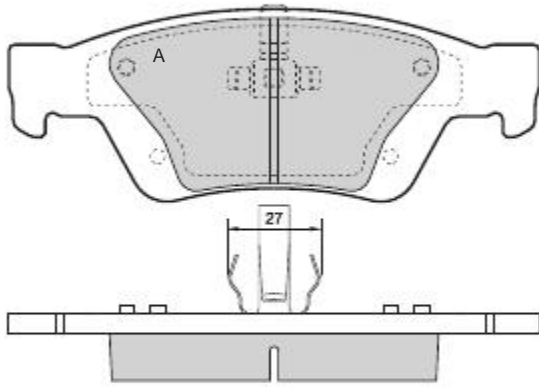



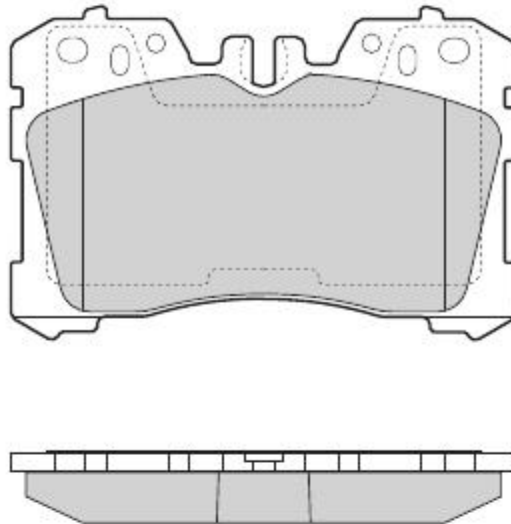



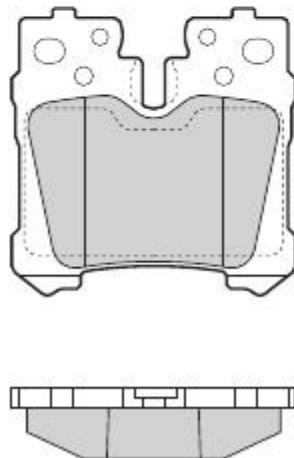



1462	LEXUS	ADV	X	133,6	87,9	19,1	4		
------	-------	-----	---	-------	------	------	---	--	--



1463	LEXUS	ADV	X	75	76,4	19,1	4		
------	-------	-----	---	----	------	------	---	--	--



									
1464	PEUGEOT	ATE	X	155.2	A 60.2 B 55	16.9	2A-2B	1	310

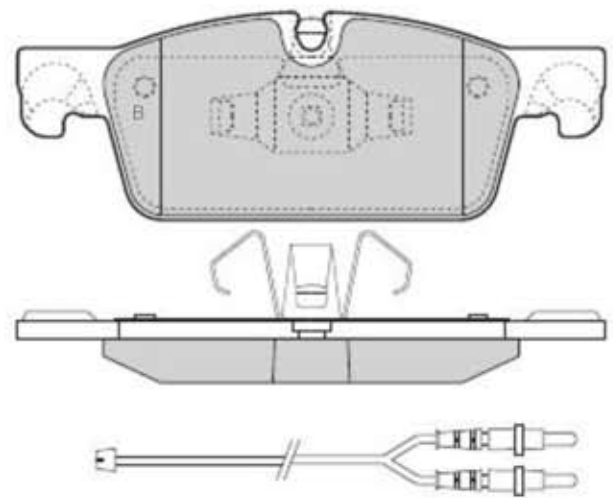
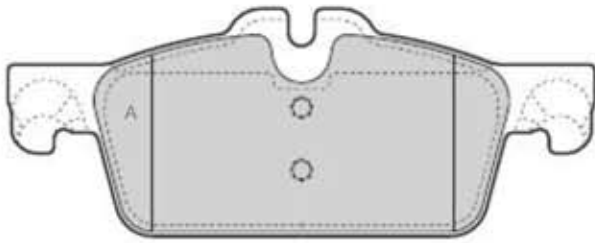



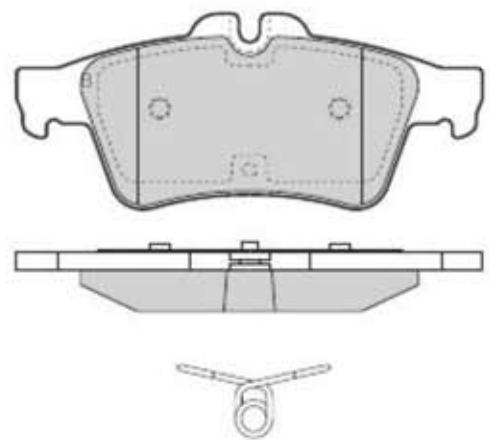
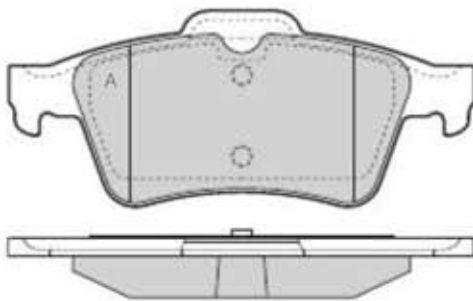



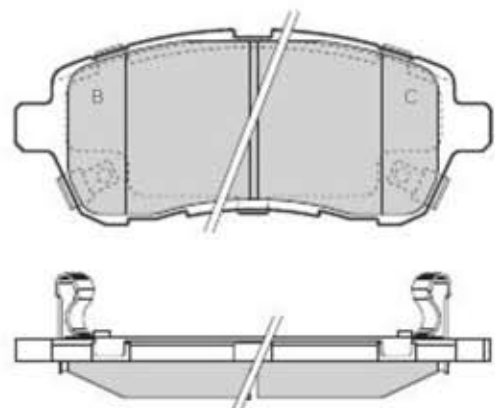
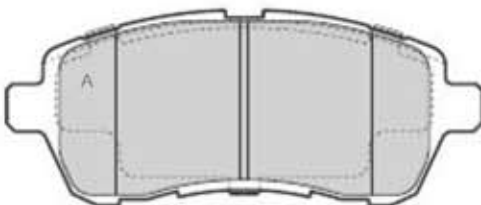

1465	PEUGEOT	ATE	X	123	52	6.4	2A-2B		
------	---------	-----	---	-----	----	-----	-------	--	--



1466	DAIHATSU - MAZDA SUBARU - SUZUKI	GIRLING	X	125.6	51.6	16	2A 1B-1C		
------	-------------------------------------	---------	---	-------	------	----	-------------	--	--

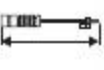

									
<b>1467</b>	SUZUKI	AKEBONO	X	98,6	40,2	15,1	2A 1B-1C		

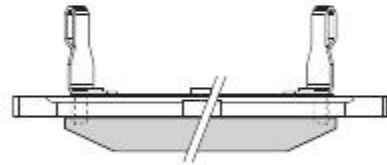
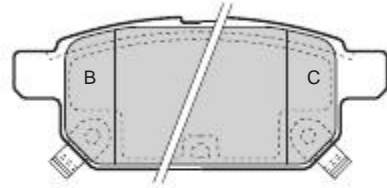
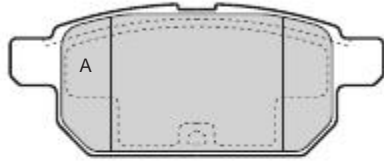



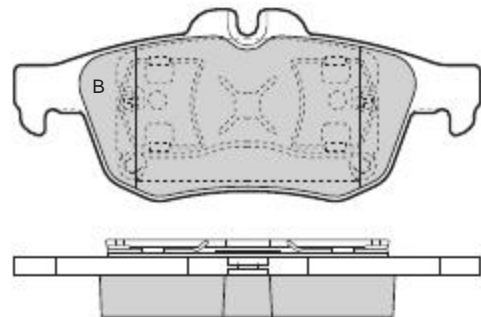
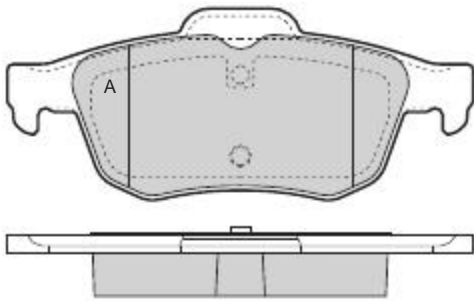



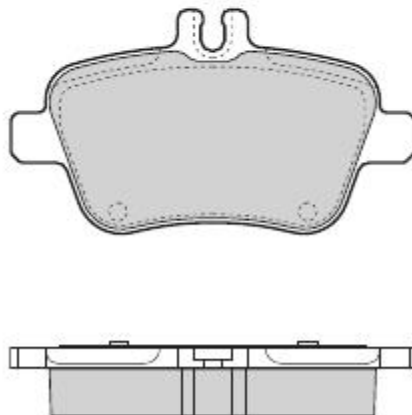

<b>1468</b>	RENAULT	ATE	X	123,1	50,6	16,9	2A-2B		
-------------	---------	-----	---	-------	------	------	-------	--	--



<b>1469</b>	MERCEDES	TRW	X	106,6	59,1	18,5	4		
-------------	----------	-----	---	-------	------	------	---	--	--

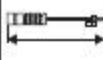

									
<b>1470</b>	KIA	TRW	X	133	58,2	17,8	2A 1B-1C		

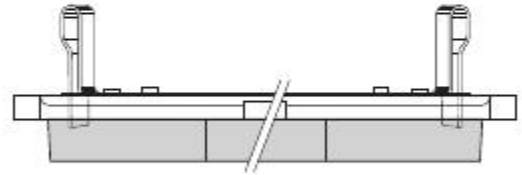
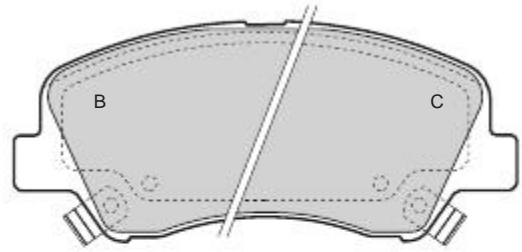
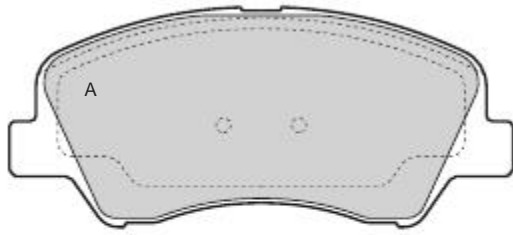



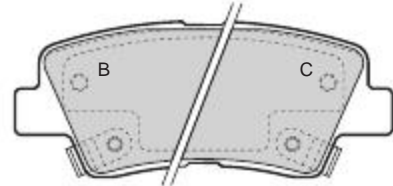
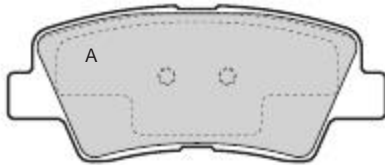



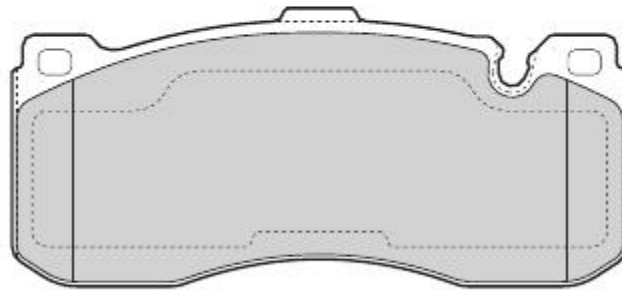

<b>1471</b>	KIA - HYUNDAI	AKEBONO	X	99,8	41,2	15,6	2A 1B-1C		
-------------	---------------	---------	---	------	------	------	-------------	--	--



<b>1472</b>	BMW	BREMBO	X	164,7	73,5	16,9	4		
-------------	-----	--------	---	-------	------	------	---	--	--

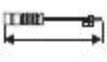

									
1473	BMW	BREMBO	X	85,4	76,1	16,2	4		

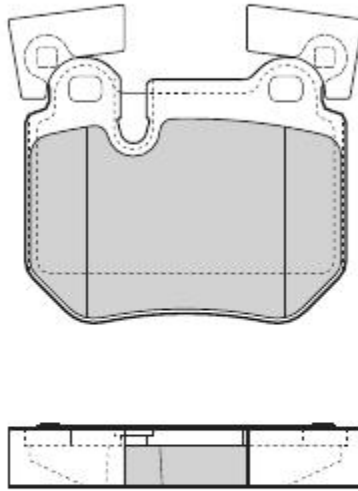



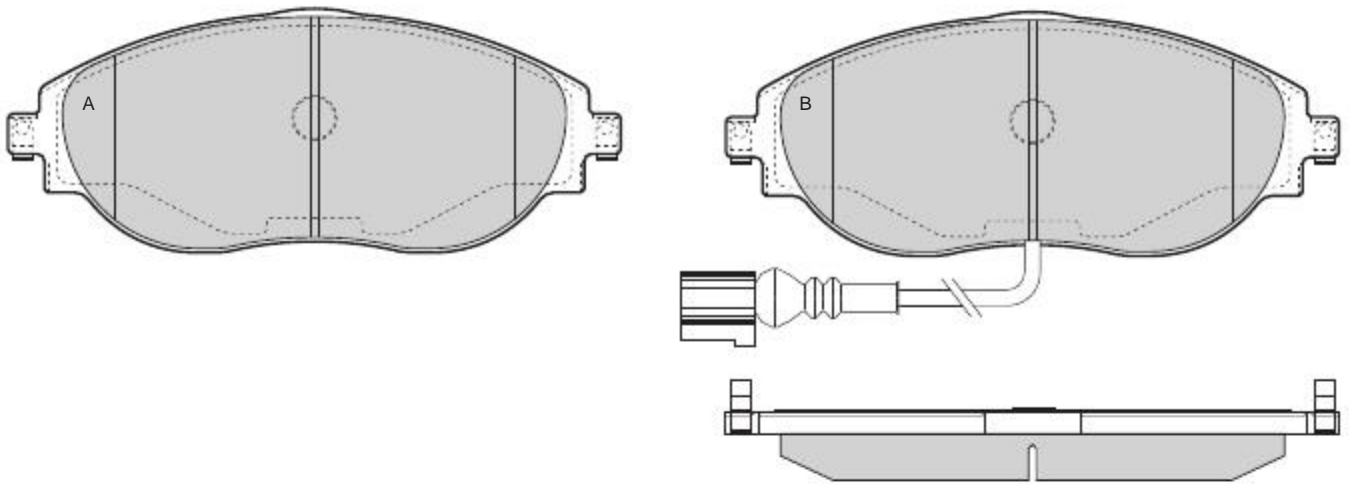



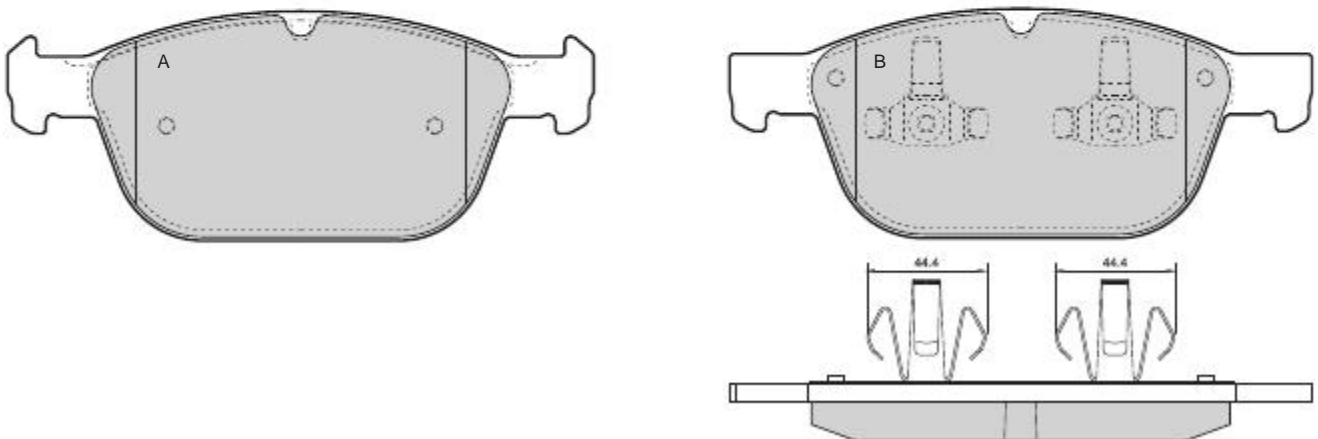



1474	SEAT - VOLKSWAGEN	TRW	X	175,2	69,7	20	3A-1B	1	200
------	-------------------	-----	---	-------	------	----	-------	---	-----



1475	VOLVO	ATE	X	A 194,3 B 193,1	76	19,7	2A-2B		
------	-------	-----	---	--------------------	----	------	-------	--	--



									
1476	AUDI	ATE	X	193,2	A 73,8 B 70,8	20	2A-2B	2	300

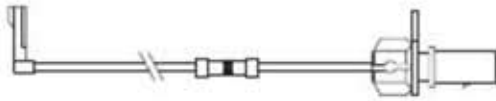
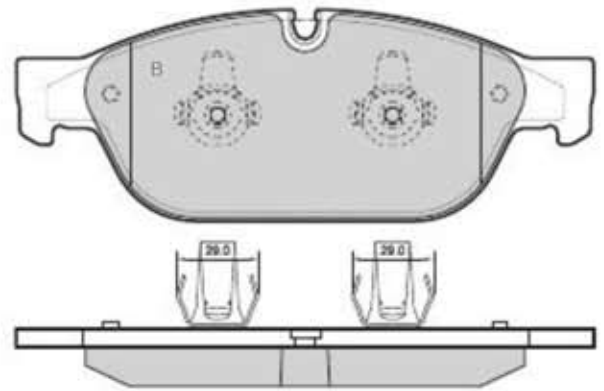
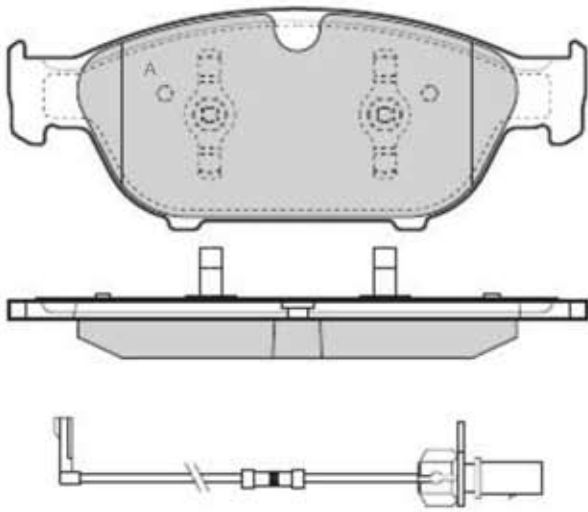



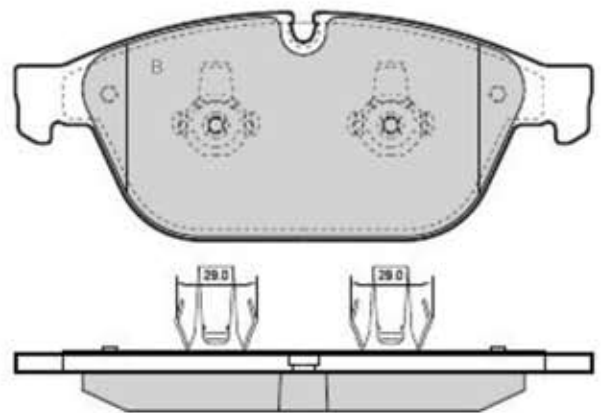
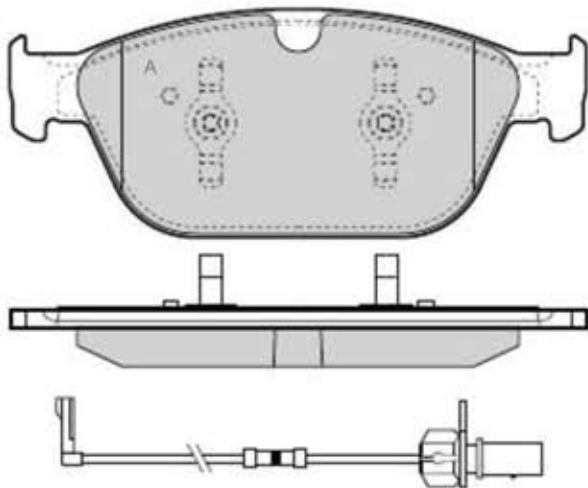



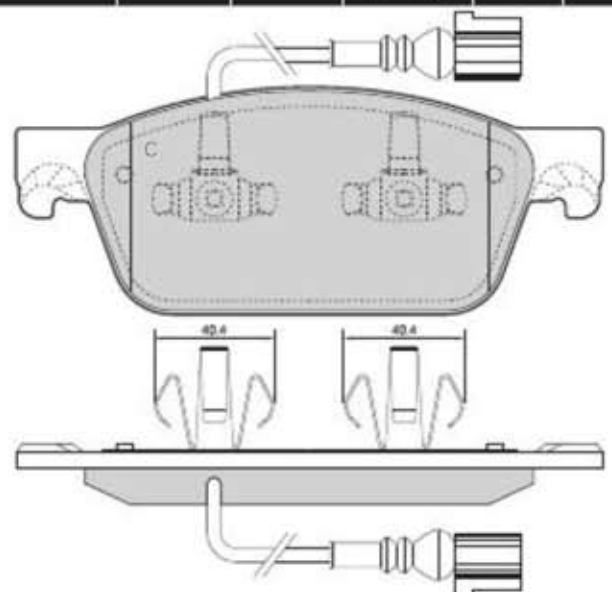
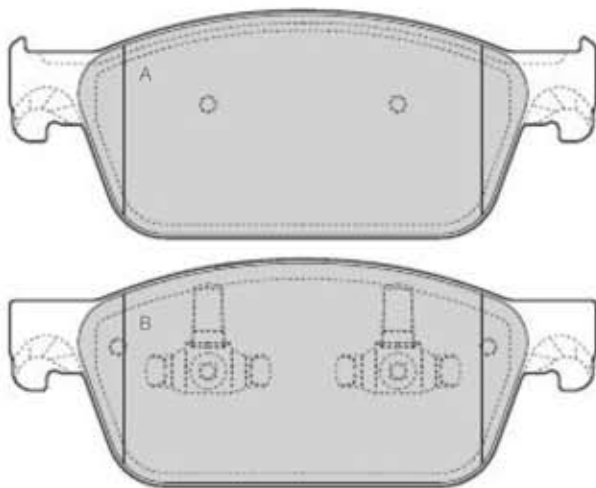

1477	AUDI	ATE	X	193	76,4	20	2A-2B	2	800
------	------	-----	---	-----	------	----	-------	---	-----



1478	VOLKSWAGEN	ATE	X	193	75	18,2	2A 1B-1C	1	200
------	------------	-----	---	-----	----	------	-------------	---	-----



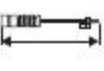

									
<b>1479</b>	<b>BMW</b>	<b>ATE</b>	<b>X</b>	<b>A 154,8 B 155,2</b>	<b>63,6</b>	<b>20,3</b>	<b>2A-2B</b>		

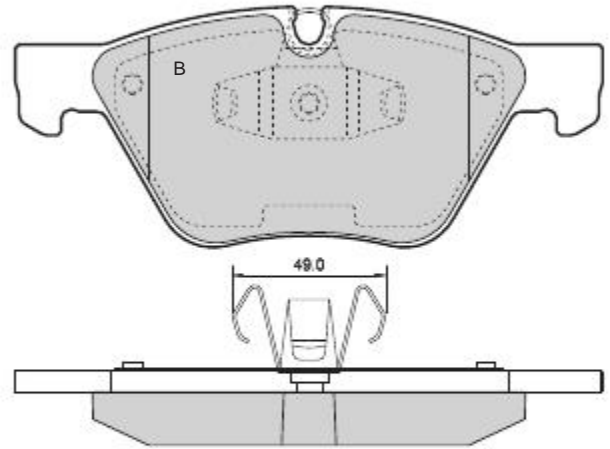
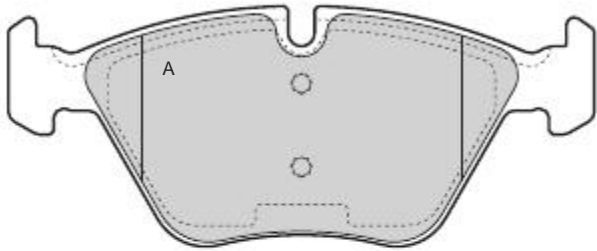



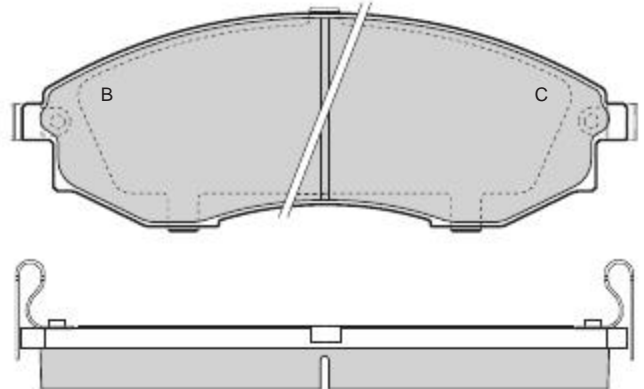
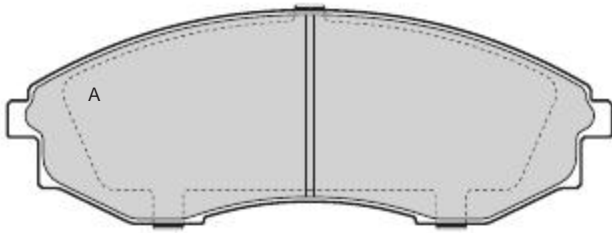



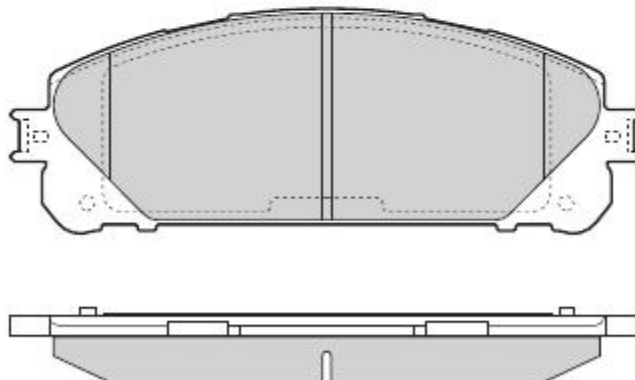



<b>1480</b>	<b>SSANGYONG</b>	<b>SUMITOMO</b>	<b>X</b>	<b>159,8</b>	<b>56,4</b>	<b>16,5</b>	<b>2A 1B-1C</b>		
-------------	------------------	-----------------	----------	--------------	-------------	-------------	---------------------	--	--



<b>1481</b>	<b>LEXUS - TOYOTA</b>	<b>ADVICS</b>	<b>X</b>	<b>167</b>	<b>59,4</b>	<b>18,2</b>	<b>4</b>		
-------------	-----------------------	---------------	----------	------------	-------------	-------------	----------	--	--



									
1482	LEXUS - TOYOTA	AKEBONO	X	115,2	45,7	15,8	4		

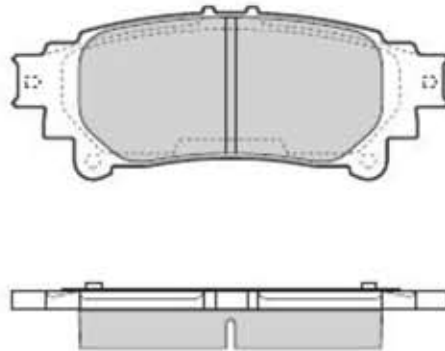



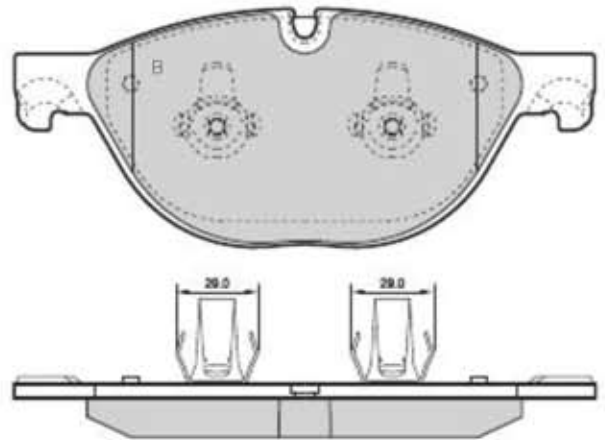
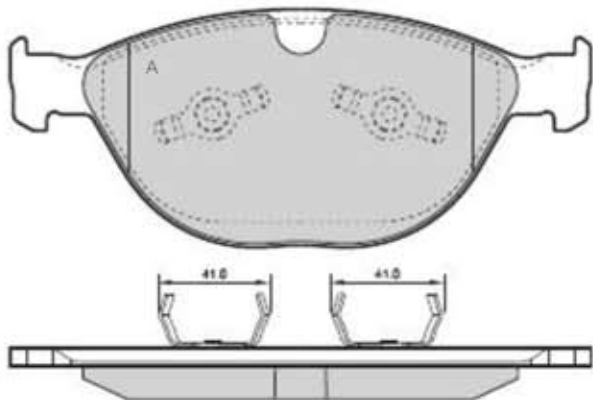



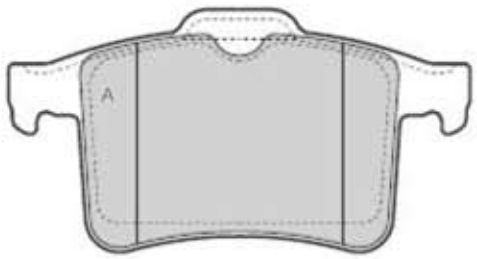



1483	JAGUAR	ATE	X	A 193,2 B 193	A 79,2 B 79,3	A 17,9 B 18,7	2A-2B		
------	--------	-----	---	------------------	------------------	------------------	-------	--	--



1484	JAGUAR		X	122	64,2	16,2	2A-2B		
------	--------	--	---	-----	------	------	-------	--	--



									
<b>1485</b>	LEXUS - TOYOTA	AKEBONO	X	98,6	42,5	15	2A-2B		

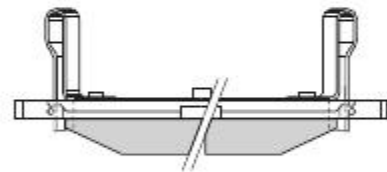
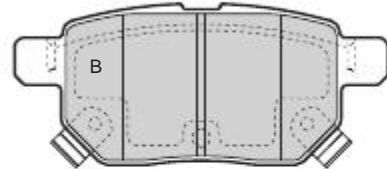
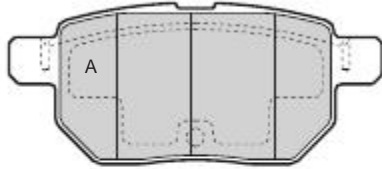



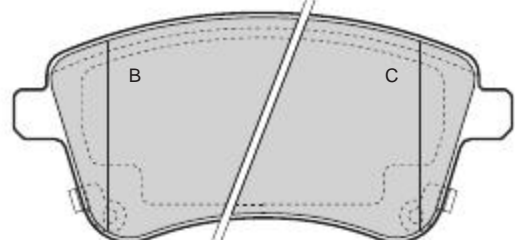
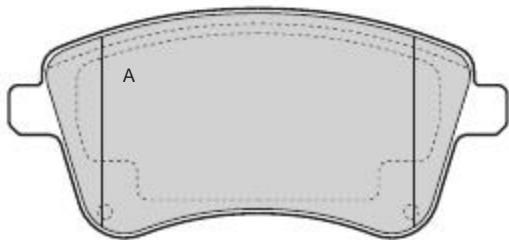



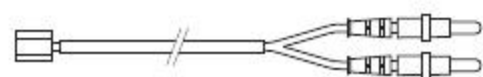
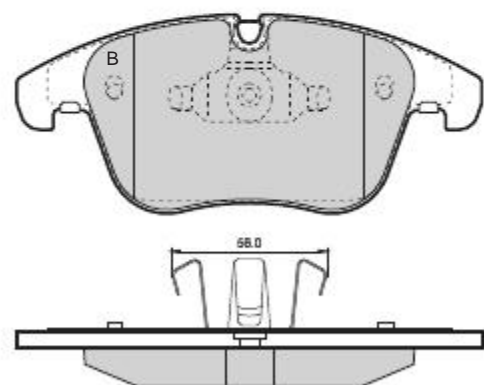
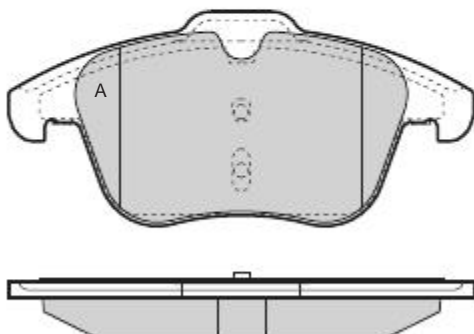

<b>1486</b>	HYUNDAI - KIA	TRW	X	131,6	60,6	19,5	2A 1B-1C		
-------------	---------------	-----	---	-------	------	------	-------------	--	--



<b>1487</b>	CITROEN	ATE	X	155,2	A 71,6 B 66,7	19,3	2A-2B	2	310
-------------	---------	-----	---	-------	------------------	------	-------	---	-----

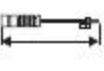

									
1488	BMW	ATE	X	A 154,8 B 155,2	63,6	20,3	2A-2B		

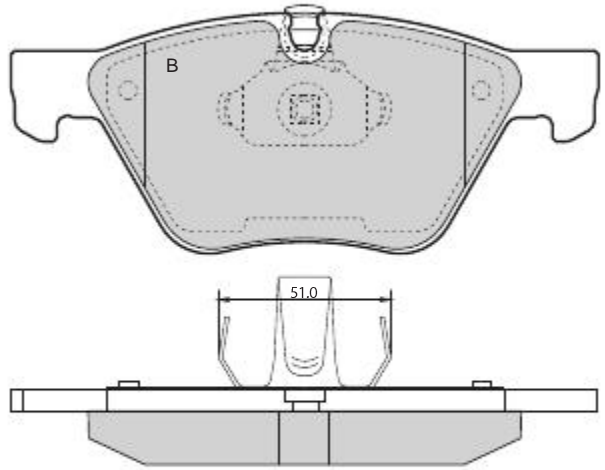
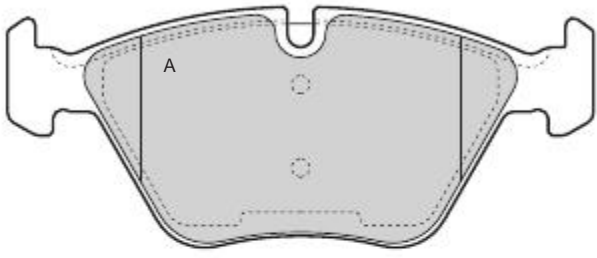



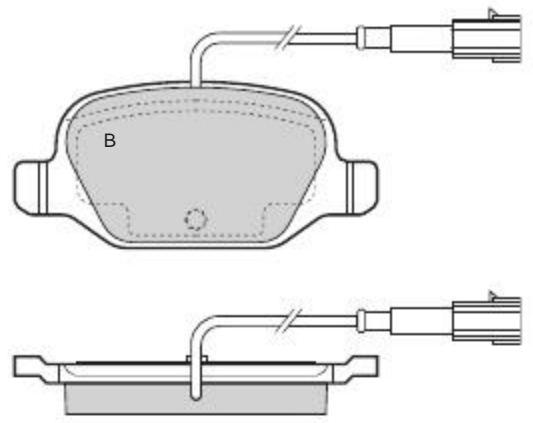
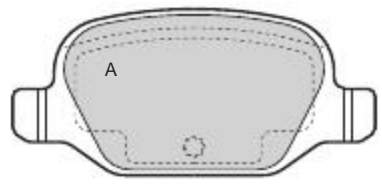



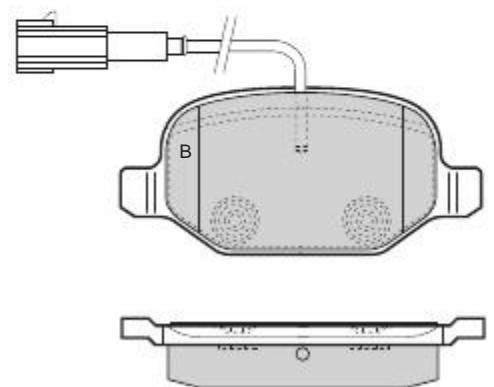
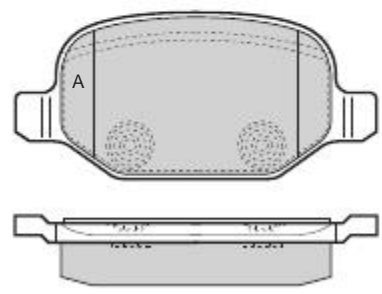

1489	FIAT	TRW	X	95,8	43,9	13,9	2A-2B	2	400
------	------	-----	---	------	------	------	-------	---	-----



1490	ALFA ROMEO	TRW	X	95,8	43,9	17,3	2A-2B	2	190
------	------------	-----	---	------	------	------	-------	---	-----

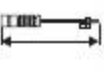

									
<b>1491</b>	<b>CITROEN</b>	<b>TRW</b>	<b>X</b>	<b>129</b>	<b>A 53 B 61,2</b>	<b>18,5</b>	<b>2A-2B</b>		

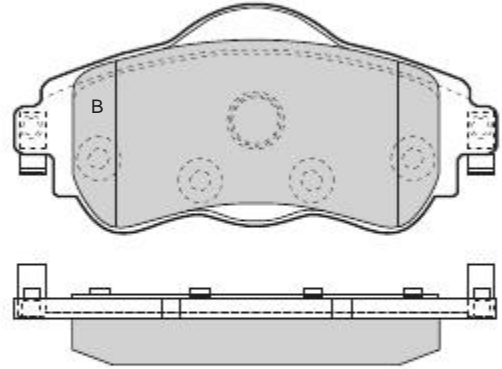
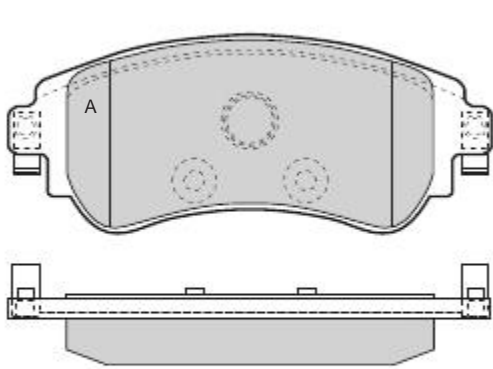



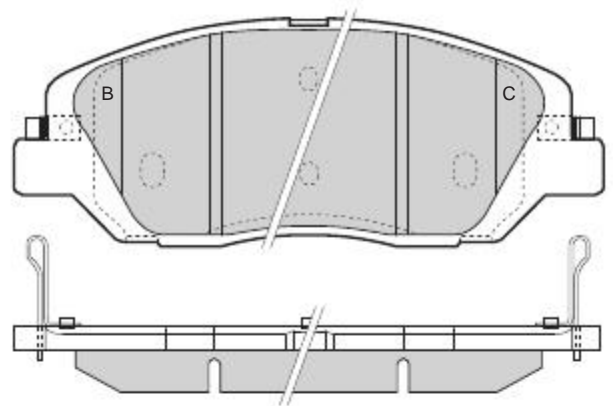
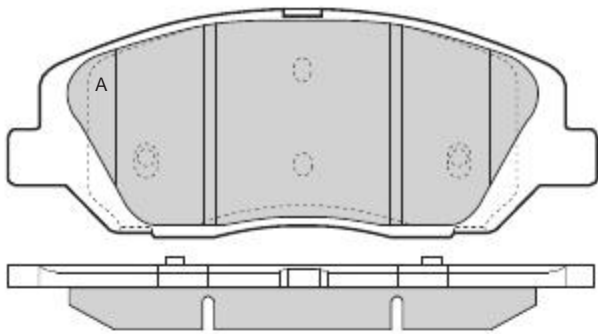



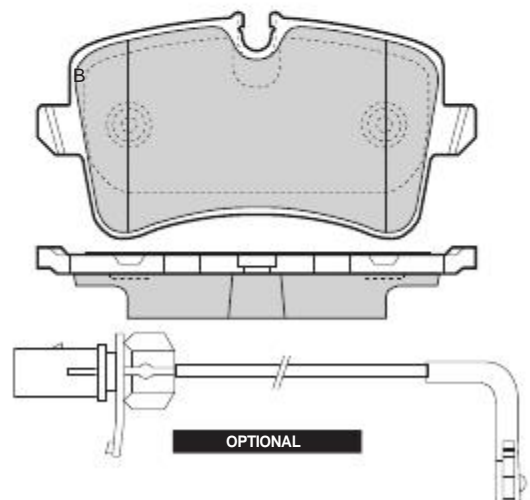
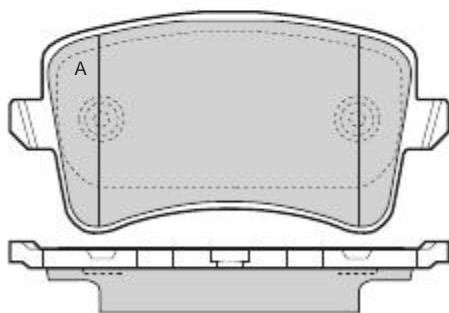



<b>1492</b>	<b>SSANGYONG</b>	<b>MANDO</b>	<b>X</b>	<b>156,8</b>	<b>60,67</b>	<b>17</b>	<b>2A 1B-1C</b>		
-------------	------------------	--------------	----------	--------------	--------------	-----------	---------------------	--	--



<b>1493</b>	<b>AUDI</b>	<b>TRW</b>	<b>X</b>	<b>116,5</b>	<b>A 58,3 B 59,6</b>	<b>17,4</b>	<b>2A-2B</b>	<b>1</b>	<b>215</b>
-------------	-------------	------------	----------	--------------	--------------------------	-------------	--------------	----------	------------



									
<b>1494</b>	<b>BMW</b>	<b>BOSCH</b>	<b>X</b>	<b>123,1</b>	<b>A 45,2 B 46,6</b>	<b>17,5</b>	<b>2A-2B</b>		

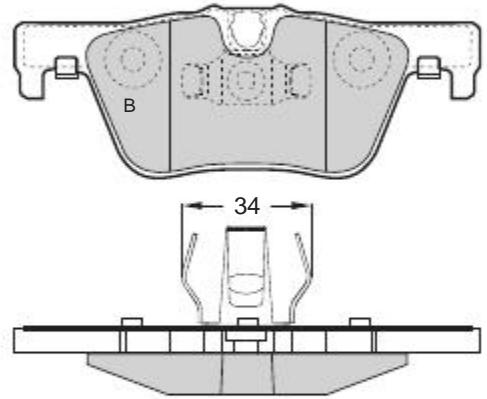
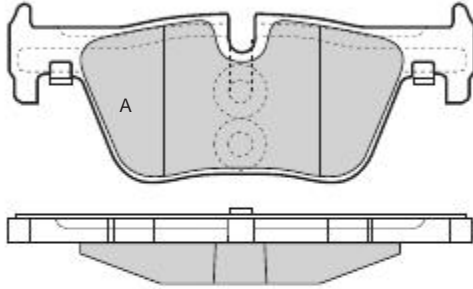



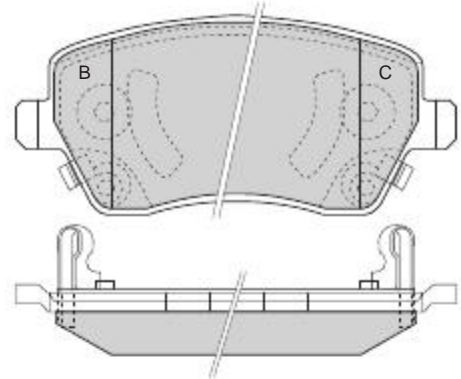
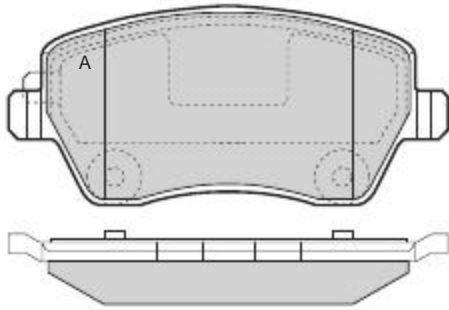



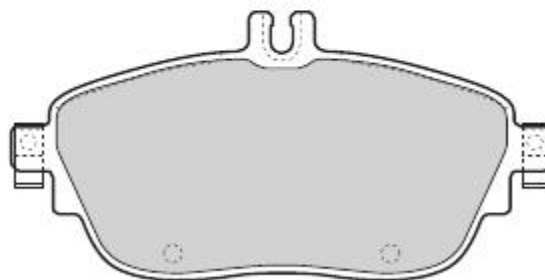

<b>1495</b>	<b>NISSAN</b>	<b>TRW</b>	<b>X</b>	<b>116,4</b>	<b>A 52,3 B-C 52,4</b>	<b>17,3</b>	<b>2A 1B-1C</b>		
-------------	---------------	------------	----------	--------------	----------------------------	-------------	---------------------	--	--



<b>1496</b>	<b>MERCEDES</b>	<b>TRW</b>	<b>X</b>	<b>144</b>	<b>71,5</b>	<b>19</b>	<b>4</b>		
-------------	-----------------	------------	----------	------------	-------------	-----------	----------	--	--

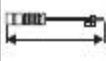

									
<b>1497</b>	MERCEDES	TRW	X	129	71,3	19,2	4		

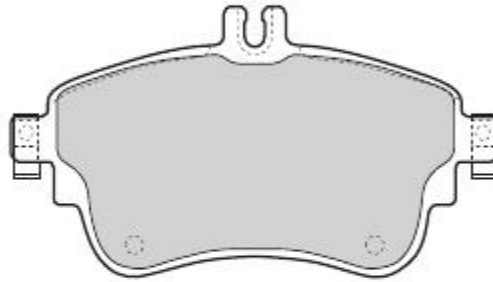



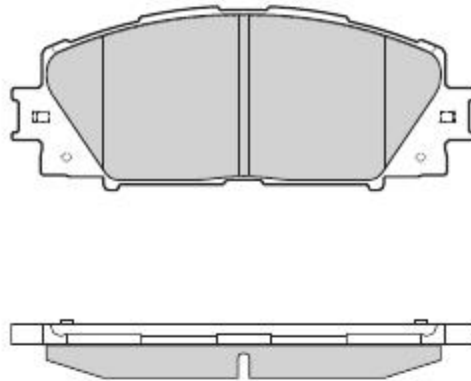



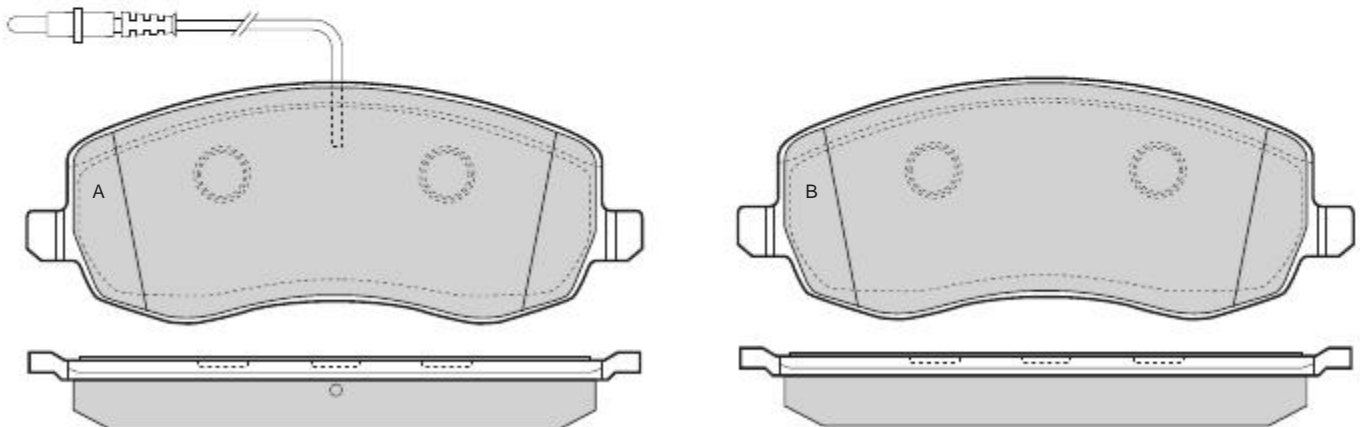



<b>1498</b>	LEXUS - TOYOTA	AKEBONO	X	122,7	49,61	15,6	4		
-------------	----------------	---------	---	-------	-------	------	---	--	--



<b>1499</b>	CITROEN - FIAT - LANCIA PEUGEOT	TRW	X	162,7	63,79	19,5	2A-2B	2	348
-------------	------------------------------------	-----	---	-------	-------	------	-------	---	-----



									
1500	BMW	ATE	X	A 154,1 B 154,2	A 68,5 B 68,4	A 19 B 20	2A-2B		

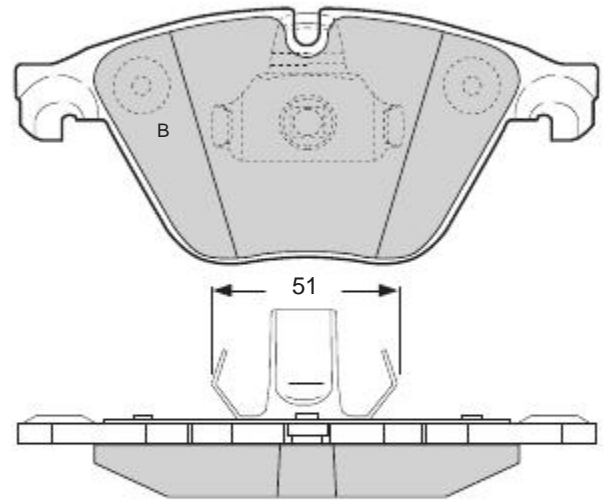
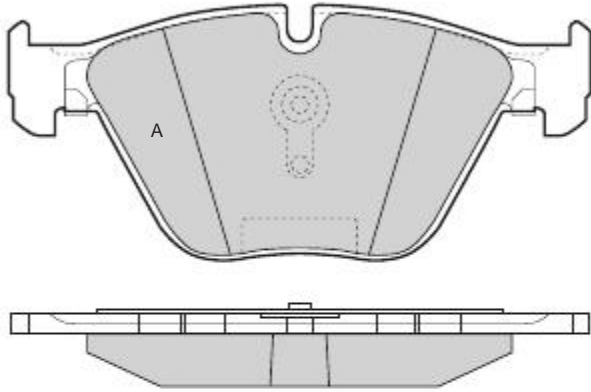



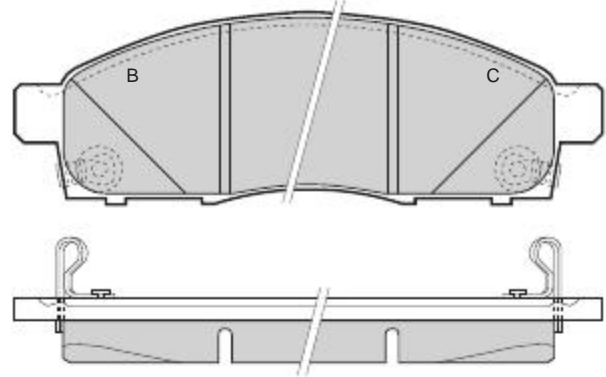
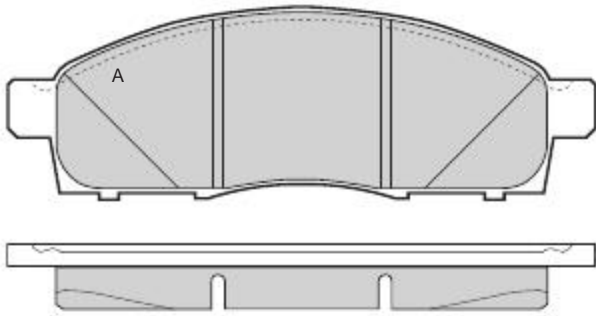



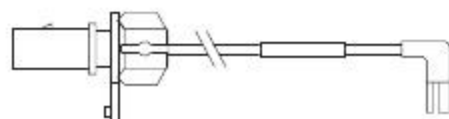
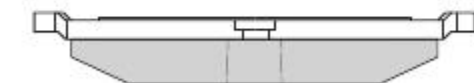
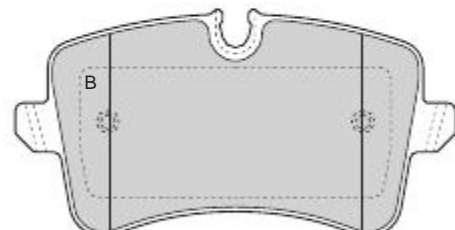
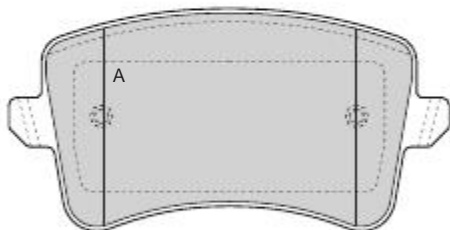



1501	NISSAN	TOKICO	X	155,4	50,5	17	2A 1B-1C		
------	--------	--------	---	-------	------	----	-------------	--	--



1502	AUDI	TRW	X	116,4	A 58,8 B 60	17,4	2A-2B	1	215
------	------	-----	---	-------	----------------	------	-------	---	-----





									
1503	BMW	ATE	X	A 155,8 B 156,8	61,7	18,2	2A-2B		

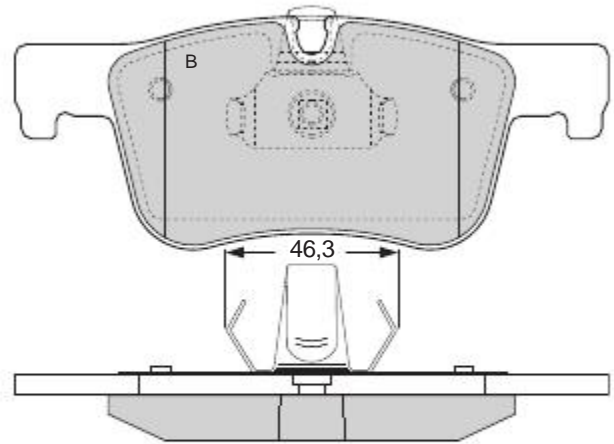
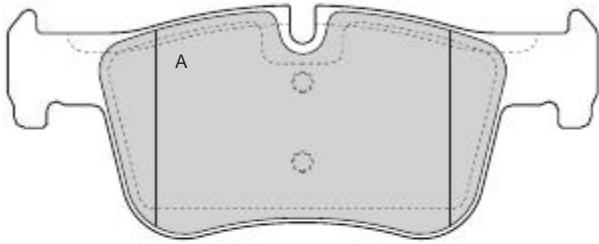



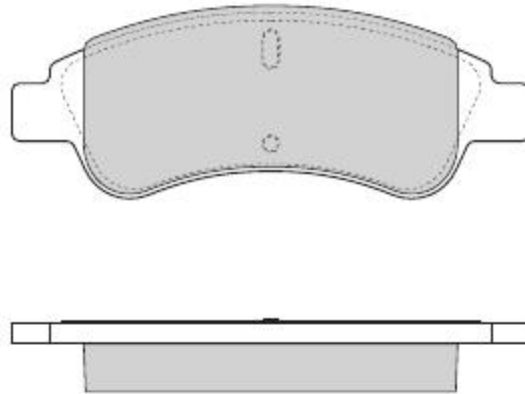



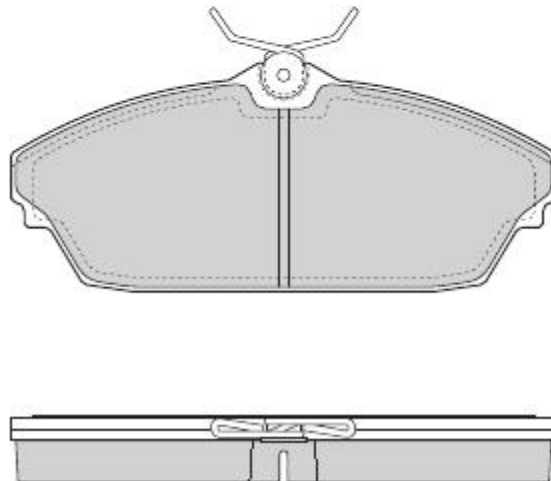



1504	CITROEN	BOSCH	X	136,8	51,6	19	4		
------	---------	-------	---	-------	------	----	---	--	--



1505	TATA	GIRLING	X	144	60,5	17,7	4		
------	------	---------	---	-----	------	------	---	--	--



									
1506	VOLKSWAGEN	ATE	X	156,4	78,7	19,6	2A-2B	2	210

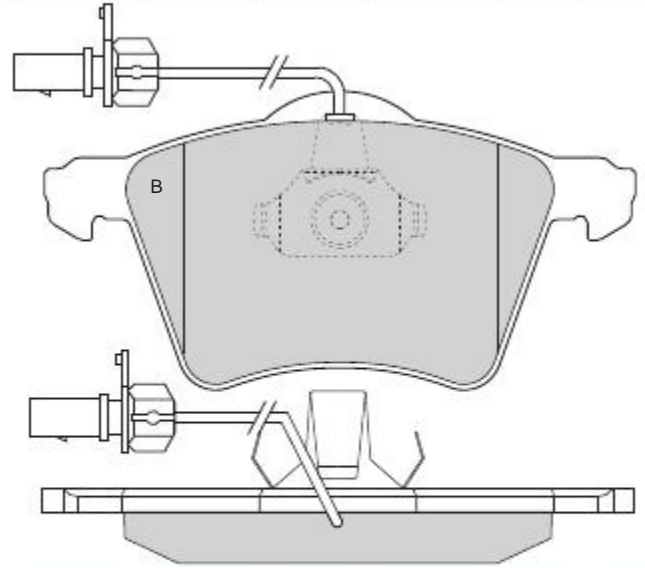
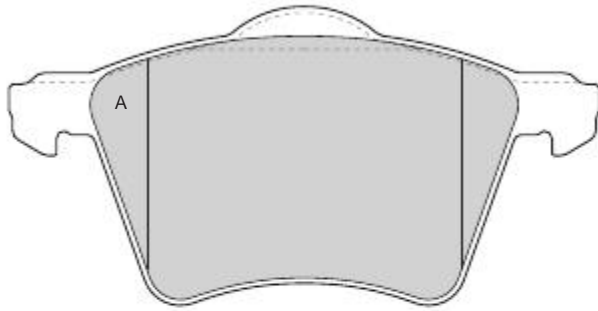



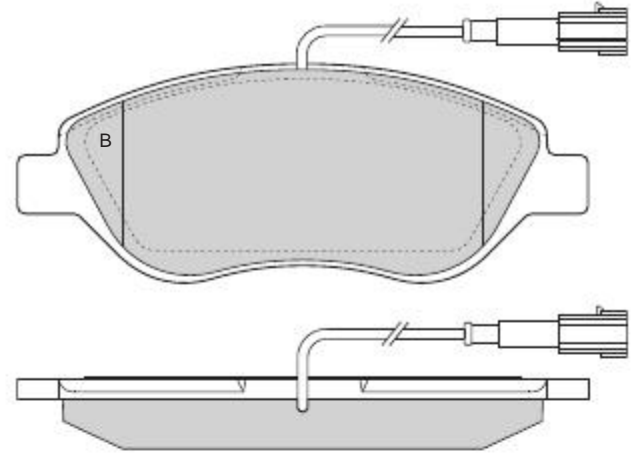
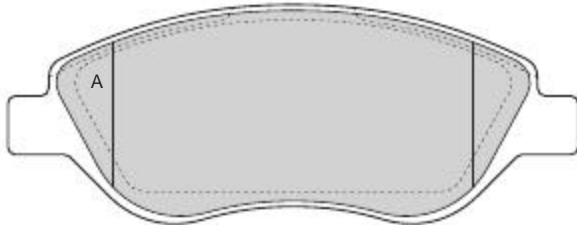



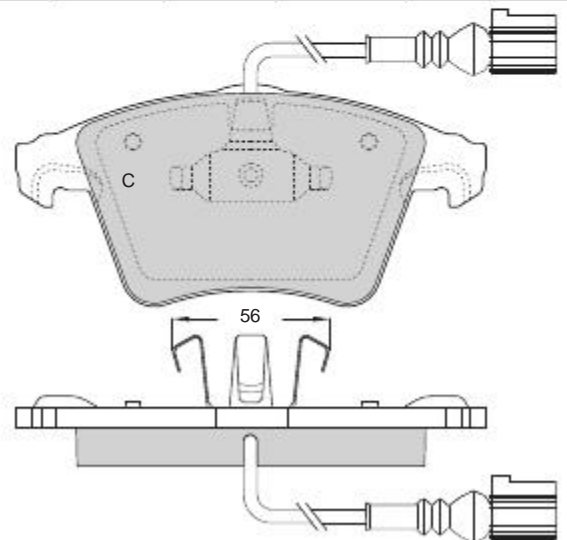
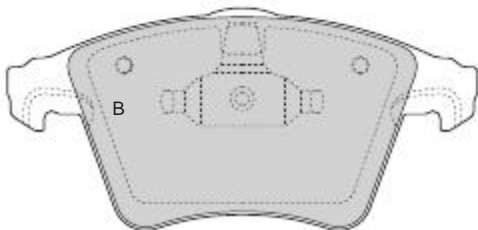

1507	ALFA ROMEO - FIAT LANCIA	BOSCH	X	150,8	57,8	19	2A-2B	2	220
------	-----------------------------	-------	---	-------	------	----	-------	---	-----



1508	VOLKSWAGEN	ATE	X	A 156,4 B-C 155,2	A 74,9 B-C 73,4	A 18,5 B-C 19,8	2A 1B-1C	1	200
------	------------	-----	---	----------------------	--------------------	--------------------	-------------	---	-----

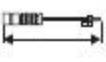

									
1509	BMW	ATE	X	122	A 59,2 B 58,2	17,3	2A-2B		

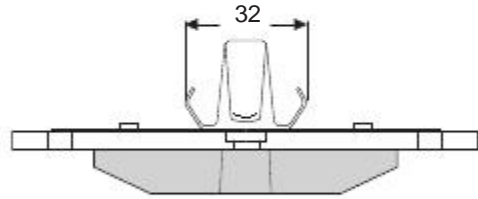
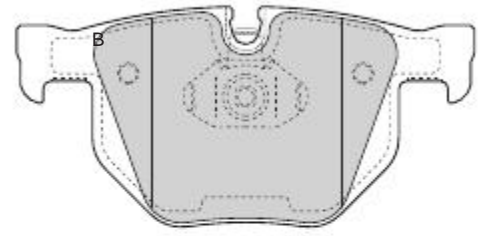
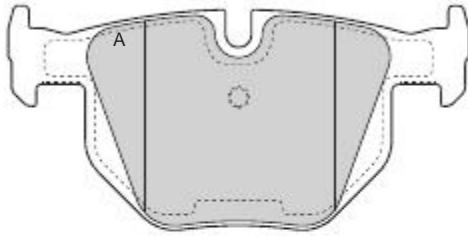



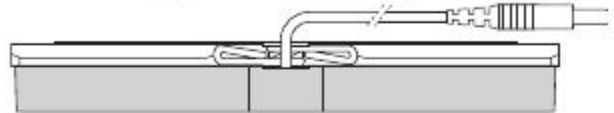
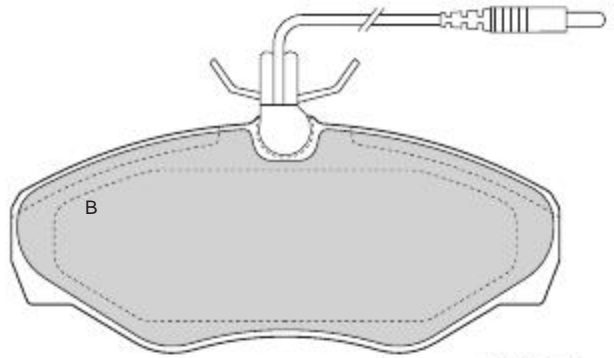
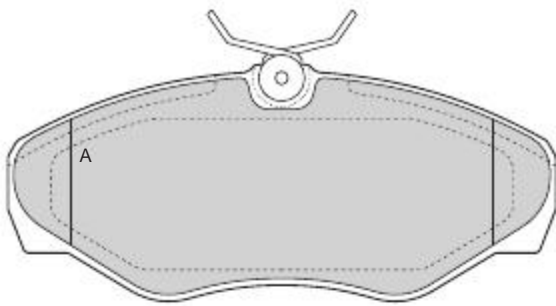



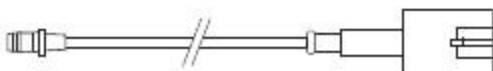
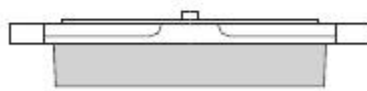



1510	RENAULT	TRW	X	144,8	62,5	18,4	3A-1B	1	310
------	---------	-----	---	-------	------	------	-------	---	-----



1511	ALFA ROMEO - FIAT LANCIA	BOSCH	X	94,8	42,8	17,5	4	2	163
------	-----------------------------	-------	---	------	------	------	---	---	-----



									
1512	DACIA - RENAULT	ATE	X	140,1	40	18	2A-2B		

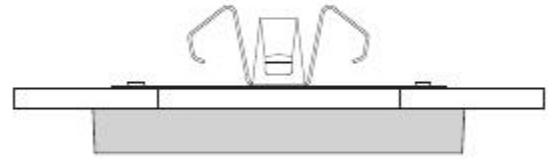
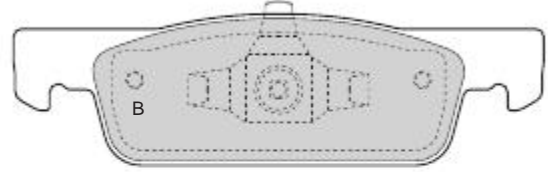
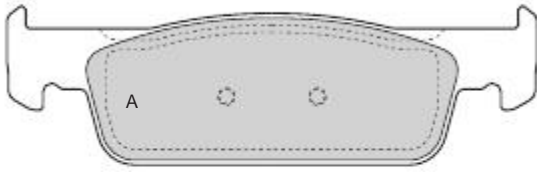



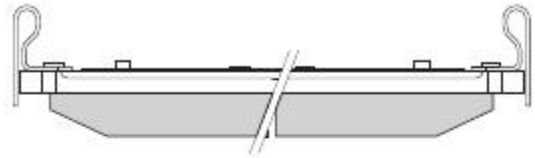
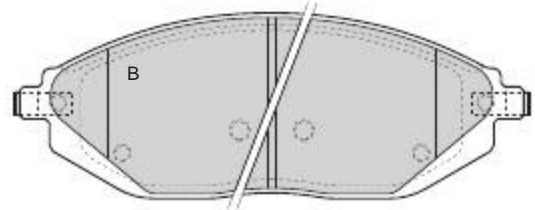
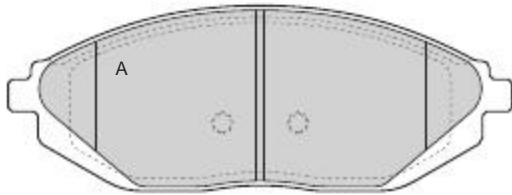



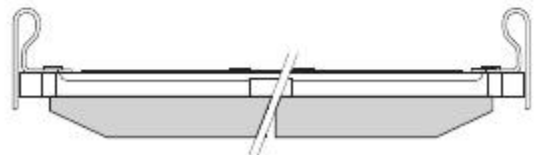
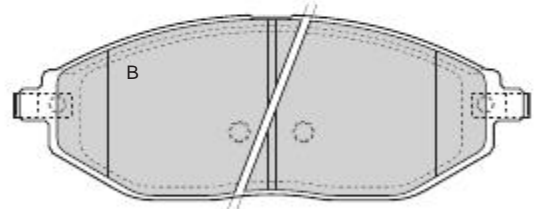
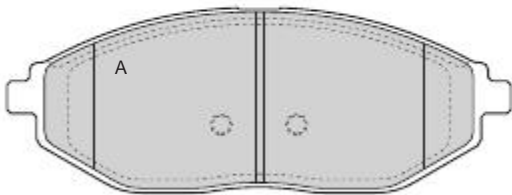



1513	CHEVROLET	AKEBONO	X	133,2	49	18	2A-2B		
------	-----------	---------	---	-------	----	----	-------	--	--



1514	CHEVROLET	AKEBONO	X	133,2	49	17,6	2A-2B		
------	-----------	---------	---	-------	----	------	-------	--	--



									
1515	AUDI	TRW	X	187,8	A 72,9 B 73,5	19	2A-2B	1	295

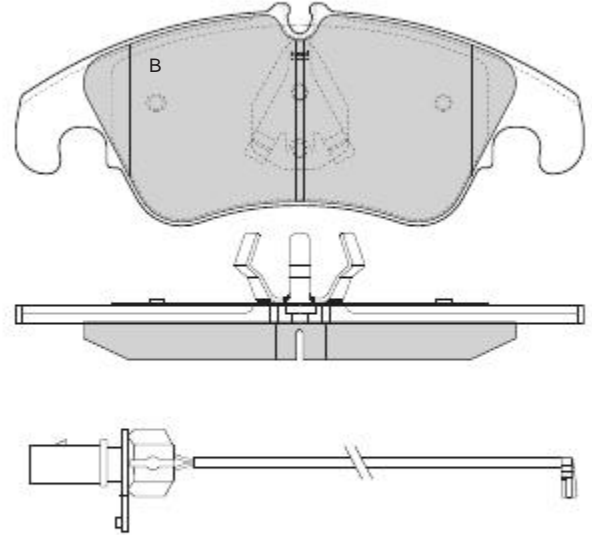
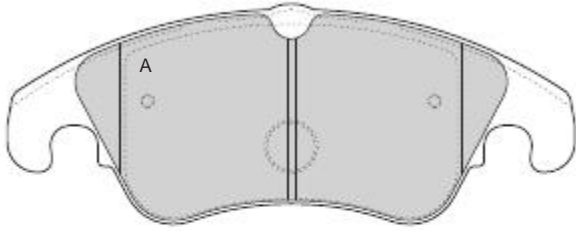



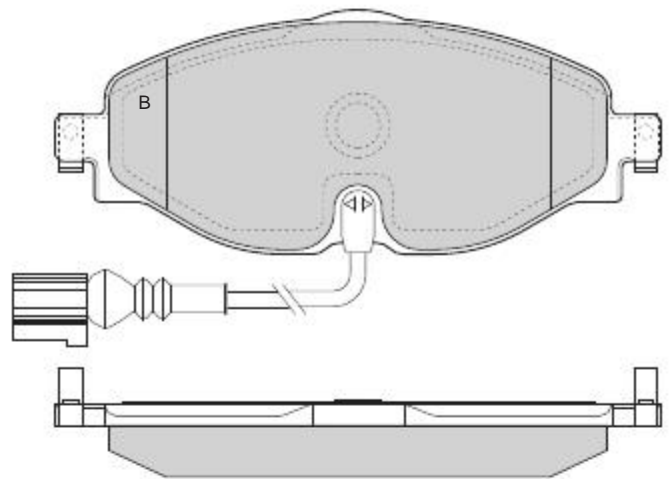
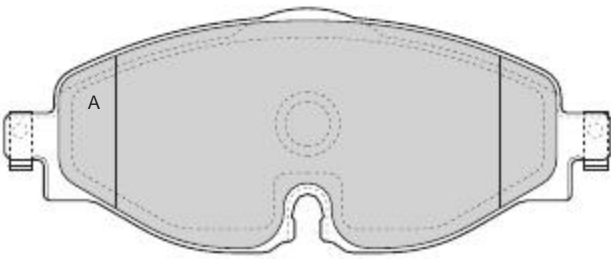



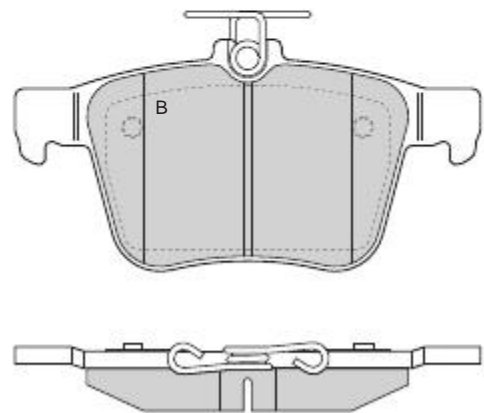
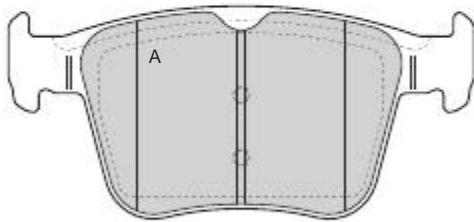

1516	AUDI - SEAT - VOLKSWAGEN	TRW	X	160,2	64,5	19,9	3A-1B	1	170
------	--------------------------	-----	---	-------	------	------	-------	---	-----



1517	AUDI - SEAT - VOLKSWAGEN	ATE	X	123	A 56,2 B 61,2	16,5	2A-2B		
------	--------------------------	-----	---	-----	------------------	------	-------	--	--

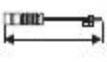

									
1518	AUDI - SEAT - VOLKSWAGEN	ATE	X	123	A 56,2 B 61,2	16,5	2A-2B		

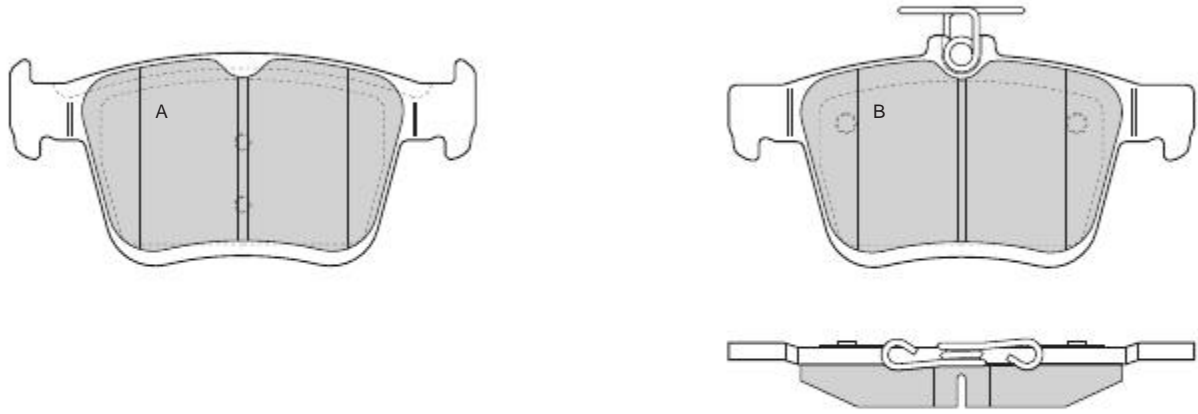



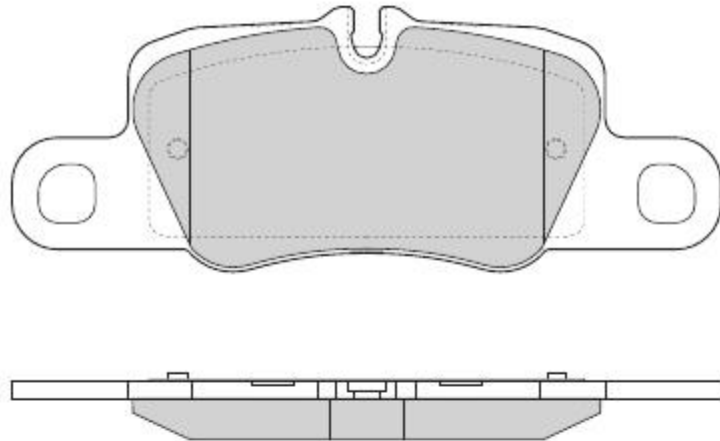



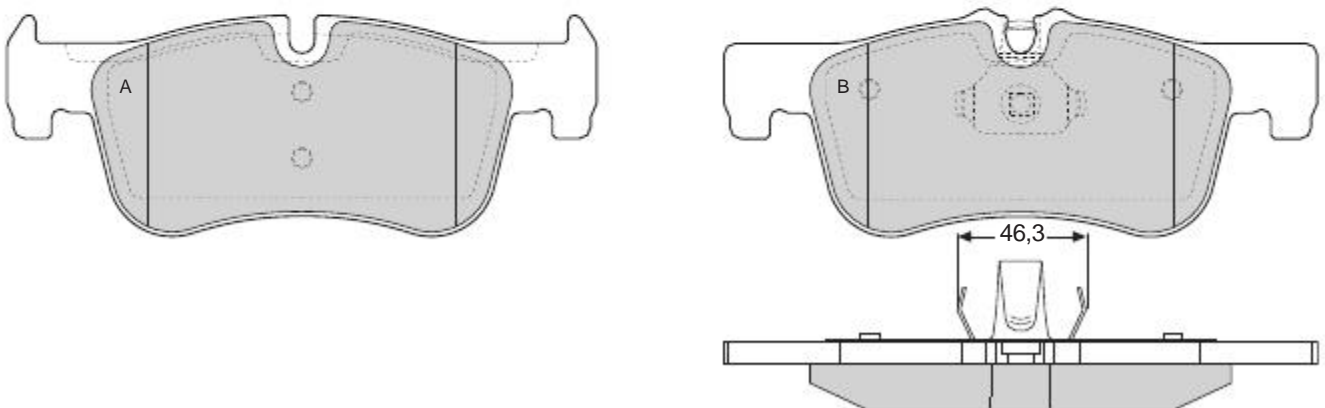



1519	PORSCHE	BREMBO	X	187,4	69,9	16	4		
------	---------	--------	---	-------	------	----	---	--	--



1520	BMW	ATE	X	A 155,8 B 156,8	A 58 B 60	18,4	2A-2B		
------	-----	-----	---	--------------------	--------------	------	-------	--	--



									
1521	BMW	BREMBO	X	73,6	88,4	17,2	4		

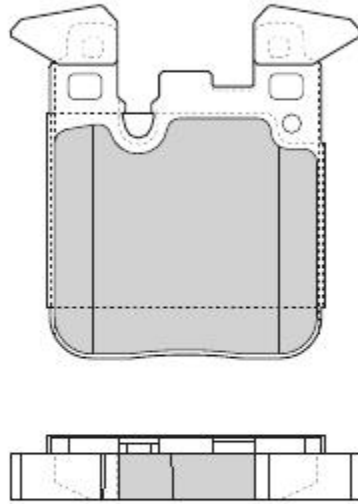



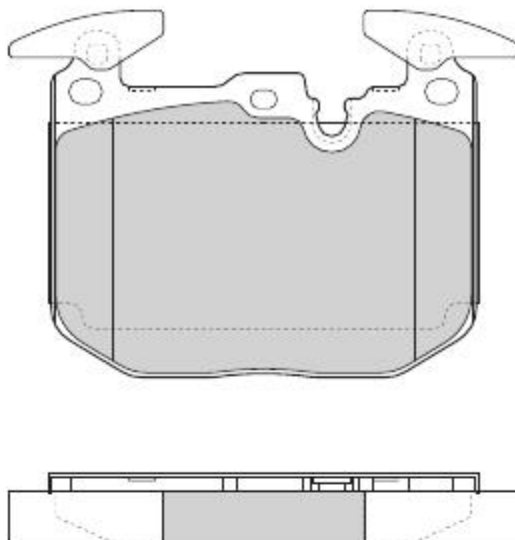



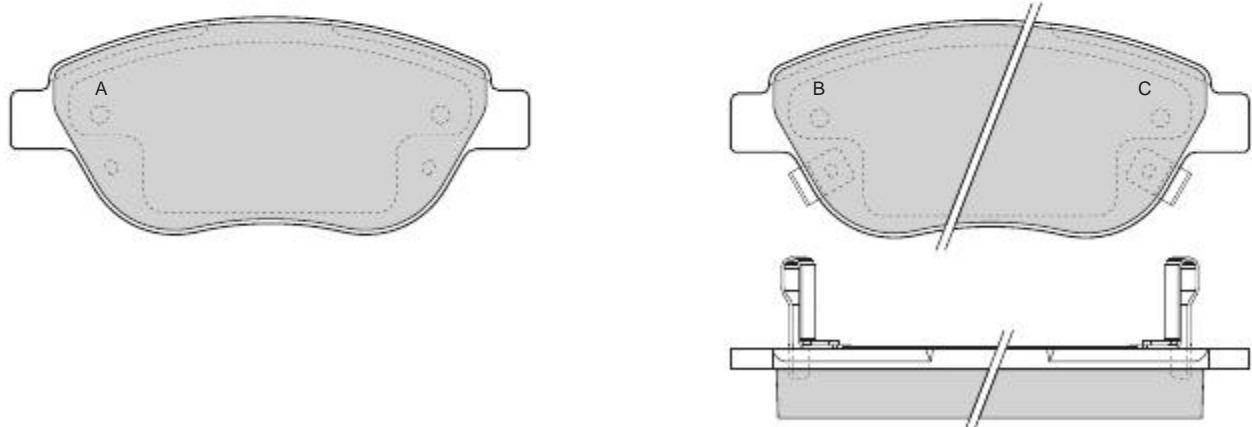



1522	BMW	BREMBO	X	113,9	91,4	18,2	4		
------	-----	--------	---	-------	------	------	---	--	--



1523	FIAT	BOSCH	X	136,8	57,9	19,2	2A 1B-1C		
------	------	-------	---	-------	------	------	-------------	--	--



									
1524	FIAT	TRW	X	95,8	43,9	17,1	2A 1B-1C		

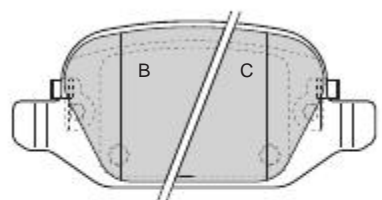
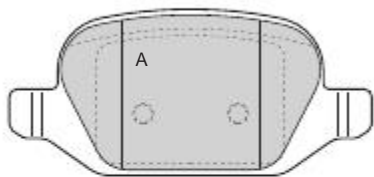



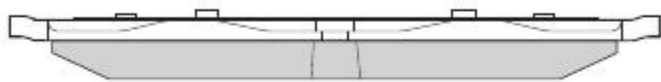
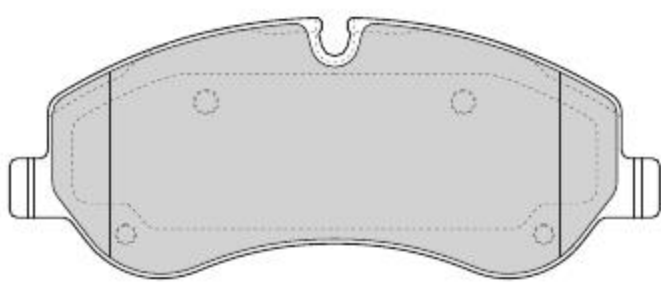



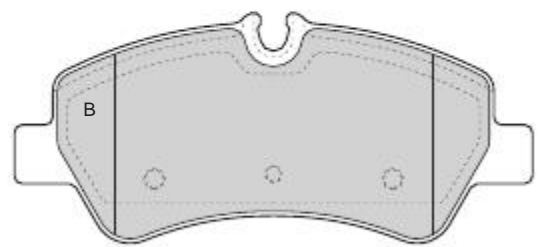
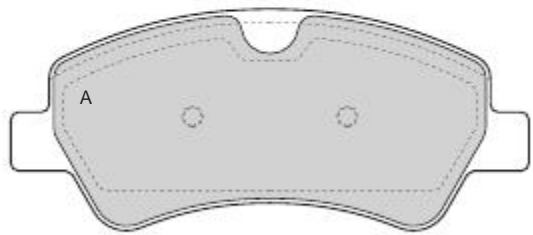

1525	FORD	BREMBO	X	171,8	68,8	16,4	4		
------	------	--------	---	-------	------	------	---	--	--



1526	FORD	BREMBO	X	136,9	A 58,5 B 60,8	17,4	2A-2B		
------	------	--------	---	-------	------------------	------	-------	--	--



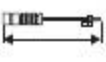

									
1527	FORD	WAGNER	X	194	68	15,5	2A 1B-1C		

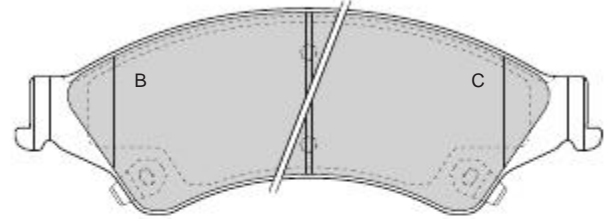
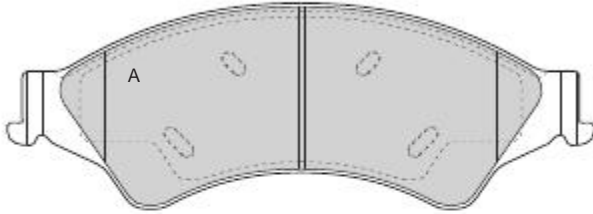



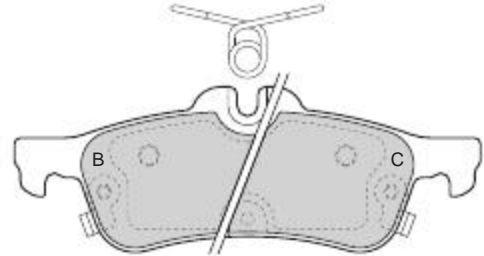
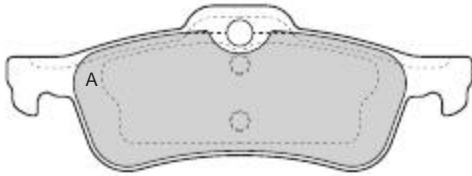



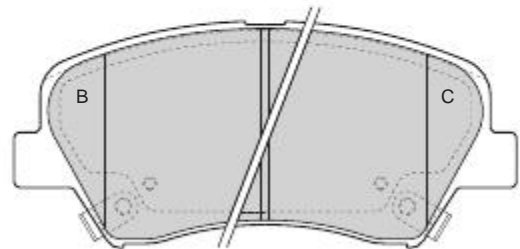
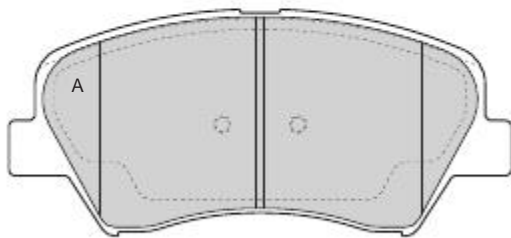



1528	HONDA	ATE	X	123,1	43,7	14,8	2A 1B-1C		
------	-------	-----	---	-------	------	------	-------------	--	--



1529	HYUNDAI	BOSCH	X	132,8	60	17,9	2A 1B-1C		
------	---------	-------	---	-------	----	------	-------------	--	--



									
1530	HYUNDAI	SUMITOMO	X	141	60	17,6	2A 1B-1C		

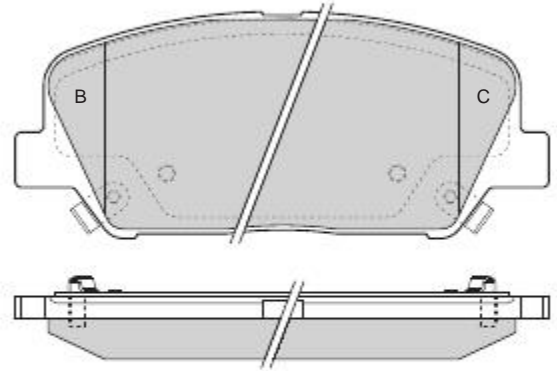
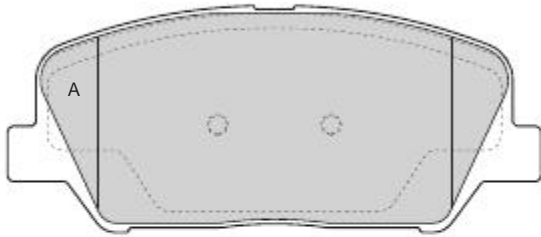



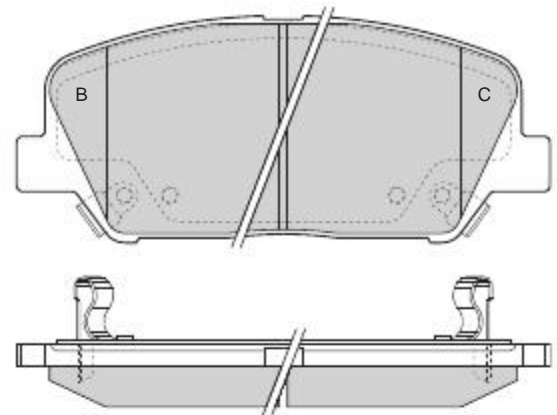
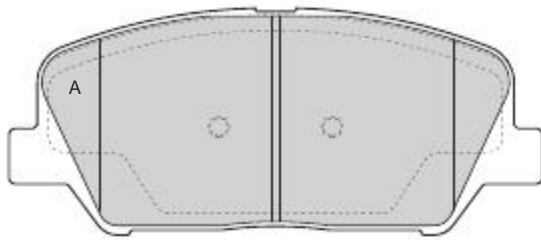



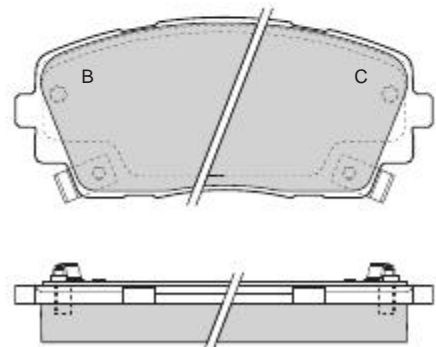
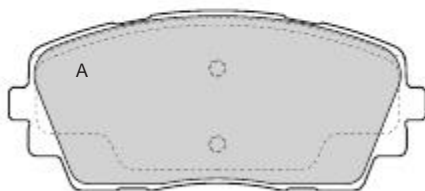



1531	HYUNDAI - KIA	SUMITOMO	X	141	60	17,6	2A 1B-1C		
------	---------------	----------	---	-----	----	------	-------------	--	--



1532	KIA	MANDO	X	110,2	47,6	16	2A 1B-1C		
------	-----	-------	---	-------	------	----	-------------	--	--



									
1533	LAND ROVER	TRW	X	131,4	58,6	16,4	4		

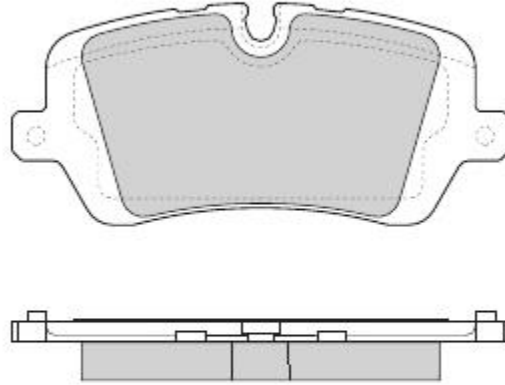



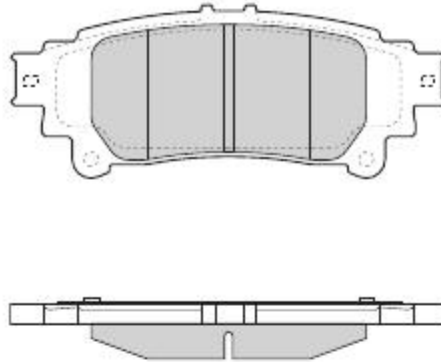



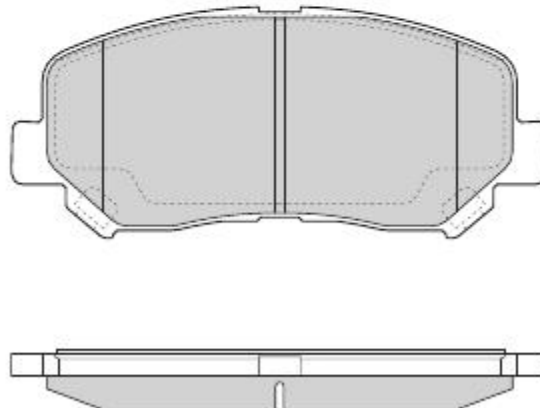



1534	LEXUS - TOYOTA	AKEBONO	X	115,2	45,7	15,2	4		
------	----------------	---------	---	-------	------	------	---	--	--



1535	MAZDA	AKEBONO	X	142	61,2	15,8	4		
------	-------	---------	---	-----	------	------	---	--	--



									
<b>1536</b>	MAZDA	AKEBONO	X	104,7	43,6	14,4	2A-2B		

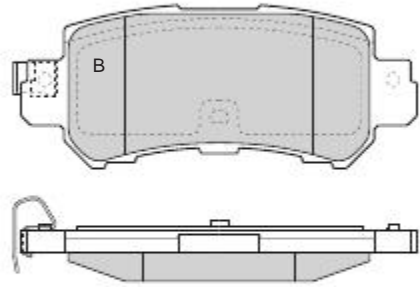
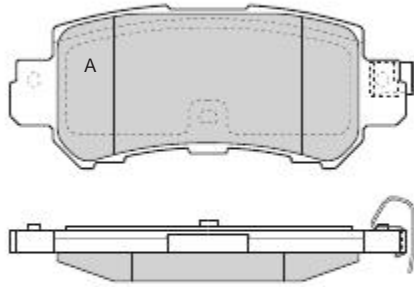



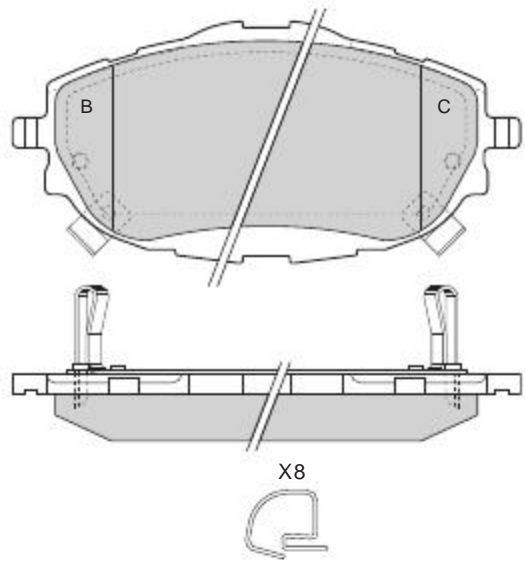
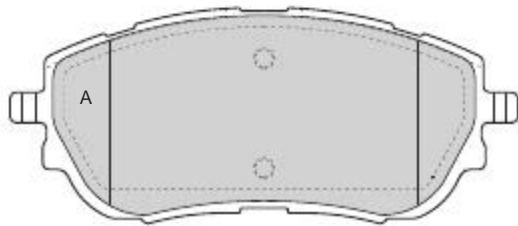



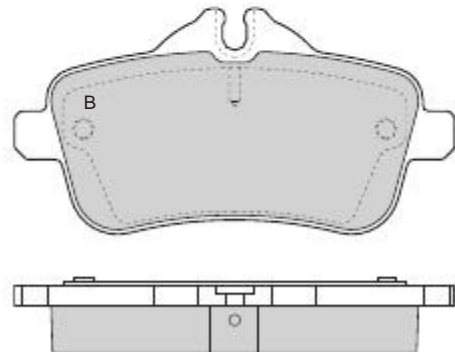
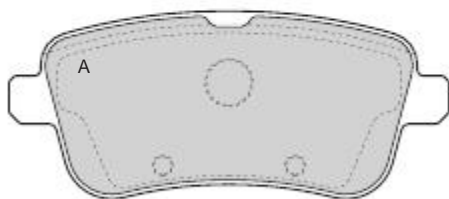



<b>1537</b>	TOYOTA	BOSCH	X	134,2	A 57,1 B-C 63,3	18,7	2A 1B-1C		
-------------	--------	-------	---	-------	--------------------	------	-------------	--	--



<b>1538</b>	MERCEDES	TRW	X	116,3	A 49,8 B 59,8	18,9	2A-2B		
-------------	----------	-----	---	-------	------------------	------	-------	--	--



									
1539	MERCEDES	TRW	X	116,3	A 49,8 B 59,8	16,5	2A-2B		

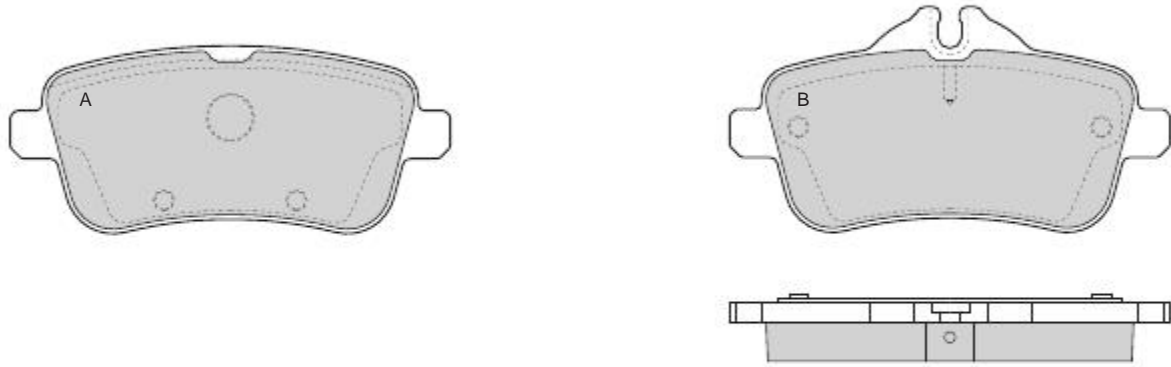



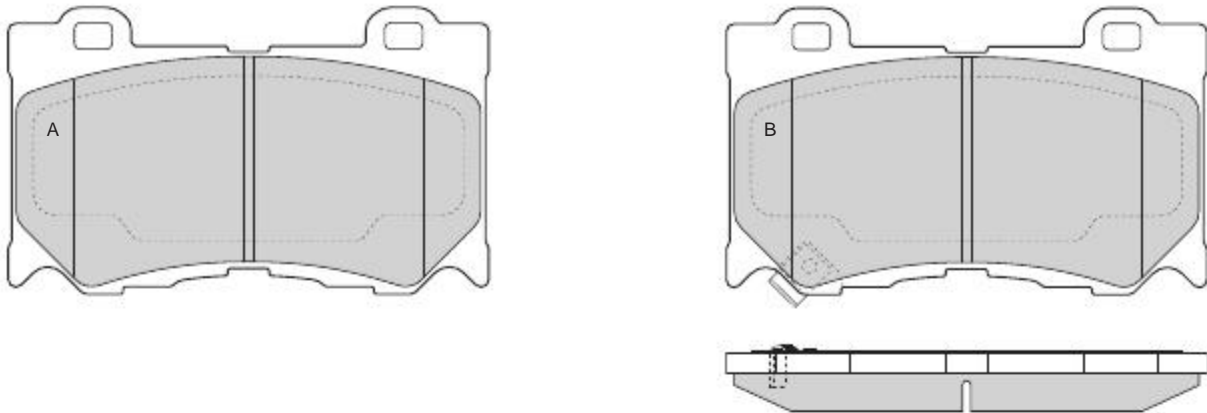



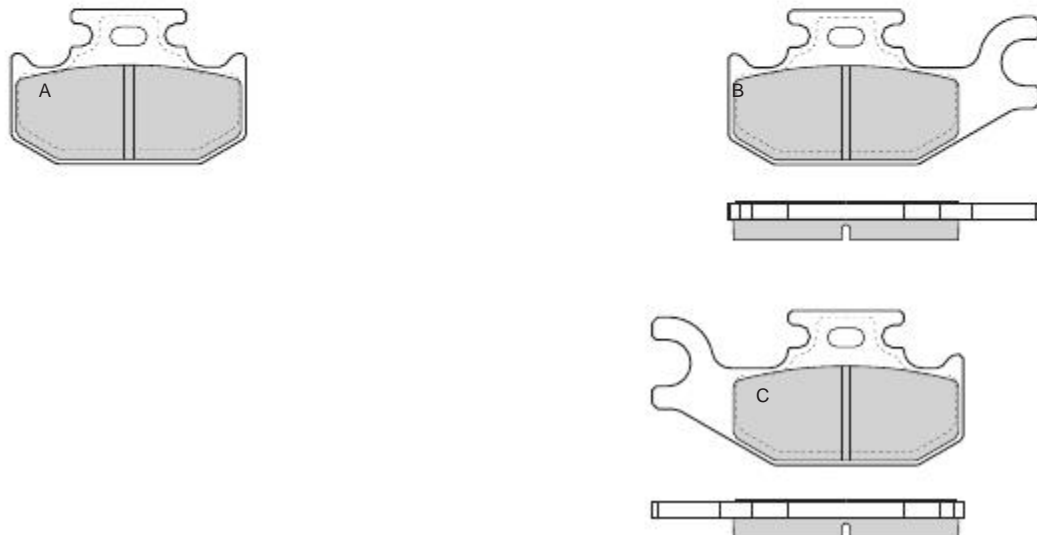



1540	INFINITY - NISSAN	AKEBONO	X	127	75,7	15,9	2A-2B		
------	-------------------	---------	---	-----	------	------	-------	--	--



1541	RENAULT		X	A 62,0 B-C 82,2	40,8	10,3	2A 1B-1C		
------	---------	--	---	--------------------	------	------	-------------	--	--



									
1542	RENAULT	TRW	X	62,5	26,7	9,1	4		

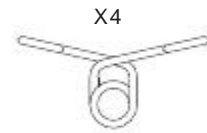
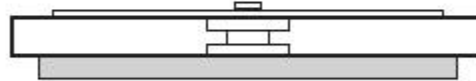
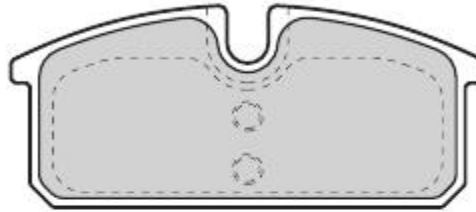





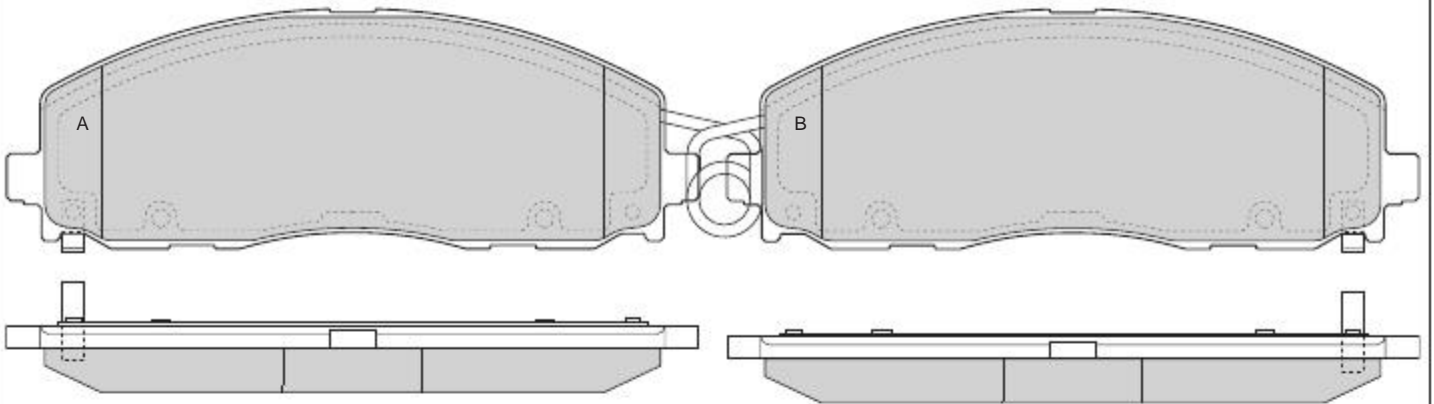



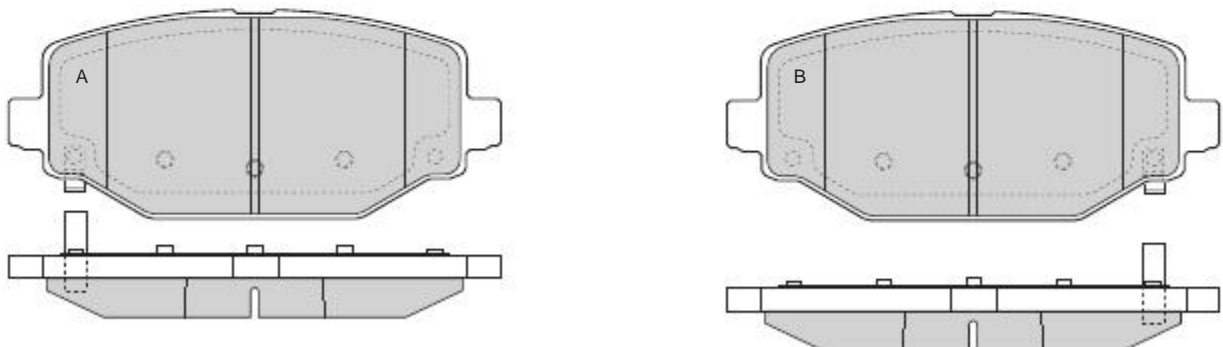

100%

1543	CHRYSLER - LANCIA	AKEBONO	X	183,1	63,5	18,5	2A-2B		
------	-------------------	---------	---	-------	------	------	-------	--	--



1544	CHRYSLER - LANCIA	TRW	X	130,1	55,2	17,1	2A-2B		
------	-------------------	-----	---	-------	------	------	-------	--	--



									
1545	FORD	TRW	X	131,6	60	16,7	2A-2B		

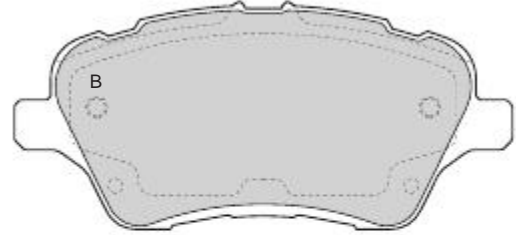
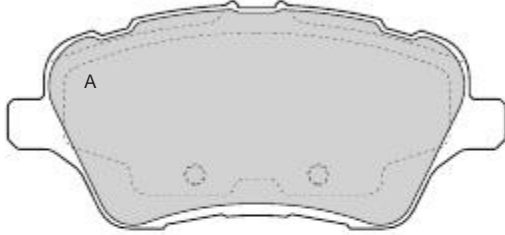



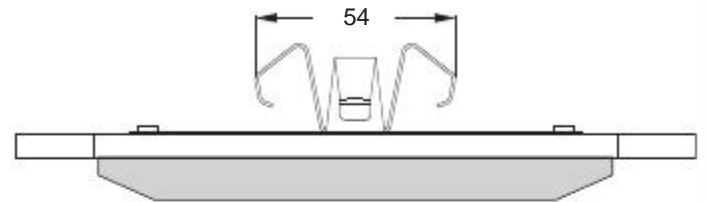



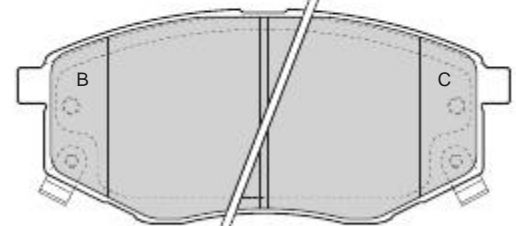
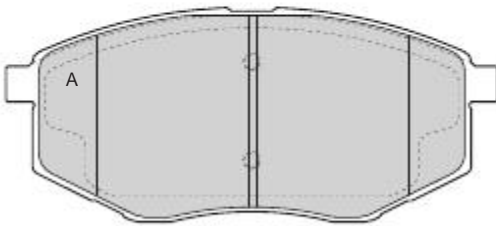

1546	FORD	ATE	X	180	65,4	18,1	2A-2B		
------	------	-----	---	-----	------	------	-------	--	--



1547	HYUNDAI - KIA	MANDO	X	130	56,7	16,8	2A 1B-1C		
------	---------------	-------	---	-----	------	------	-------------	--	--

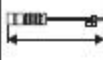

									
1548	KIA	MANDO	X	132,8	59	16,6	2A 1B-1C		

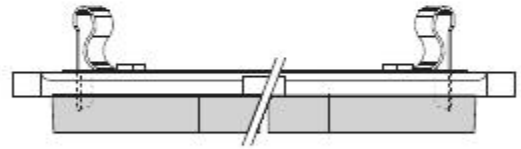
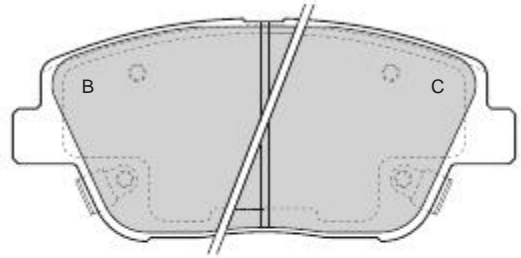
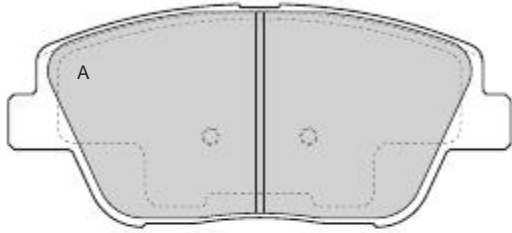



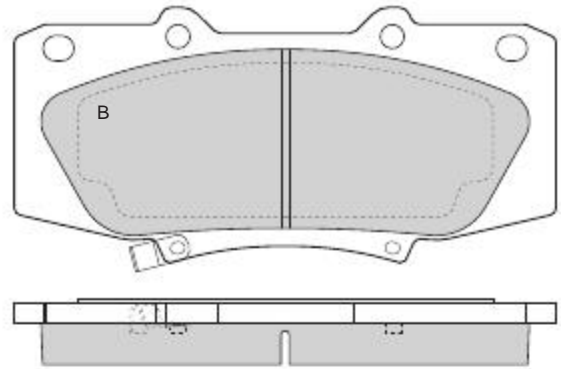
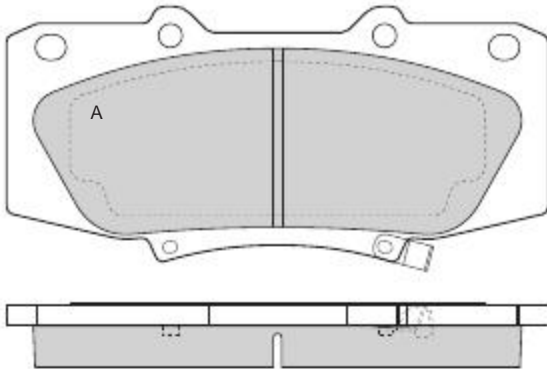



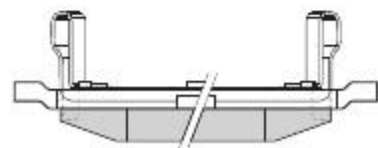
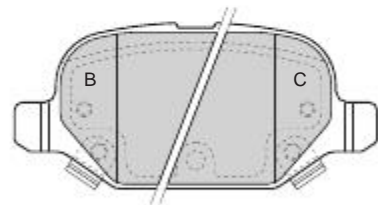
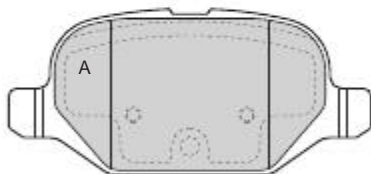



1549	TOYOTA	ADVICS	X	143,2	67,5	17,2	2A-2B		
------	--------	--------	---	-------	------	------	-------	--	--



1550	FIAT	TRW	X	95,8	43,9	14,4	2A 1B-1C		
------	------	-----	---	------	------	------	-------------	--	--





									
1551	MITSUBISHI	AKEBONO	X	139	58,9	19,5	1A 1B-6C		

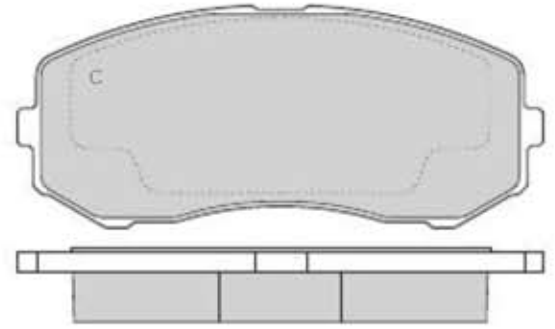
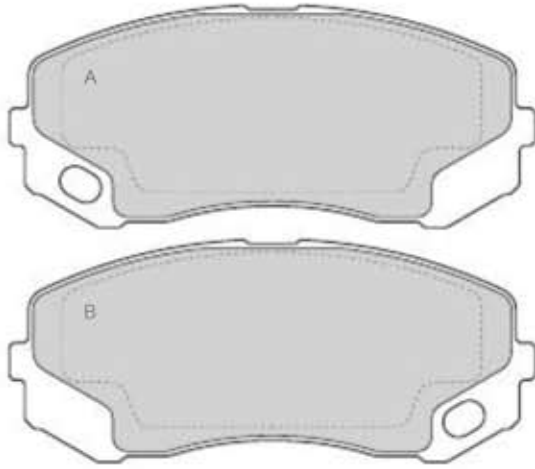



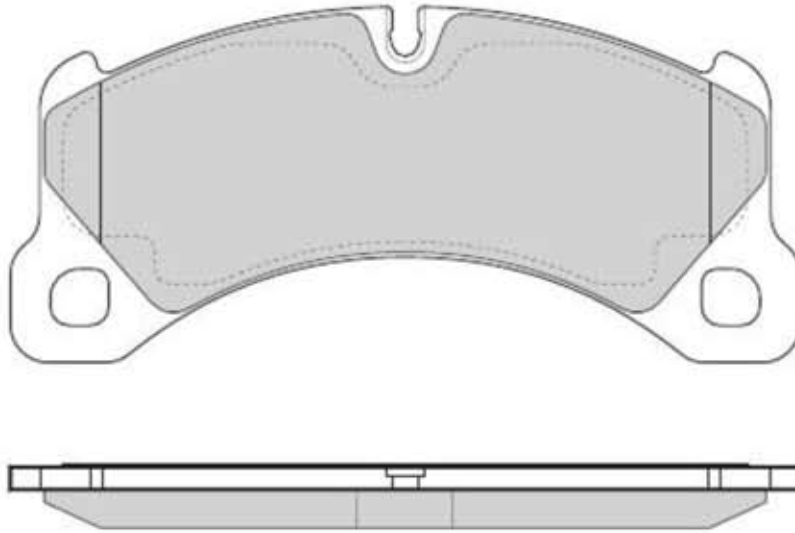



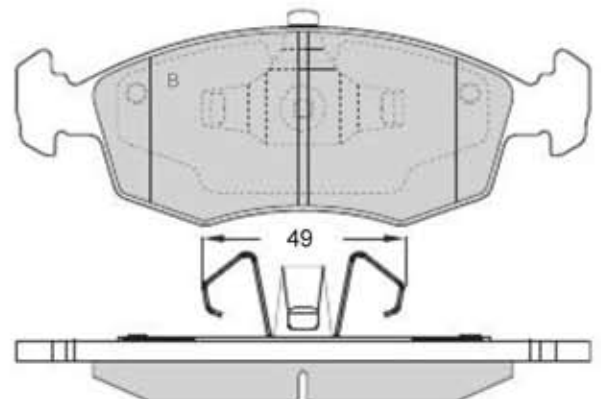
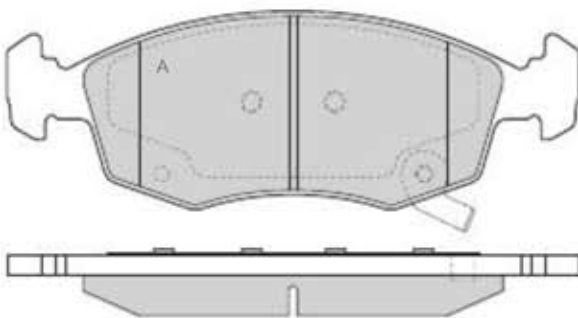

1552	PORSCHE	BREMBO	X	209,5	94,4	17	4		
------	---------	--------	---	-------	------	----	---	--	--



1553	FIAT	ATE	X	151,4	52,5	17	2A-2B		
------	------	-----	---	-------	------	----	-------	--	--

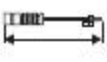

									
1554	MAZDA	AKEBONO	X	140,2	59,5	15,5	4		

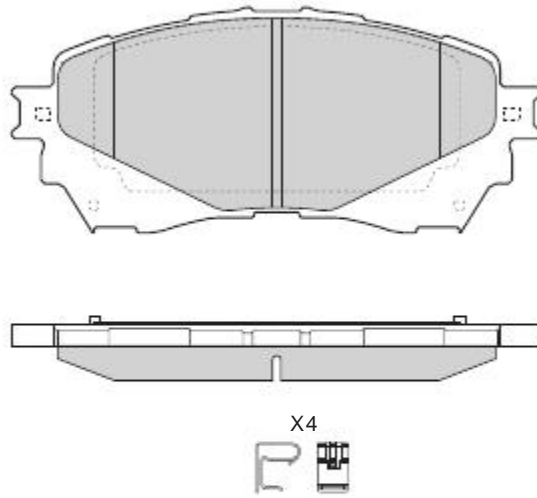







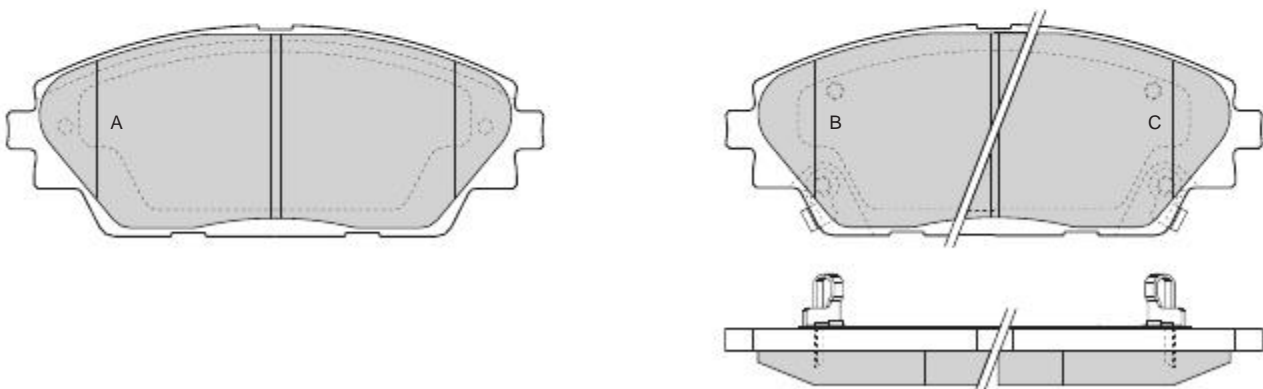



1555	MAZDA	AKEBONO	X	101,5	44,5	14,3	2A 1B-1C		
------	-------	---------	---	-------	------	------	-------------	--	--



1556	MAZDA	AKEBONO	X	141,8	55,8	15,8	2A 1B-1C		
------	-------	---------	---	-------	------	------	-------------	--	--



									
<b>1557</b>	MAZDA	AKEBONO	X	101,5	44,8	13,8	2A 1B-1C		

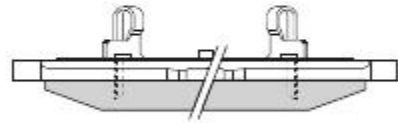
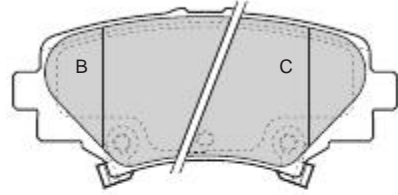
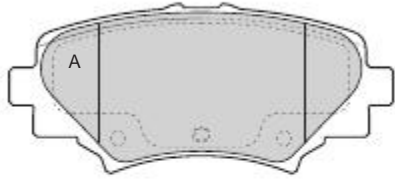



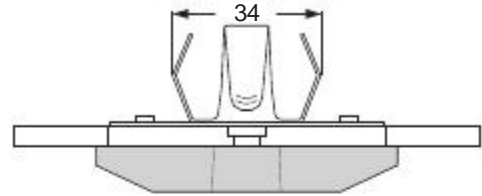
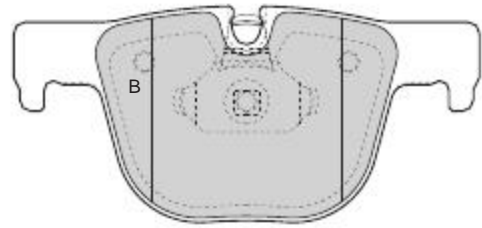
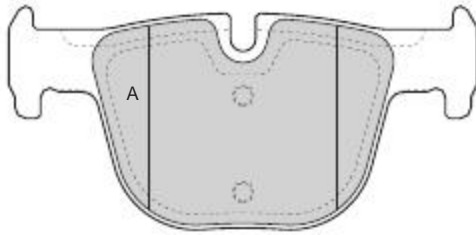



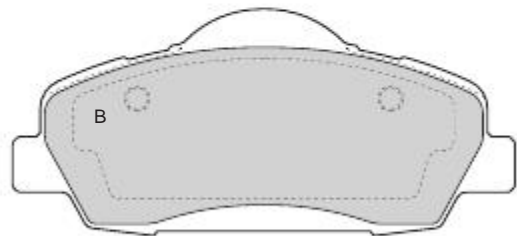
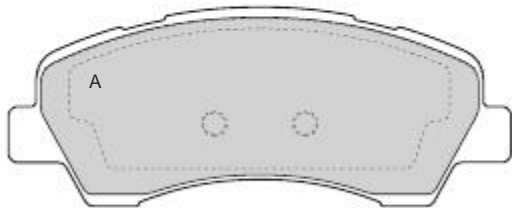

<b>1558</b>	BMW	ATE	X	A 123,8 B 123,1	A 59 B 57,3	18,3	2A-2B		
-------------	-----	-----	---	--------------------	----------------	------	-------	--	--



<b>1559</b>	CITROEN - PEUGEOT	MANDO		132,8	A 52,5 B 60,2	18	2A-2B		
-------------	-------------------	-------	--	-------	------------------	----	-------	--	--

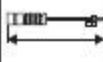

									
1560	PEUGEOT	BOSCH	X	147,8	A 58,3 B 63,3	18,5	2A-2B		

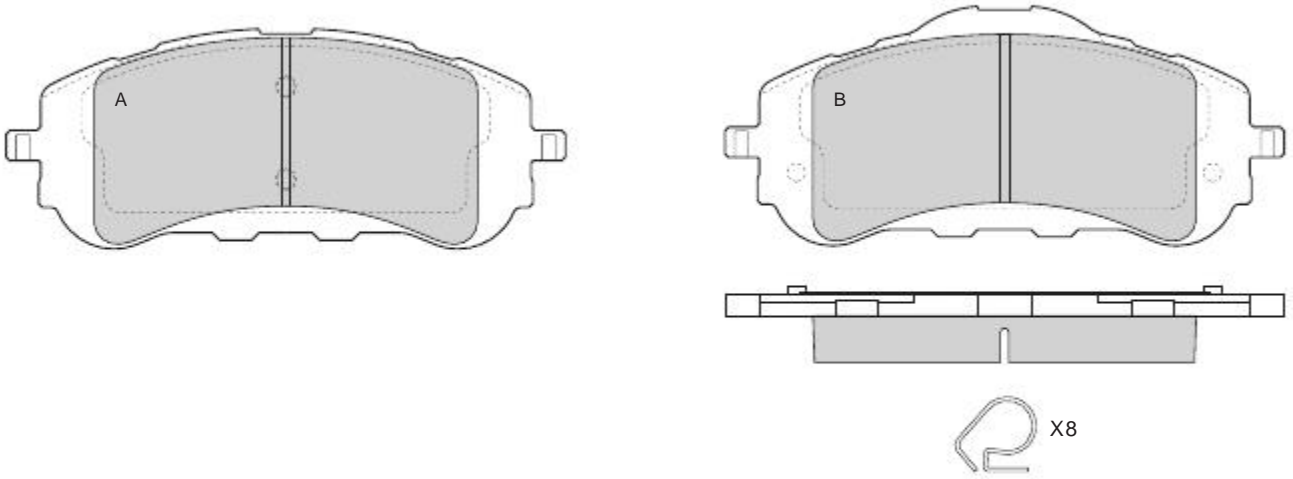



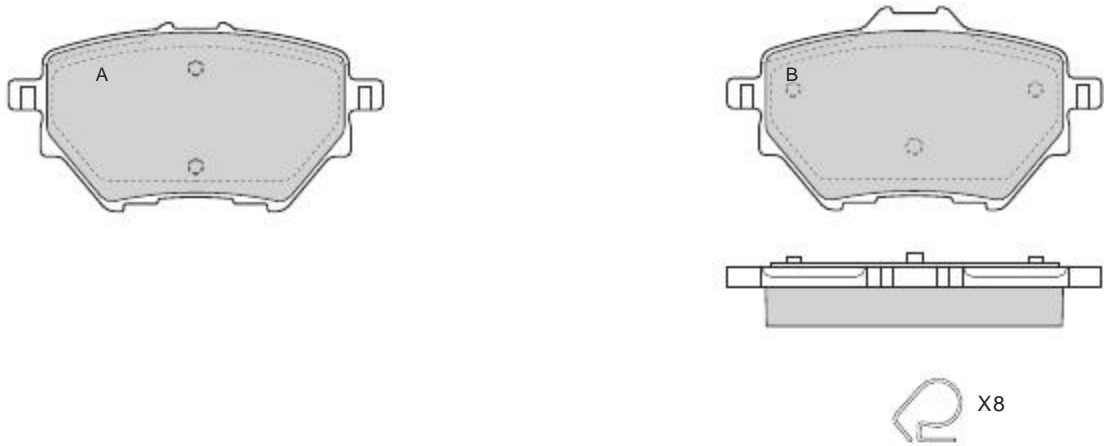



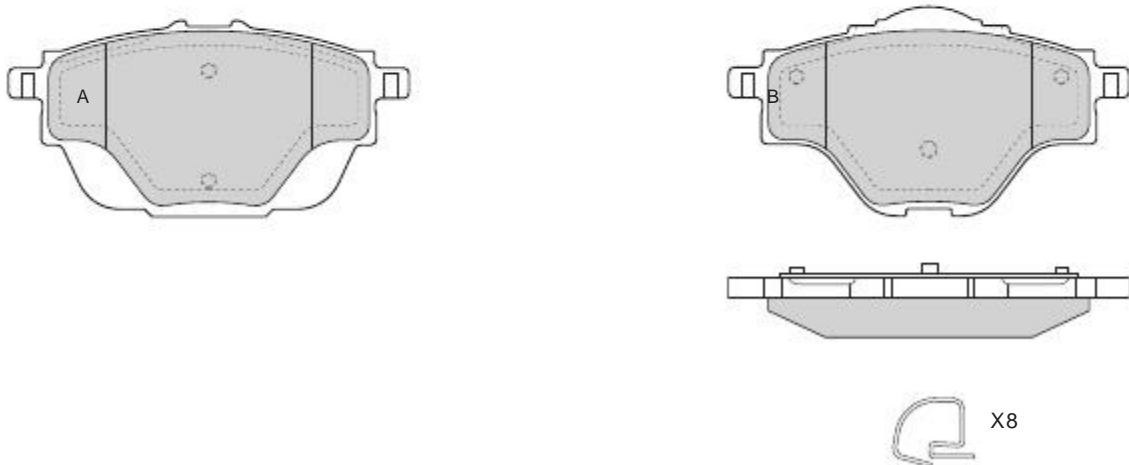



1561	CITROEN	BOSCH	X	99	A 49,8 B 53,5	16,7	2A-2B		
------	---------	-------	---	----	------------------	------	-------	--	--



1562	CITROEN - PEUGEOT	BOSCH	X	105,9	A 51,8 B 55,3	16,7	2A-2B		
------	-------------------	-------	---	-------	------------------	------	-------	--	--



									
<b>1563</b>	CITROEN	ATE	X	155,1	61,9	17	2A-2B		

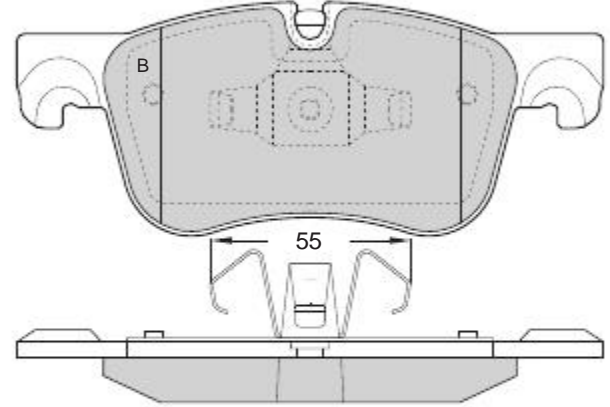
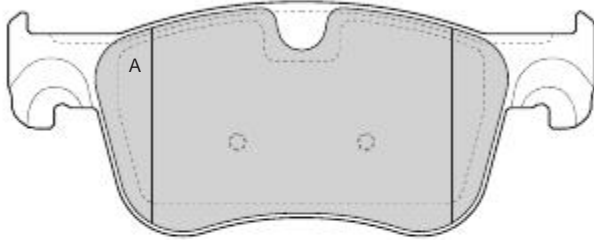



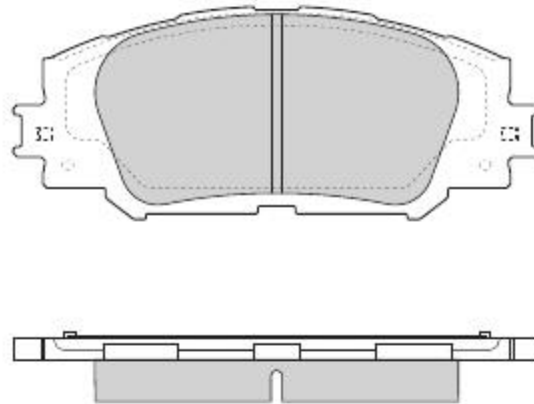



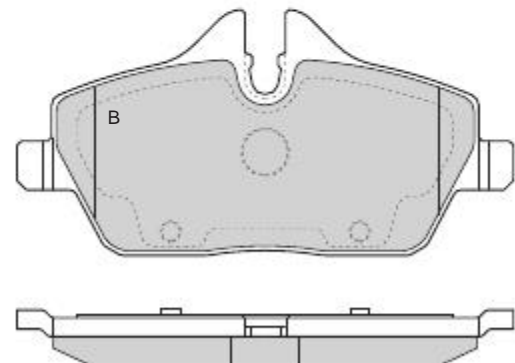
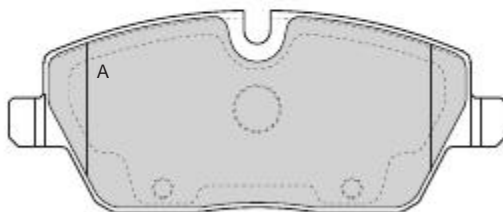



<b>1564</b>	TOYOTA	ADVICS	X	139,1	56	17,4	4		
-------------	--------	--------	---	-------	----	------	---	--	--



<b>1565</b>	BMW	TRW		131,4	A 53,2 B 65,3	13,7	2A-2B		
-------------	-----	-----	--	-------	------------------	------	-------	--	--



									
1566	BMW	ATE	X	123	A 46,8 B 47,9	16	2A-2B		

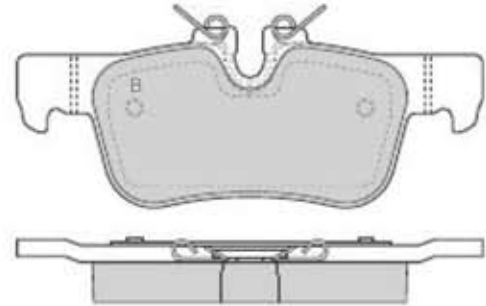
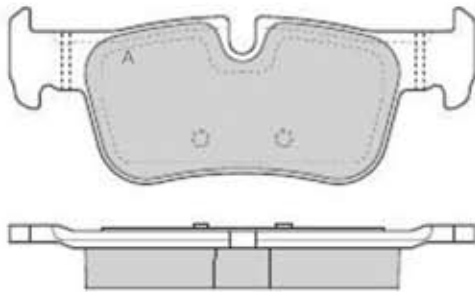



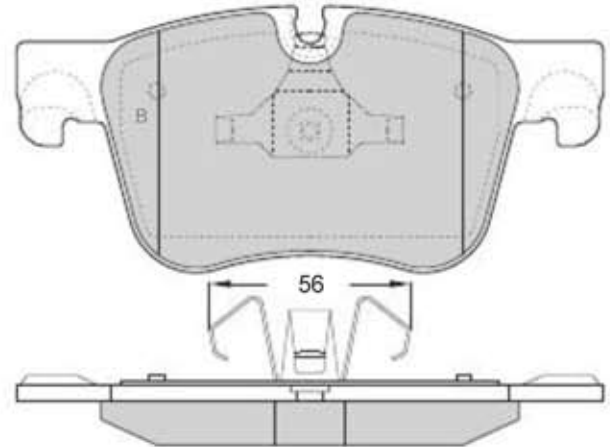



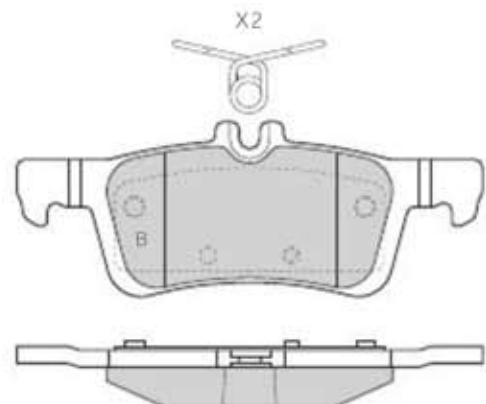
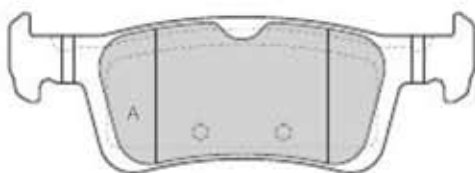

1567	CITROEN - PEUGEOT	ATE	X	155.1	A 70,5 B 70,4	1/	2A-2B		
------	-------------------	-----	---	-------	------------------	----	-------	--	--



1568	PEUGEOT	ATE	X	123	A 42,4 B 46,2	15,7	2A- 2B		
------	---------	-----	---	-----	------------------	------	--------	--	--

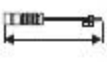

									
1569	TOYOTA	ADVICS	X	122,7	54,3	17,5	4		

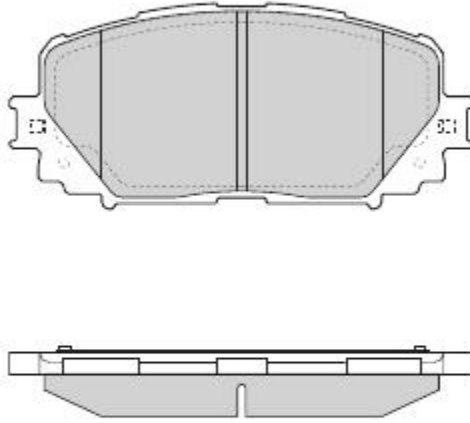



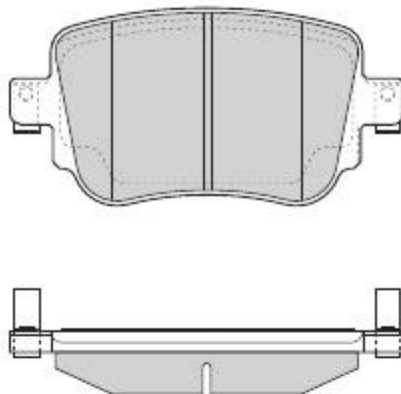



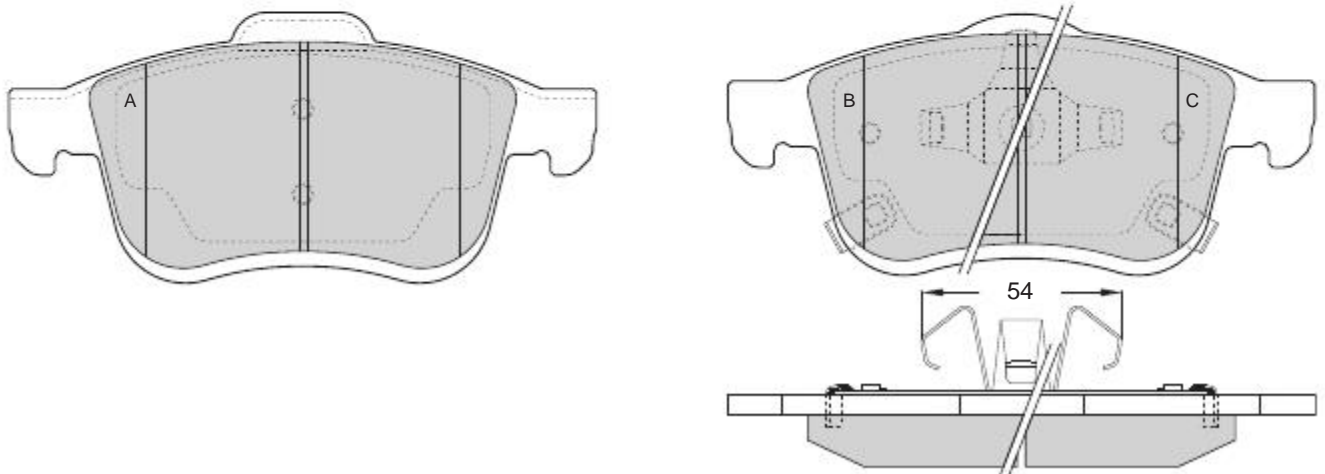

1570	SEAT - SKODA VOLKSWAGEN	TRW	X	104	52,2	17,4	4		
------	----------------------------	-----	---	-----	------	------	---	--	--



1571	FIAT	ATE	X	A 155,3 B-C 155,1	A 71,5 B-C 69	20	2A 1B-1C		
------	------	-----	---	----------------------	------------------	----	-------------	--	--

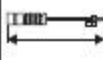

									
1572	FIAT	TRW	X	95,6	A 48,1 B-C 47,4	17,1	2A 1B-1C		

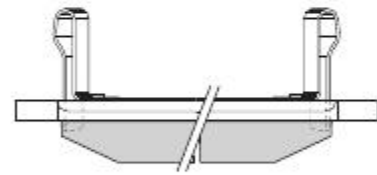
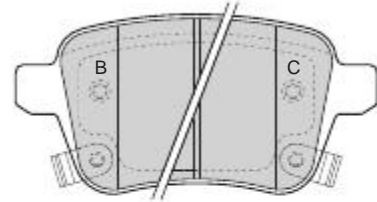
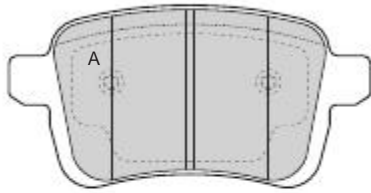



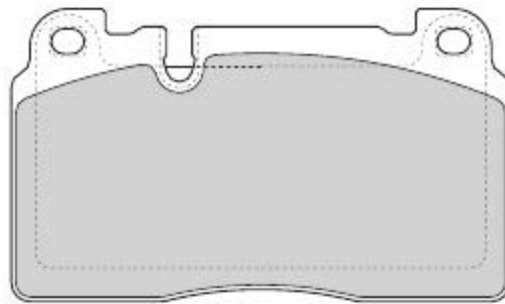



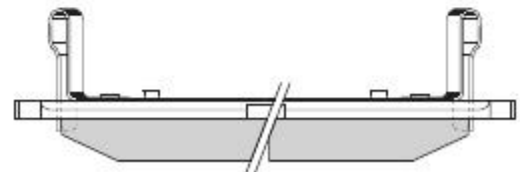
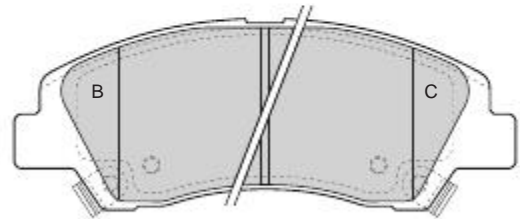
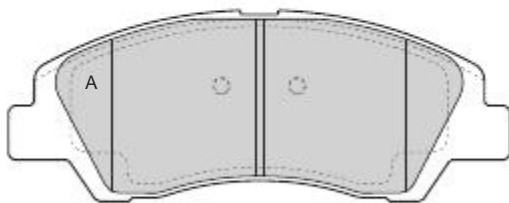



1573	AUDI	BREMBO	X	131,8	77,3	16,5	4		
------	------	--------	---	-------	------	------	---	--	--



1574	HYUNDAI	MANDO	X	132,5	50,6	16,8	2A 1B-1C		
------	---------	-------	---	-------	------	------	-------------	--	--





									
1575	CHEVROLET	MANDO	X	142	53,6	17,4	2A 1B-1C		

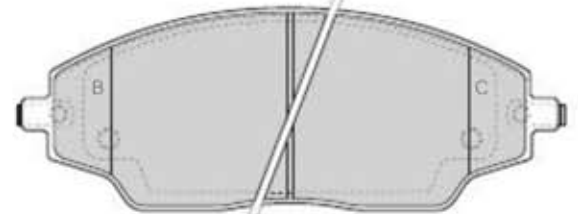
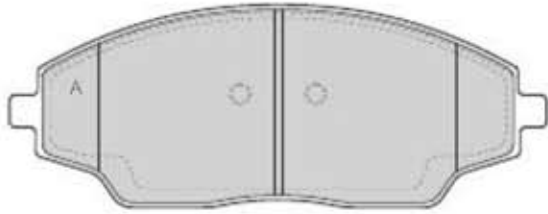



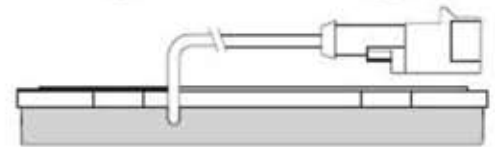
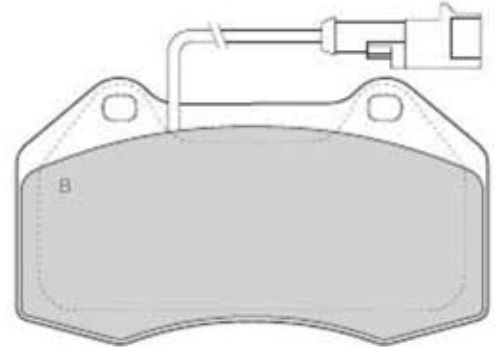
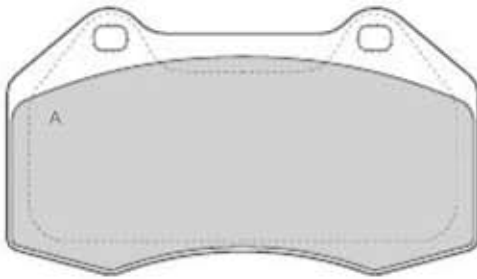



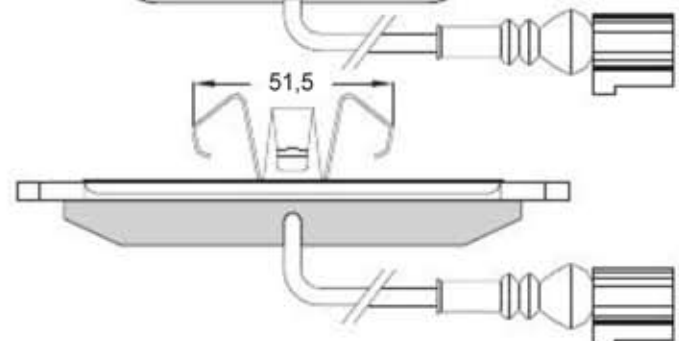
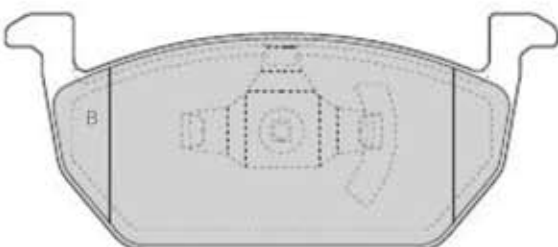
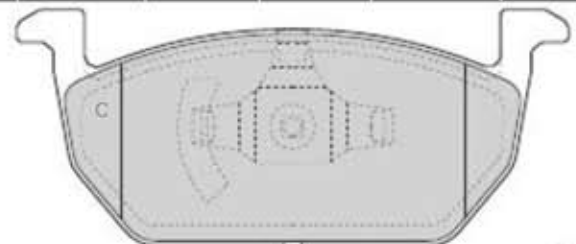
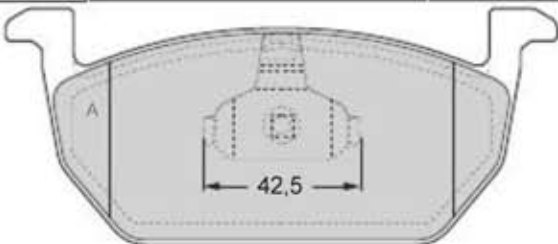



1576	ALFA ROMEO - FIAT	BREMBO	X	124,6	70,4	15,2	2A-2B	2	160
------	-------------------	--------	---	-------	------	------	-------	---	-----



1577	SEAT - SKODA VOLKSWAGEN	ATE		146	62,4	17,5	2A 1B-1C	1	155
------	----------------------------	-----	--	-----	------	------	-------------	---	-----



									
1578	TESLA	BREMBO	X	131,7	97	14,9	4		

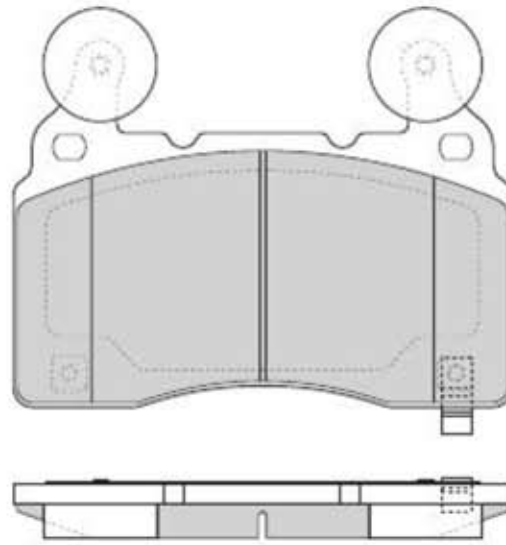



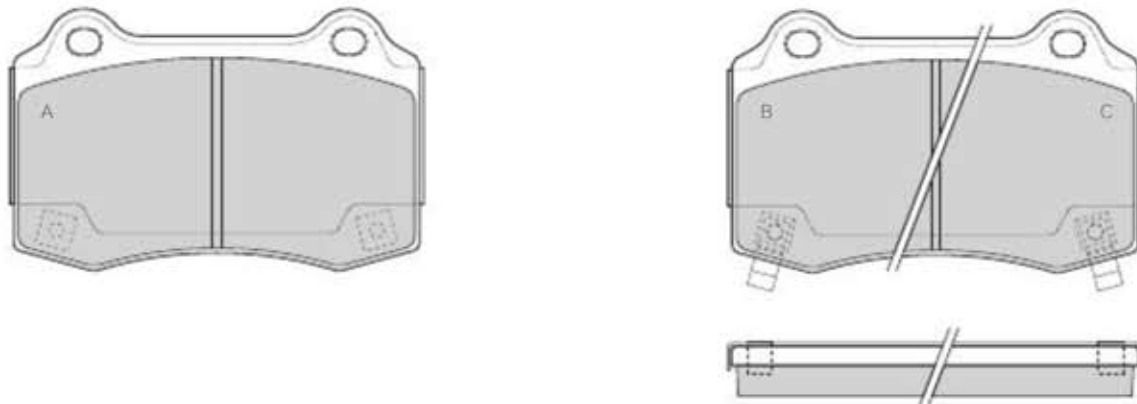



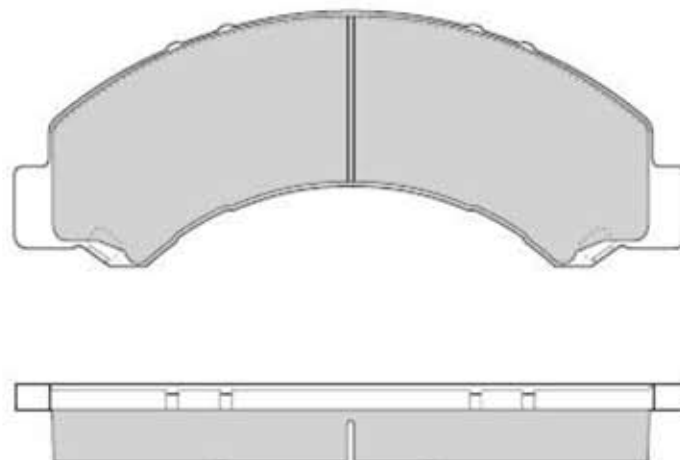



1579	HYUNDAI	BREMBO	X	109,4	69,3	14	2A 1B-1C		
------	---------	--------	---	-------	------	----	-------------	--	--



1580	ISUZU	AKEBONO	X	178	67,9	21	4		
------	-------	---------	---	-----	------	----	---	--	--



									
1581	NISSAN	AKEBONO	X	143,6	A 81,2 B-C 91,2	17,8	2A 1B-1C		

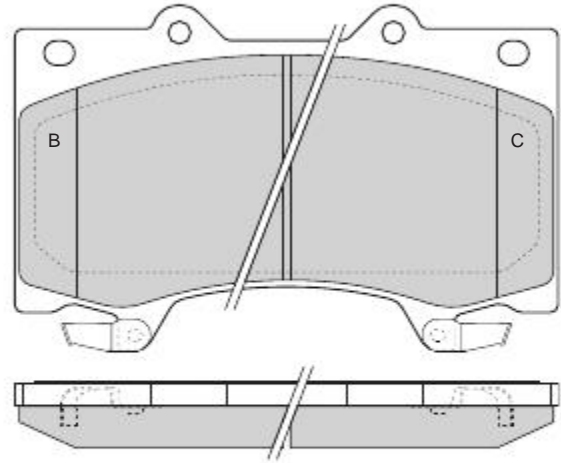
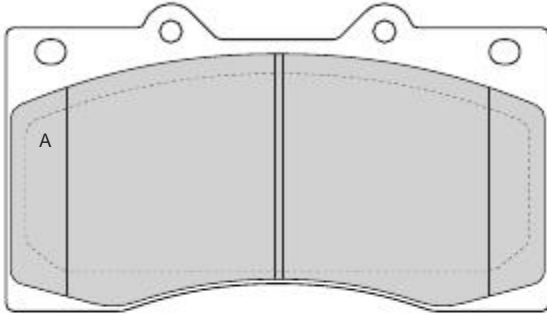



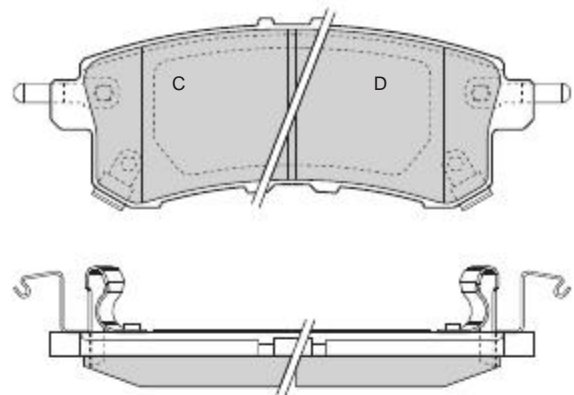
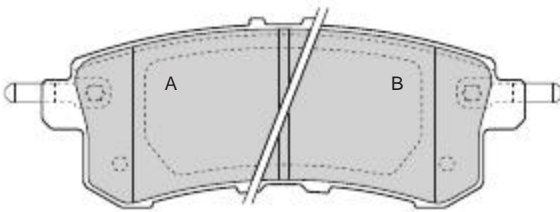



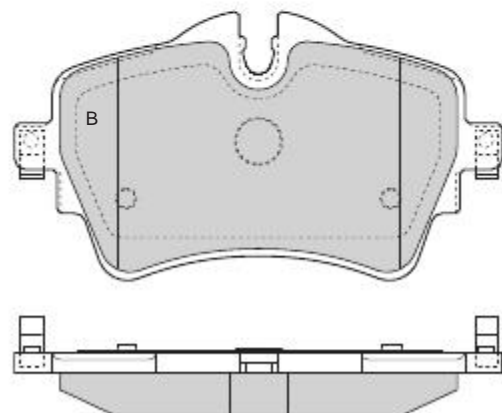
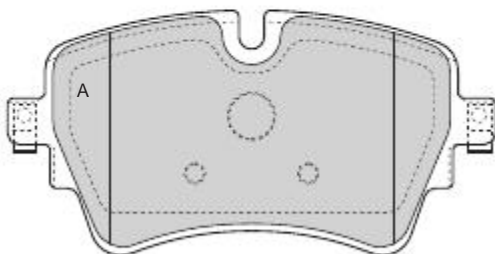

1582	INFINITI - NISSAN		X	127,6	50	15	1A-1B 1C-1D		
------	-------------------	--	---	-------	----	----	----------------	--	--



1583	BMW - MINI (BMW)	TRW		129	A 64,5 B 71,5	17,7	2A-2B		
------	------------------	-----	--	-----	------------------	------	-------	--	--

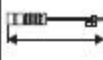

									
1584	MINI (BMW)	TRW	X	100	A 38,2 B 44,9	16,6	2A-2B		

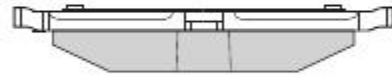
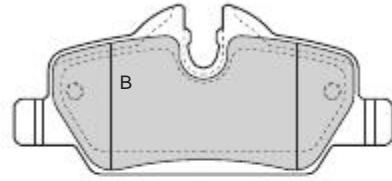
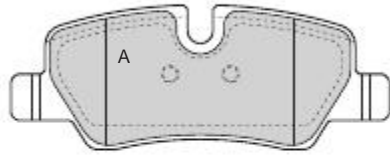



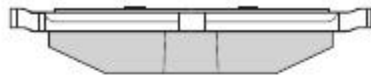
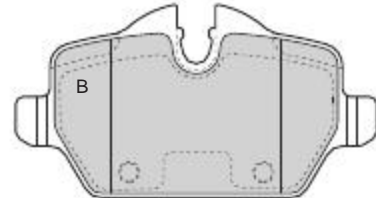
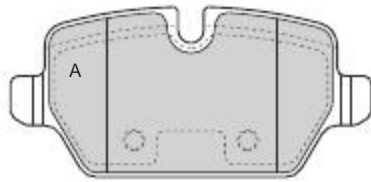



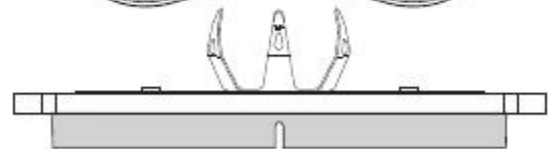
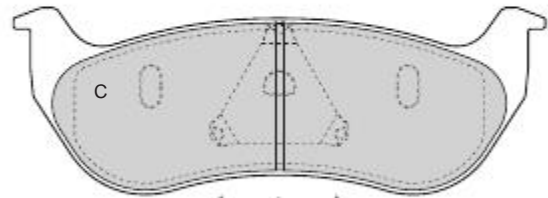
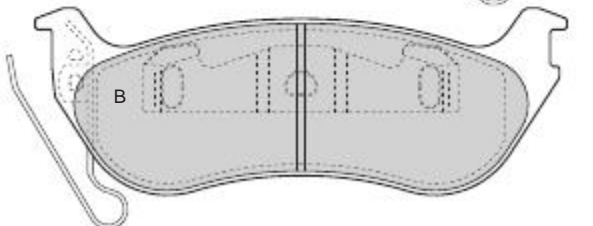
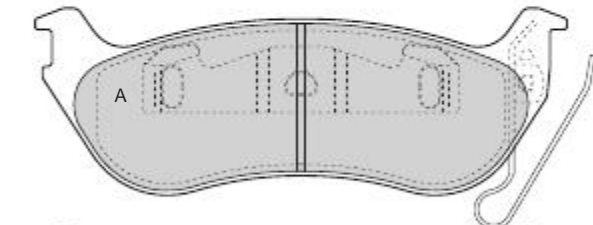

1585	MINI (BMW)	TRW	X	95,4	A 45 B 51,6	16,9	2A-2B		
------	------------	-----	---	------	----------------	------	-------	--	--



1586	JEEP	HELSEY HAYES	X	140,5	49,3	15	1A 1B-2C		
------	------	-----------------	---	-------	------	----	-------------	--	--

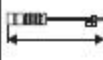

									
1587	FIAT - PEUGEOT	BREMBO	X	169,1	69,1	19,1	2A-2B	2	190

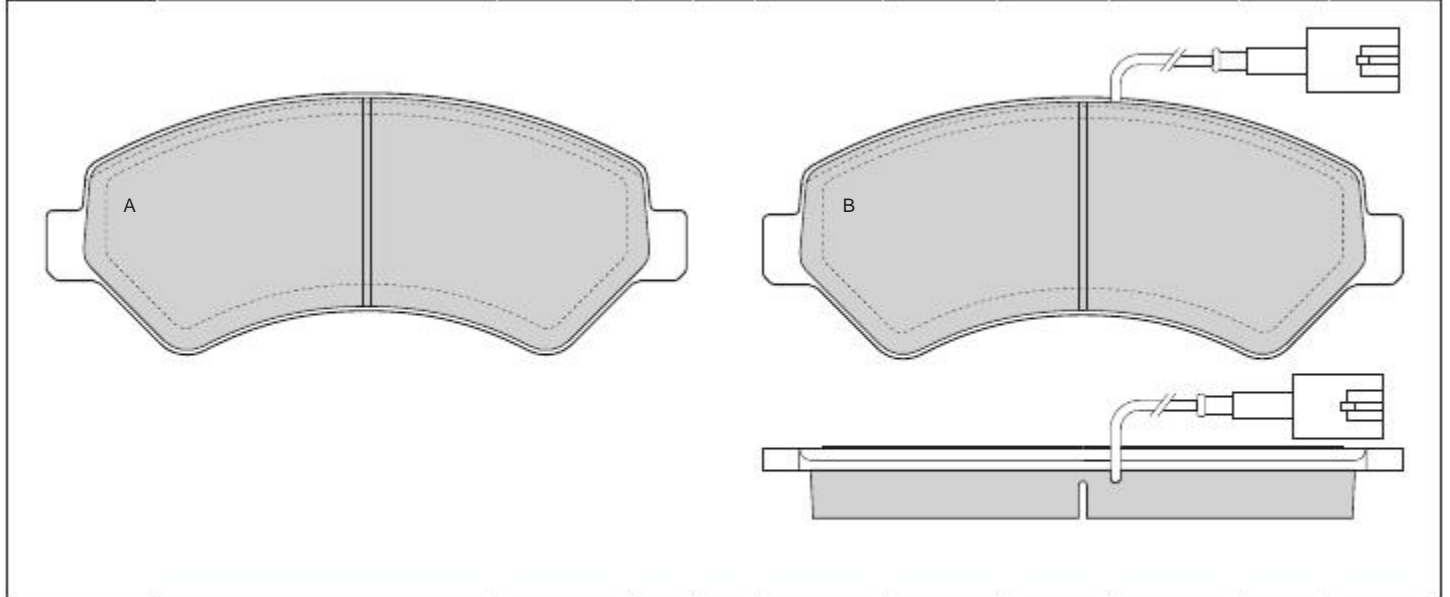



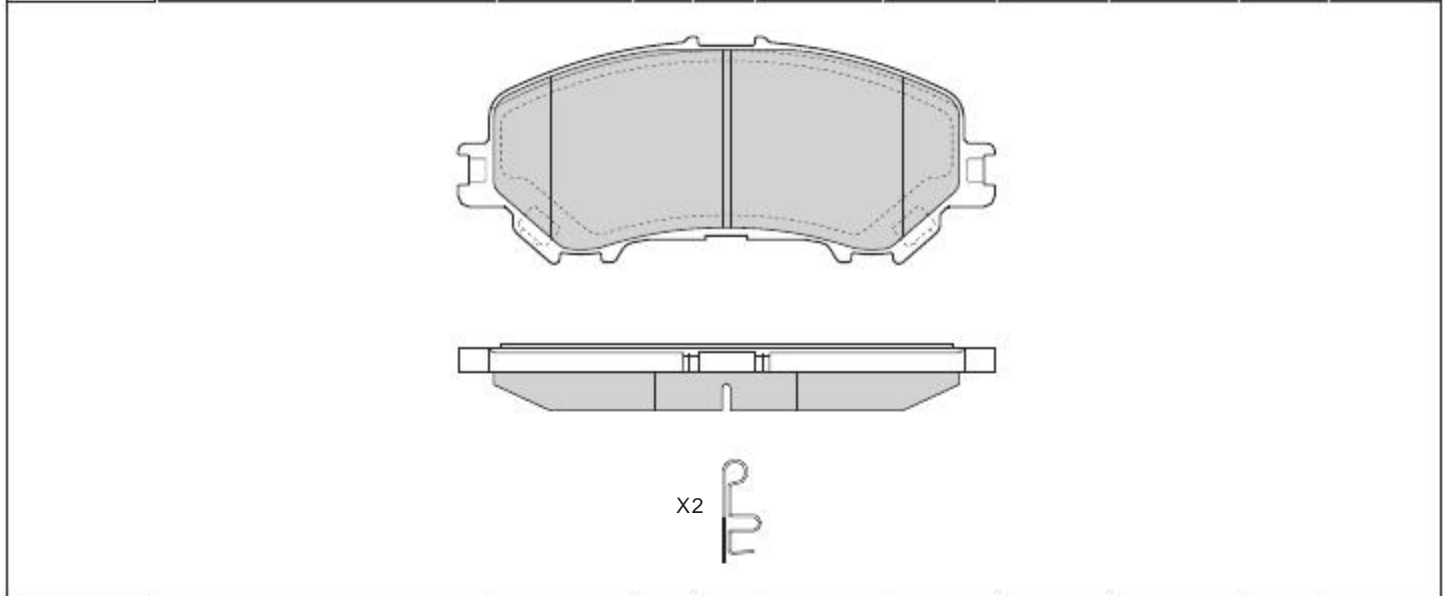



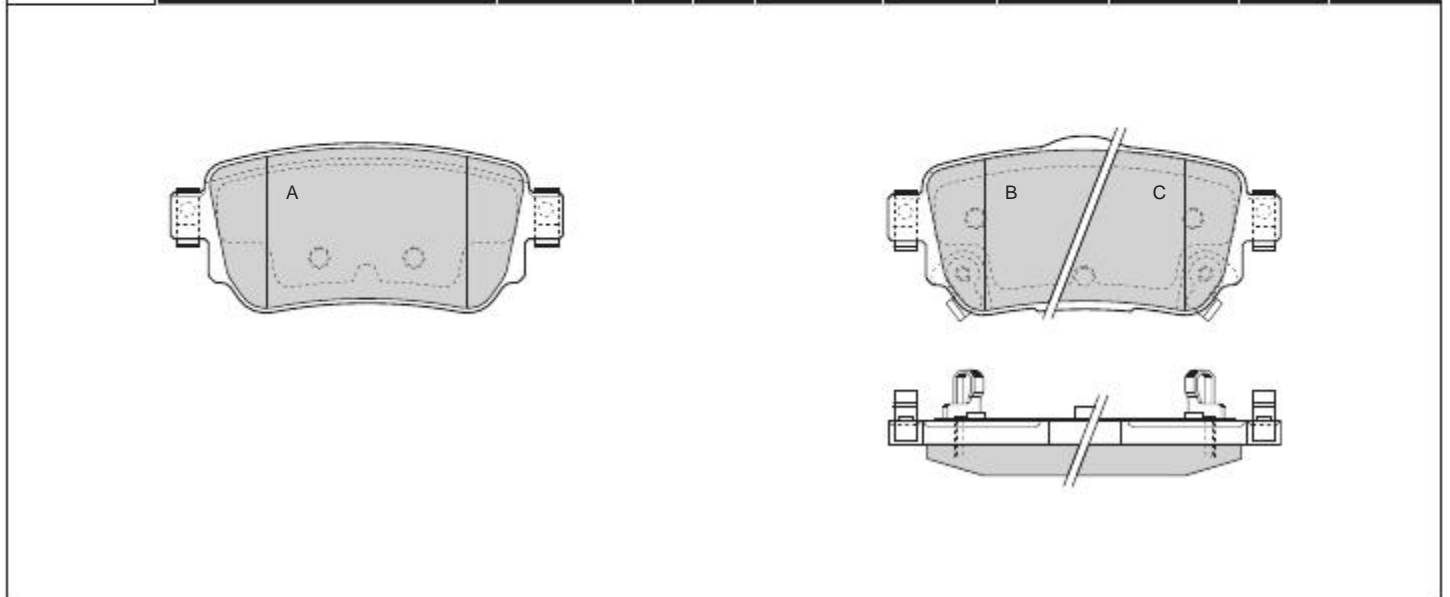

1588	NISSAN - RENAULT	AKEBONO	X	141,9	60	17,5	4		
------	------------------	---------	---	-------	----	------	---	--	--



1589	NISSAN - RENAULT	TRW	X	103,7	A 44,9 B-C 47,4	15,2	2A 1B-1C		
------	------------------	-----	---	-------	--------------------	------	-------------	--	--

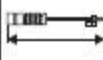

									
1590	FIAT - JEEP	TRW	X	115,4	49,5	17,5	2A-2B		

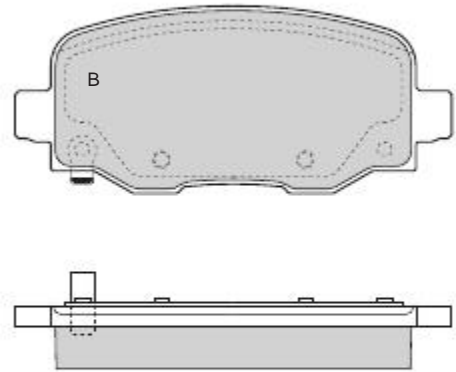
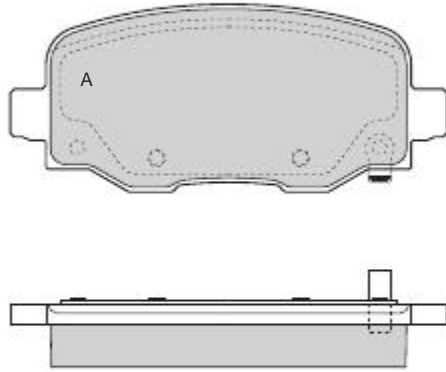



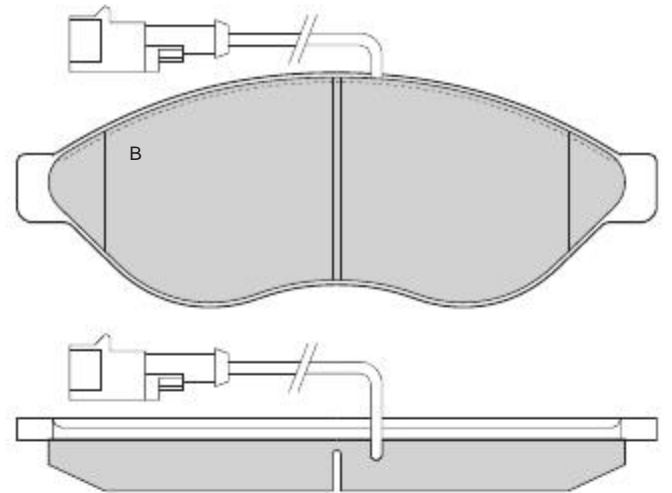
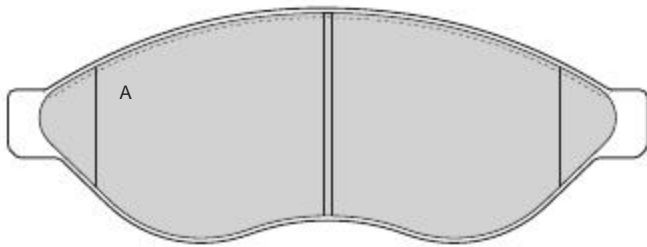



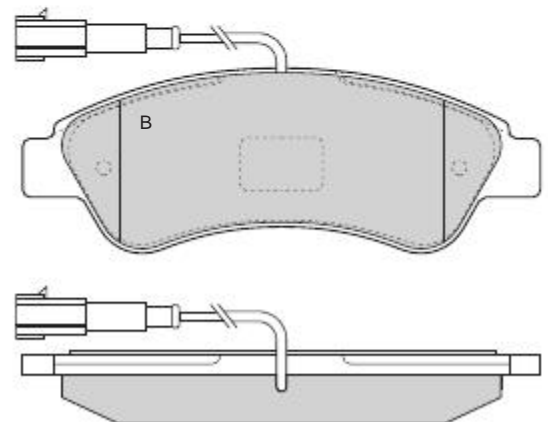
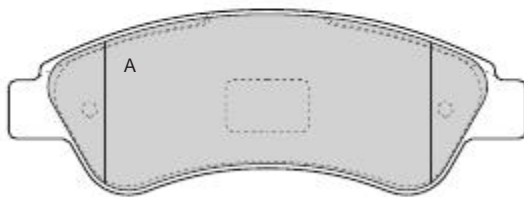



1591	CITROEN - FIAT - PEUGEOT	BREMBO	X	169,1	61,5	19,2	2A-2B	2	155
------	--------------------------	--------	---	-------	------	------	-------	---	-----



1592	FIAT	BOSCH	X	136,8	48,9	19,2	2A-2B	2	215
------	------	-------	---	-------	------	------	-------	---	-----



									
1593	RENAULT	TRW	X	131,2	62,4	17,6	3A-1B	1	235

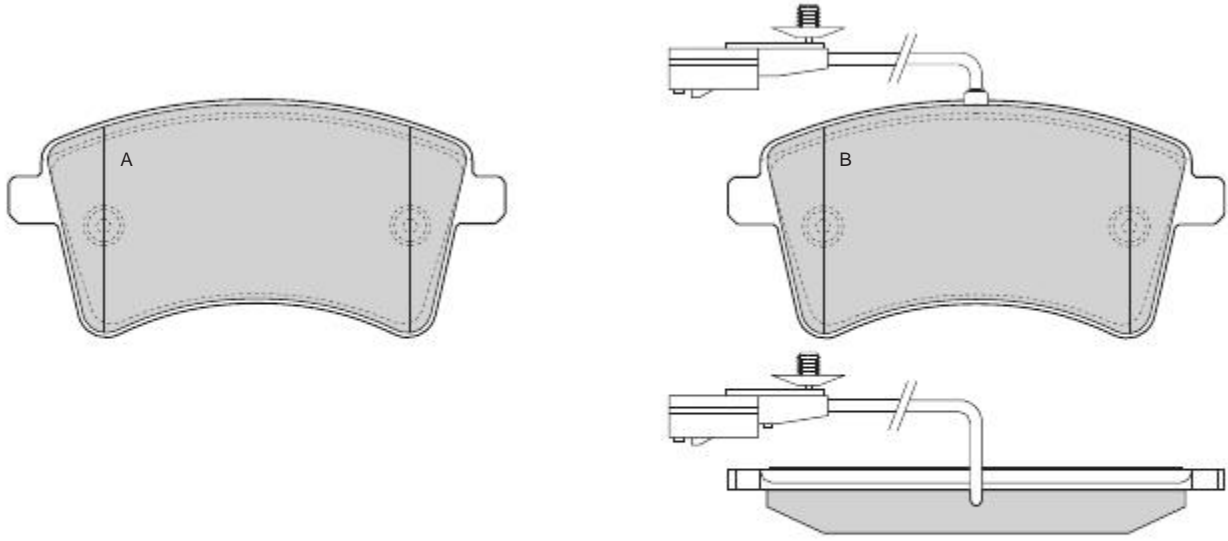



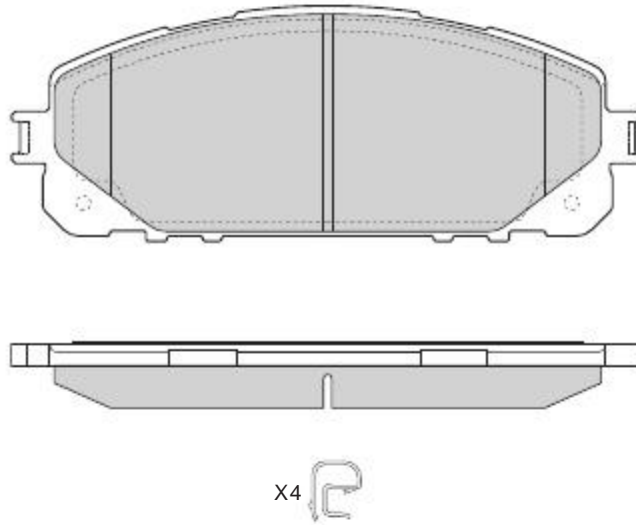



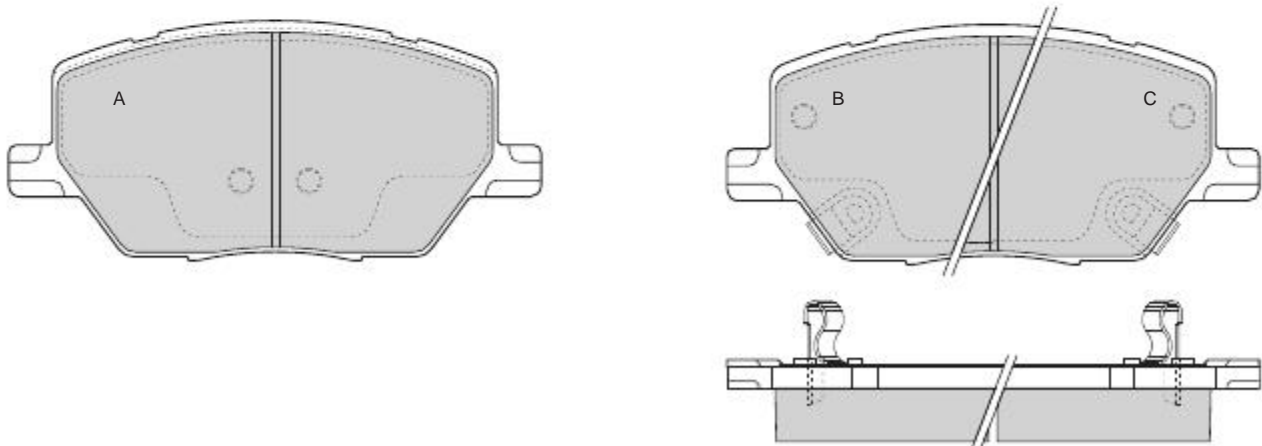



1594	JEEP	ADVICS	X	167	62,2	17,5	4		
------	------	--------	---	-----	------	------	---	--	--



1595	JEEP	TRW	X	140,7	63,3	20,4	2A 1B-1C		
------	------	-----	---	-------	------	------	-------------	--	--



									
1596	SUZUKI	AKEBONO	X	142	55	16,8	4		

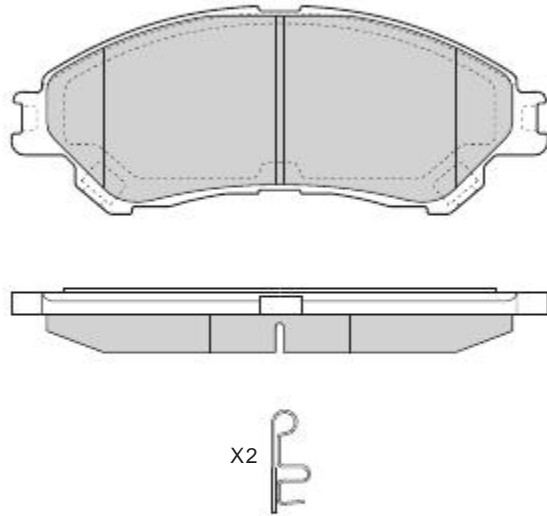



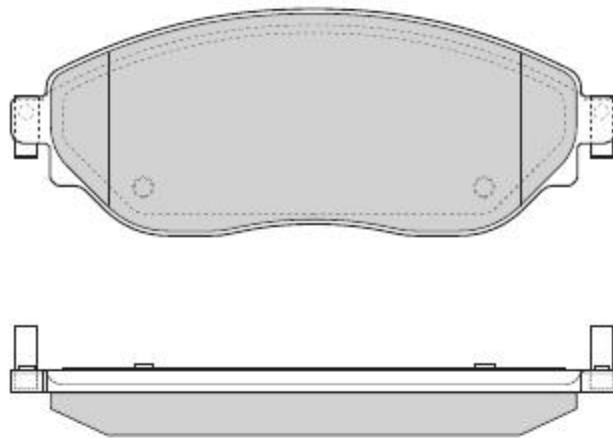



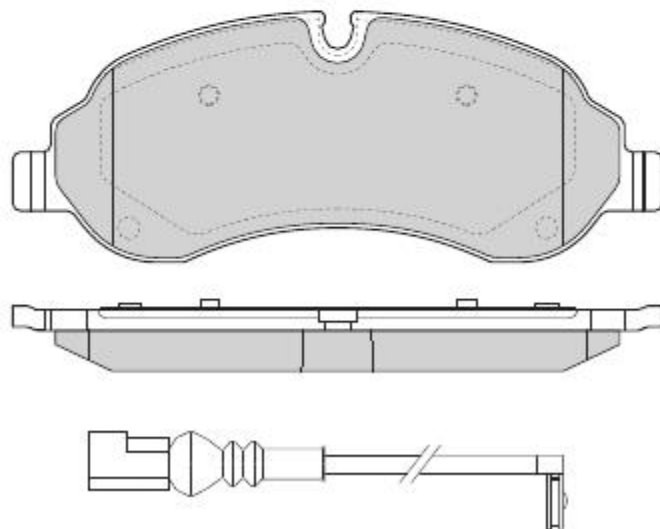

1597	OPEL - RENAULT	TRW	X	160	59,9	18	4		
------	----------------	-----	---	-----	------	----	---	--	--



1598	FORD	BOSCH	X	171,8	66,3	17	4	2	320
------	------	-------	---	-------	------	----	---	---	-----



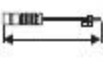

									
1599	FORD	TRW	X	137	A 55,8 B 58,3	17,7	2 A-2 B		

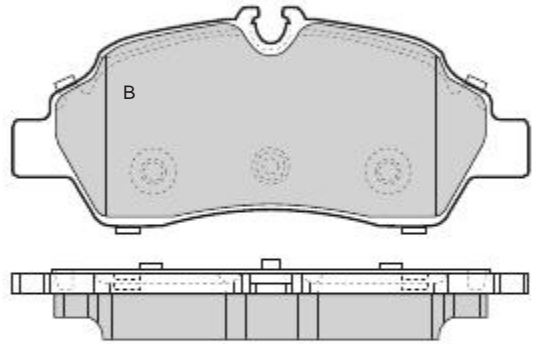
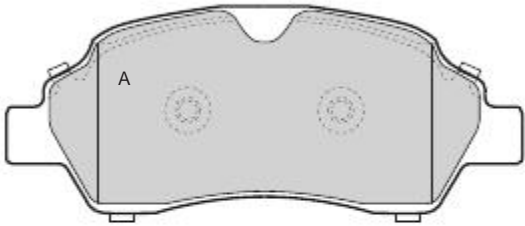

1600	ALFA ROMEO	BREMBO	X	131,8	77,3	16,8	1A-1B 1C-1D	2	155
------	------------	--------	---	-------	------	------	----------------	---	-----

